



SILENT KNIGHT

**Model SK-2/E & SK-4/E Fire Alarm
Control Panel**

**Installation and
Operations Manual**

**Part Number 52604 Rev. A
ECN 05-276 08/08/05**

Fire Alarm System Limitations

An automatic fire alarm system—typically made up of smoke detectors, heat detectors, manual pull stations, audible warning devices, and a fire alarm control panel with remote notification capability—can provide early warning of a developing fire. Such a system, however, does not assure protection against property damage or loss of life resulting from a fire. The Manufacturer recommends that smoke and/or heat detectors be located throughout a protected premise following the recommendations of the current edition of the National Fire Protection Association Standard 72 (NFPA 72), manufacturer's recommendations, State and local codes, and the recommendations contained in the Guide for Proper Use of System Smoke Detectors, which is made available at no charge to all installing dealers. A study by the Federal Emergency Management Agency (an agency of the United States government) indicated that smoke detectors may not go off in as many as 35% of all fires. While fire alarm systems are designed to provide early warning against fire, they do not guarantee warning or protection against fire. A fire alarm system may not provide timely or adequate warning, or simply may not function, for a variety of reasons:

Smoke detectors may not sense fire where smoke cannot reach the detectors such as in chimneys, in or behind walls, on roofs, or on the other side of closed doors. Smoke detectors also may not sense a fire on another level or floor of a building. A second-floor detector, for example, may not sense a first-floor or basement fire.

Particles of combustion or "smoke" from a developing fire may not reach the sensing chambers of smoke detectors because:

- Barriers such as closed or partially closed doors, walls, or chimneys may inhibit particle or smoke flow.
- Smoke particles may become "cold," stratify, and not reach the ceiling or upper walls where detectors are located.
- Smoke particles may be blown away from detectors by air outlets.
- Smoke particles may be drawn into air returns before reaching the detector.

The amount of "smoke" present may be insufficient to alarm smoke detectors. Smoke detectors are designed to alarm at various levels of smoke density. If such density levels are not created by a developing fire at the location of detectors, the detectors will not go into alarm.

Smoke detectors, even when working properly, have sensing limitations. Detectors that have photoelectronic sensing chambers tend to detect smoldering fires better than flaming fires, which have little visible smoke. Detectors that have ionizing-type sensing chambers tend to detect fast-flaming fires better than smoldering fires. Because fires develop in different ways and are often unpredictable in their growth, neither type of detector is necessarily best and a given type of detector may not provide adequate warning of a fire.

Smoke detectors cannot be expected to provide adequate warning of fires caused by arson, children playing with matches (especially in bedrooms), smoking in bed, and violent explosions (caused by escaping gas, improper storage of flammable materials, etc.).

While a fire alarm system may lower insurance rates, it is not a substitute for fire insurance!

Heat detectors do not sense particles of combustion and alarm only when heat on their sensors increases at a predetermined rate or reaches a predetermined level. Rate-of-rise heat detectors may be subject to reduced sensitivity over time. For this reason, the rate-of-rise feature of each detector should be tested at least once per year by a qualified fire protection specialist. *Heat detectors are designed to protect property, not life.*

IMPORTANT! Smoke detectors must be installed in the same room as the control panel and in rooms used by the system for the connection of alarm transmission wiring, communications, signaling, and/or power. If detectors are not so located, a developing fire may damage the alarm system, crippling its ability to report a fire.

Audible warning devices such as bells may not alert people if these devices are located on the other side of closed or partly open doors or are located on another floor of a building. Any warning device may fail to alert people with a disability or those who have recently consumed drugs, alcohol or medication. Please note that:

- Strobes can, under certain circumstances, cause seizures in people with conditions such as epilepsy.
- Studies have shown that certain people, even when they hear a fire alarm signal, do not respond or comprehend the meaning of the signal. It is the property owner's responsibility to conduct fire drills and other training exercise to make people aware of fire alarm signals and instruct them on the proper reaction to alarm signals.
- In rare instances, the sounding of a warning device can cause temporary or permanent hearing loss.

A fire alarm system will not operate without any electrical power. If AC power fails, the system will operate from standby batteries only for a specified time and only if the batteries have been properly maintained and replaced regularly.

Equipment used in the system may not be technically compatible with the control. It is essential to use only equipment listed for service with your control panel.

Telephone lines needed to transmit alarm signals from a premise to a central monitoring station may be out of service or temporarily disabled. For added protection against telephone line failure, backup radio transmission systems are recommended.

The most common cause of fire alarm malfunction is inadequate maintenance. To keep the entire fire alarm system in excellent working order, ongoing maintenance is required per the manufacturer's recommendations, and UL and NFPA standards. At a minimum, the requirements of NFPA 72 shall be followed. Environments with large amounts of dust, dirt or high air velocity require more frequent maintenance. A maintenance agreement should be arranged through the local manufacturer's representative. Maintenance should be scheduled monthly or as required by National and/or local fire codes and should be performed by authorized professional fire alarm installers only. Adequate written records of all inspections should be kept.

Installation Precautions

WARNING - Several different sources of power can be connected to the fire alarm control panel. Disconnect all sources of power before servicing. Control unit and associated equipment may be damaged by removing and/or inserting cards, modules, or interconnecting cables while the unit is energized. Do not attempt to install, service, or operate this unit until this manual is read and understood.

CAUTION - *System Reacceptance Test after Software Changes.* To ensure proper system operation, this product must be tested in accordance with NFPA 72 after any programming operation or change in site-specific software. Reacceptance testing is required after any change, addition or deletion of system components, or after any modification, repair or adjustment to system hardware or wiring.

All components, circuits, system operations, or software functions known to be affected by a change must be 100% tested. In addition, to ensure that other operations are not inadvertently affected, at least 10% of initiating devices that are not directly affected by the change, up to a maximum of 50 devices, must also be tested and proper system operation verified.

This system meets NFPA requirements for indoor dry operation at 0-49° C/32-120° F and at a relative humidity of 93 ±2% RH (non-condensing) at 32 ±2° C/90 ±3° F. However, the useful life of the system's standby batteries and the electronic components may be adversely affected by extreme temperature ranges and humidity. Therefore, it is recommended that this system and all peripherals be installed in an environment with a nominal room temperature of 15-27° C/60-80° F.

Verify that wire sizes are adequate for all initiating and indicating device loops. Refer to manual Specifications section for maximum allowable I.R. drop from the specified device voltage.

Adherence to the following will aid in problem-free installation with long-term reliability:

Like all solid state electronic devices, this system may operate erratically or can be damaged when subjected to lightning-induced transients. Although no system is completely immune from lightning transients and interferences, proper grounding will reduce susceptibility. *Overhead or outside aerial wiring is not recommended, due to an increased susceptibility to nearby lightning strikes.* Consult with the Technical Services Department if any problems are anticipated or encountered.

Disconnect AC power and batteries prior to removing or inserting circuit boards. Failure to do so can damage circuits.

Remove all electronic assemblies prior to any drilling, filing, reaming, or punching of the enclosure. When possible, make all cable entries from the sides or rear. Before making modifications, verify that they will not interfere with battery, transformer, and printed circuit board location.

Do not tighten screw terminals more than 9 in-lbs. Over-tightening may damage threads, resulting in reduced terminal contact pressure and difficulty with screw terminal removal.

This system contains static-sensitive components. Always ground yourself with a proper wrist strap before handling any circuits so that static charges are removed from the body. Use static-suppressive packaging to protect electronic assemblies removed from the unit.

Follow the instructions in the installation, operating, and programming manuals. These instructions must be followed to avoid damage to the control panel and associated equipment. FACP operation and reliability depend upon proper installation by authorized personnel.

FCC Warning

WARNING: This equipment generates, uses, and can radiate radio frequency energy and if not installed and used in accordance with the instruction manual, may cause interference to radio communications. It has been tested and found to comply with the limits for class A computing device pursuant to Subpart B of Part 15 of FCC Rules, which is designed to provide reasonable protection against such interference when operated in a commercial environment. Operation of this equipment in a residential area is likely to cause interference, in which case the user will be required to correct the interference at their own expense.

Canadian Requirements

This digital apparatus does not exceed the Class A limits for radiation noise emissions from digital apparatus set out in the Radio Interference Regulations of the Canadian Department of Communications.

Le présent appareil numérique n'émet pas de bruits radioélectriques dépassant les limites applicables aux appareils numériques de la classe A prescrites dans le Règlement sur le brouillage radioélectrique édicté par le ministère des Communications du Canada.

Notes

Table of Contents

SECTION 1: Product Description	10
1.1: Product Features	10
1.2: Specifications	12
1.3: Controls and Indicators	13
1.4: Circuits	14
1.5: Components	14
1.6: Optional Modules and Accessories	15
SECTION 2: Installation	17
2.1: Backbox Mounting	17
2.2: Operating Power	19
2.3: Input Circuits	20
2.4: Output Circuits	22
2.4.1: Notification Appliance Circuits	22
2.4.2: Special Application DC Power Output Connections	23
2.4.3: Relays	23
2.5: Power-limited Wiring Requirements	24
2.6: Installation of Optional Modules	25
2.6.1: SK-CAC4 Class A Converter Module (SK-4 only)	25
2.6.1.1 Installation	25
2.6.1.2 Wiring NACs and IDCs for Class A	26
2.6.2: SK-4XTM, SK-4XLM and SK-4XZM Option Modules	27
2.6.2.1 SK-4XTM Transmitter Module Installation	28
2.6.2.2 SK-4XZM Zone Relay Module (SK-4 only)	29
2.6.2.3 SK-4XLM LED Interface Module (SK-4 only)	30
SECTION 3: Program Options via DIP Switch	31
3.1: DIP Switch Settings	32
3.1.1: SW1 DIP Switch Settings	34
3.1.1.1 Silence Inhibit	34
3.1.1.2 Auto-silence	34
3.1.1.3 Temporal Coding	34
3.1.1.4 Selective Silence	34
3.1.1.5 Trouble Reminder	34
3.1.1.6 AC Trouble Delay	34
3.1.1.7 Autoresettable Supervisory	34
3.1.1.8 IDC Combination Circuit	34
3.1.2: SW2 DIP Switch Settings	35
3.1.2.1 IDC1 Verification (SK-4 only)	35
3.1.2.2 IDC1 Supervisory (SK-4 only)	35
3.1.2.3 IDC1 Verification for SK-2 or IDC2 Verification for SK-4	35
3.1.2.4 IDC1 Supervisory for SK-2 or IDC2 Supervisory for SK-4	35
3.1.2.5 IDC2 Verification for SK-2 or IDC3 Verification for SK-4	36
3.1.2.6 IDC2 Supervisory for SK-2 or IDC3 Supervisory for SK-4	36
3.1.2.7 IDC4 Verification (SK-4 only)	36
3.1.2.8 IDC4 Supervisory (SK-4 only)	36
3.1.3: SW3 DIP Switch Settings	36
3.1.3.1 NAC1 Nonsilenceable	36
3.1.3.2 NAC1 Disable	36
3.1.3.3 NAC2 Nonsilenceable (SK-4 only)	36
3.1.3.4 NAC2 Disable (SK-4 only)	36
3.1.3.5 Strobe Synchronization	37
3.1.3.5.1 Maximum Number of Strobes for Synchronization	37
3.1.3.6 Nonsilenceable Waterflow for Combination Circuit	37
3.1.3.7 Spares	37

SECTION 4: Operating Instructions38

- 4.1: Switch Functions in Normal Mode.....38
 - 4.1.1: ACK - Acknowledge38
 - 4.1.2: Silence38
 - 4.1.3: Zone Enable/Disable38
 - 4.1.4: Reset/(Lamp Test)38
 - 4.1.5: Walktest39
- 4.2: Walktest39
- 4.3: Status LEDs40
- 4.4: Operation41
 - 4.4.1: Fire Alarm Response42
 - 4.4.2: Fire Alarm Restoral42
 - 4.4.3: System Supervisory Condition Response42
 - 4.4.4: System Supervisory Restoral Response42
 - 4.4.5: Trouble Condition Response43
 - 4.4.6: Trouble Condition Restoral43

SECTION 5: Power Supply Calculations44

- 5.1: Overview44
- 5.2: Calculating the AC Branch Circuit.....44
- 5.3: Calculating the System Current Draw45
 - 5.3.1: Overview45
 - 5.3.2: How to Use Table 5-3 on page 46 to Calculate System Current Draw45
- 5.4: Calculating the Battery Size47
 - 5.4.1: NFPA Battery Requirements47
 - 5.4.2: Selecting and Locating Batteries47

It is imperative that the installer understand the requirements of the Authority Having Jurisdiction (AHJ) and be familiar with the standards set forth by the following regulatory agencies:

- Underwriters Laboratories Standards
- NFPA 72 National Fire Alarm Code

Before proceeding, the installer should be familiar with the following documents.



NFPA Standards

This Fire Alarm Control Panel complies with the following NFPA Standards:

NFPA 72 National Fire Alarm Code for Local Fire Alarm Systems and Remote Station Fire Alarm Systems (requires an optional Remote Station Output Module)



Underwriters Laboratories Documents for Reference:

- UL 38 Manually Actuated Signaling Boxes
- UL 217 Smoke Detectors, Single and Multiple Station
- UL 228 Door Closers–Holders for Fire Protective Signaling Systems
- UL 268 Smoke Detectors for Fire Protective Signaling Systems
- UL 268A Smoke Detectors for Duct Applications
- UL 346 Waterflow Indicators for Fire Protective Signaling Systems
- UL 464 Audible Signaling Appliances
- UL 521 Heat Detectors for Fire Protective Signaling Systems
- UL 864 Standard for Control Units for Fire Protective Signaling Systems
- UL 1481 Power Supplies for Fire Protective Signaling Systems
- UL 1638 Visual Signaling Appliances
- UL 1971 Signaling Devices for Hearing Impaired

Other:

- NEC Article 250 Grounding
- NEC Article 300 Wiring Methods
- NEC Article 760 Fire Protective Signaling Systems
- Applicable Local and State Building Codes
- Requirements of the Local Authority Having Jurisdiction (LAHJ)

SilentKnight Documents

SilentKnight Device Compatibility Document Document #52612

This product has been certified to comply with the requirements in the Standard for Control Units and Accessories for Fire Alarm Systems, UL 864, 9th Edition. Operation of this product with products not tested for UL 864, 9th Edition has not been evaluated. Such operation requires the approval of the local Authority Having Jurisdiction (AHJ).

Two Zone Main Circuit Board

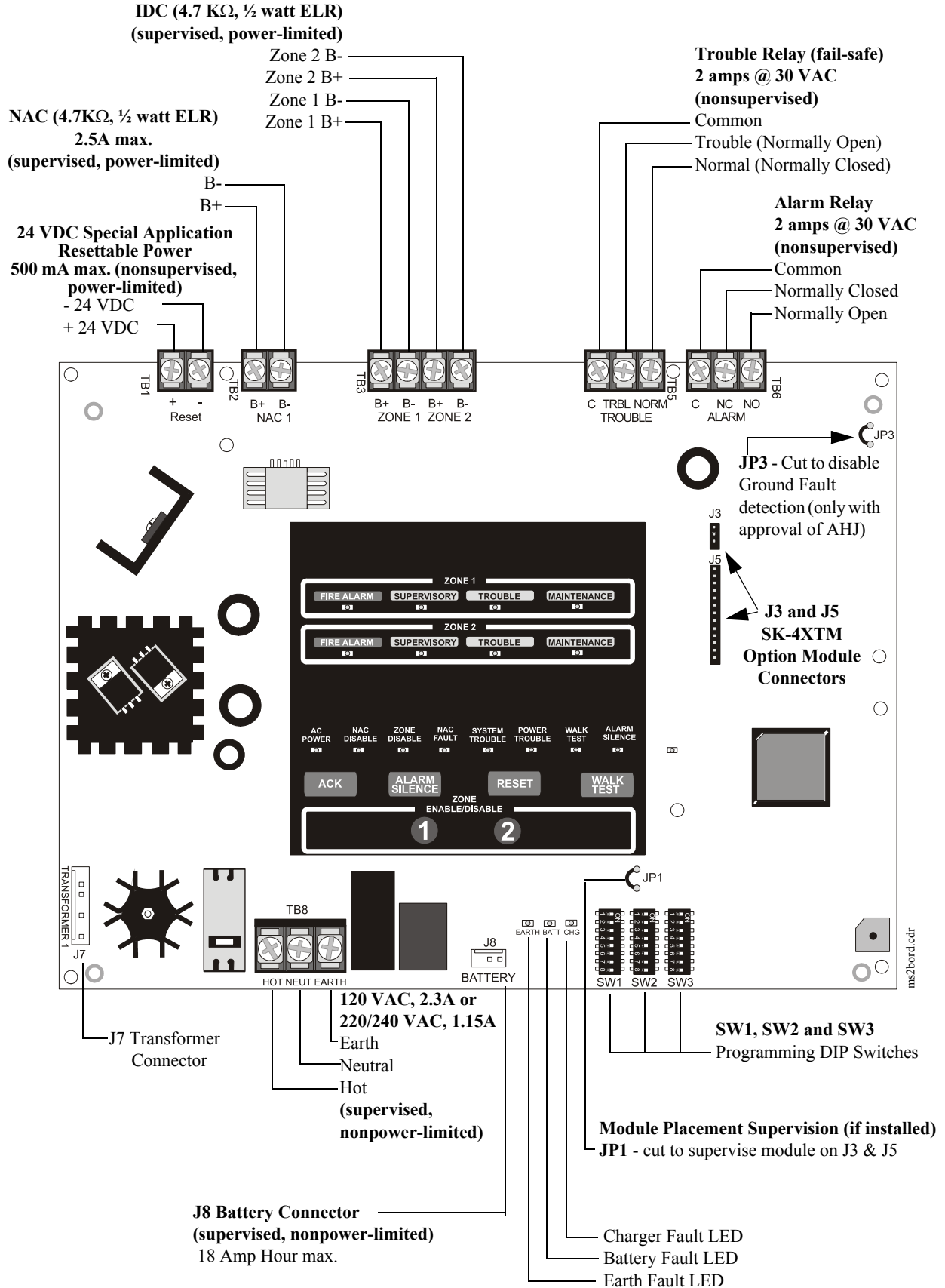

4 Zone Main Circuit Board

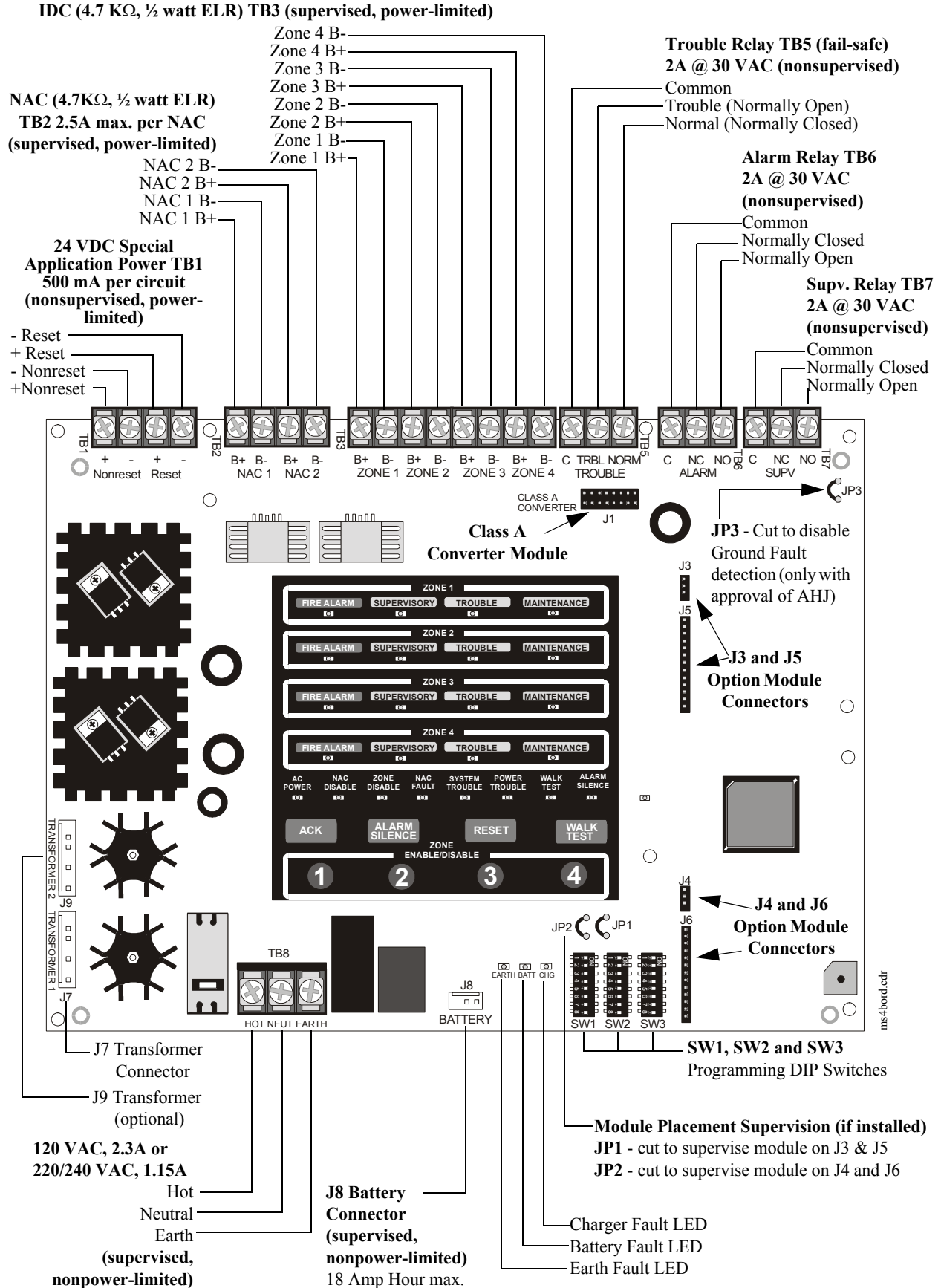

SECTION 1 Product Description

The SK-2 is a two zone FACP (Fire Alarm Control Panel) and the SK-4 is a four zone FACP. The information in this manual refers to both the SK-2 and SK-4 unless otherwise specified. These control panels provide reliable fire signaling protection for small to medium sized commercial, industrial and institutional buildings. The FACP is compatible with System Sensor's I³ detectors which are microprocessor-based conventional smoke detectors that can transmit a maintenance trouble signal to the FACP indicating the need for cleaning and a supervisory 'freeze' signal when the ambient temperature falls below the detector rating (refer to System Sensor's I³ Installation and Maintenance Instructions document I56-1800-00 for device specifications). In addition, the control panel is compatible with conventional input devices such as two-wire smoke detectors, four-wire smoke detectors, pull stations, waterflow devices, tamper switches and other normally-open contact devices. Refer to SilentKnight Device Compatibility Document for a complete listing of compatible devices.

Outputs include one NAC (Notification Appliance Circuit) on the SK-2 and two NACs on the SK-4. Each FACP has a Form-C Alarm and Trouble relay and 24 VDC special application resettable power. In addition, the SK-4 has a Form-C Supervisory relay and a nonresettable special application power output. The FACP supervises wiring, AC voltage and battery level.

Activation of a compatible smoke detector or any normally-open fire alarm initiating device will activate audible and visual signaling devices, illuminate an indicating LED, sound the piezo sounder at the FACP, activate the FACP alarm relay and operate an optional module used to notify a remote station or initiate a auxiliary control function. The SK-2E and SK-4E offer the same features as the SK-2 and SK-4 but allows connection to 220/240 VAC.

Note: Unless otherwise specified, the terms SK-2 and SK-4 are used in this manual to refer to the SK-2 and SK-2E as well as the SK-4 and SK-4E FACP's respectively.

1.1 Product Features

- Style B (Class B) IDC (Initiating Device Circuit)
 - ✓ one zone programmable for combination supervisory and waterflow
 - ✓ SK-2 - two IDCs
 - ✓ SK-4 - four IDCs
- Style Y (Class B) NAC (Notification Appliance Circuit)
 - ✓ SK-2- one NAC
 - ✓ SK-4 - two NACs
- Form-C Alarm Relay
- Form-C Trouble Relay
- Form-C Supervisory Relay (SK-4 only)
- 3.0 amps total system current standard for SK-2 and SK-4
- 6.0 amps total system current available for SK-4 with optional second transformer
- Dress Panel SK-DP2/4
- Optional Trim Ring P/N: TR-1-R for semi-flush mounting the cabinet

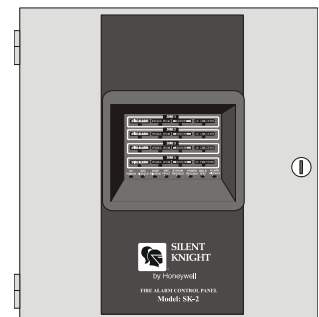

- Control Buttons
 - ✓ ACK (Acknowledge)
 - ✓ Alarm Silence
 - ✓ Reset
 - ✓ Walktest
 - ✓ Zone Enable/Disable (one per zone)
- LED Indicators
 - ✓ Fire Alarm (one per zone)
 - ✓ Supervisory (one per zone)
 - ✓ Trouble (one per zone)
 - ✓ Maintenance (one per zone)
 - ✓ AC Power
 - ✓ NAC Disable
 - ✓ Zone Disable
 - ✓ NAC Fault
 - ✓ System Trouble
 - ✓ Power Trouble
 - ✓ Walktest
 - ✓ Alarm Silence
 - ✓ Earth Fault LED (on circuit board) lights if zero impedance between FACP and ground exist
 - ✓ Battery Fault (on circuit board)
 - ✓ Charger Fault (on circuit board)
- Piezo sounder for alarm, trouble and supervisory
- 24 volt operation
- Low AC voltage sense
- Alarm Verification
- NACs Programmable for:
 - ✓ Silence Inhibit
 - ✓ Auto-Silence
 - ✓ Strobe Synchronization
 - ✓ Selective Silence (horn-strobe mute)
 - ✓ Temporal or Steady Signal
 - ✓ Silenceable or Nonsilenceable
- Automatic battery trickle charger
- Silent or audible walktest capabilities
- Optional NAC Class A converter module (SK-4 only)
- Optional SK-4XTM Transmitter Module (SK-2 and SK-4)
- Optional SK-4XZM Zone Relay Module (SK-4 only)
- Optional SK-4XLM Module for SK-RZA4 Remote LED Annunciator (SK-4 only)

1.2 Specifications

AC Power - TB8

SK-2/SK-4: 120 VAC, 50/60 Hz, 2.3 amps

SK-2E/SK-4E: 240 VAC, 50 Hz, 1.15 amps

Wire size: minimum #14 AWG (2.0 mm²) with 600V insulation

Battery (sealed lead acid only) - J8

Maximum Charging Circuit - Normal Flat Charge: 27.6 VDC @ 0.8 amp

Maximum Charger Capacity: 18 Amp Hour battery (two 7 Amp Hour batteries can be housed in the FACP cabinet. Larger batteries require a separate battery box such as the RBB)

Initiating Device Circuits - TB3

Alarm Zones 1 & 2 (SK-2 and SK-4)

Alarm Zones 3 & 4 (SK-4 only)

Power-limited circuitry

Operation: All zones Style B (Class B)

Normal Operating Voltage: Nominal 20 VDC, Maximum 27 VDC

Alarm Current: 15 mA minimum

Short Circuit Current: 40 mA maximum

Maximum Loop Resistance: 100 ohms

End-of-Line Resistor: 4.7K Ω , 1/2 watt (Part #71252)

Standby Current: 4 mA

Refer to SilentKnight Device Compatibility Document for listed compatible devices

Notification Appliance Circuit(s) - TB2¹

One NAC on SK-2, two NACs on SK-4

Operation: Style Y (Class B)

Power-limited Circuitry

Normal Operating Voltage: Nominal 24 VDC, Maximum 27 VDC

Maximum Signaling Current: 2.5 amps total with standard transformer. 5.0 amps total (2.5 amp maximum per NAC) with optional transformer on SK-4 only

Maximum Line Impedance: 1.5 volt drop end-of-line

End-of-Line Resistor: 4.7K Ω , 1/2 watt (Part #71252)

Refer to SilentKnight Device Compatibility Document for compatible listed devices

Form-C Relays

Trouble Relay TB5 (fail-safe)

Alarm Relay TB6

Supervisory Relay TB7 (SK-4 only)

Relay Contact Ratings: 2 amps @ 30 VAC (resistive)

Resettable Special Application Power - TB1

Operating Voltage: Nominal 24 VDC

Maximum Available Current: 500 mA - appropriate for powering 4-wire smoke detectors (see note 1)

Power-limited Circuitry

Refer to SilentKnight Device Compatibility Document for compatible listed devices

Nonresettable Special Application Power - TB1 (SK-4 only)

Operating Voltage: Nominal 24 VDC

Maximum Available Current: 500 mA (see note 1)

Power-limited Circuitry

Refer to SilentKnight Device Compatibility Document for compatible listed devices

-
1. Total current for resettable power and one Notification Appliance Circuit must not exceed 3.0 amps for the SK-2. Total current for nonresettable power, resettable power and two Notification Appliance Circuits must not exceed 6.0 amps for the SK-4 (requires optional second transformer)

1.3 Controls and Indicators

Front Panel Membrane Buttons

- Acknowledge
- Alarm Silence
- Reset
- Walktest
- Zone Enable/Disable - Zone 1
- Zone Enable/Disable - Zone 2
- Zone Enable/Disable - Zone 3 (SK-4 only)
- Zone Enable/Disable - Zone 4 (SK-4 only)

LED Indicators

- Fire Alarm Zone 1 - red LED
- Fire Alarm Zone 2 - red LED
- Fire Alarm Zone 3 - red LED (SK-4 only)
- Fire Alarm Zone 4 - red LED (SK-4 only)
- Supervisory Zone 1 - yellow LED
- Supervisory Zone 2 - yellow LED
- Supervisory Zone 3 - yellow LED (SK-4 only)
- Supervisory Zone 4 - yellow LED (SK-4 only)
- Trouble Zone 1 - yellow LED
- Trouble Zone 2 - yellow LED
- Trouble Zone 3 - yellow LED (SK-4 only)
- Trouble Zone 4 - yellow LED (SK-4 only)
- Maintenance Zone 1 - yellow LED
- Maintenance Zone 2 - yellow LED
- Maintenance Zone 3 - yellow LED (SK-4 only)
- Maintenance Zone 4 - yellow LED (SK-4 only)
- AC Power - green LED
- NAC Disable - yellow LED
- Zone Disable - yellow LED
- NAC Fault - yellow LED
- System Trouble - yellow LED
- Power Trouble - yellow LED
- Walktest - yellow LED
- Alarm Silence - yellow LED
- Earth Fault - yellow LED (on main circuit board) lights if zero impedance between FACP and ground exists
- Battery Fault - yellow LED (on main circuit board)
- Charger Fault - yellow LED (on main circuit board)

Local Piezo Sounder

A piezo sounder provides separate and distinct sounds for alarm, trouble, maintenance and supervisory conditions as follows:

- Alarm - on steady
- Trouble - pulse 1 second on and 1 second off
- Maintenance - pulse ½ second on and ½ second off
- Supervisory - pulse ½ second on and ½ second off

1.4 Circuits

Input Circuits

Two input IDCs (Initiating Device Circuits) on the SK-2 and four IDCs on the SK-4 provide Style B (Class B) configurations. All IDCs accept I³ detectors as well as conventional two-wire smoke detectors, four-wire smoke detectors and normally-open contact devices.

Output Circuits

- 24 VDC resettable special application power output - 500 mA
- 24 VDC nonresettable special application power output (SK-4 only) - 500 mA
- 24 volt battery charger (up to 18 Amp Hour batteries)

Notification Appliance Circuits

One NAC (Notification Appliance Circuit) Style Y (Class B) on the SK-2
Two NACs Style Y (Class B) on the SK-4

Relays

Alarm Relay
Trouble Relay (fail-safe)
Supervisory Relay (SK-4 only)
Form-C contacts rated 2.0 amps @ 30 VAC (resistive)

1.5 Components

Main Circuit Board

The main circuit board contains the system's CPU, power supply, other primary components and wiring interface connectors. Optional modules plug in and are mounted to the main circuit board.

Cabinet

The backbox measures 14.5" (36.8 cm) x 15.218" (38.65 cm) x 2.875" (7.3 cm) and provides space for two batteries (up to 7 Amp Hours). Also included is a dress panel which mounts inside the cabinet.

Transformer Assembly

One 100VA transformer is provided standard with the FACP. An optional second 100VA transformer is available for the SK-4 to provide maximum accessory power.

Batteries

The cabinet provides space for two 7 Amp Hour batteries (larger batteries up to 18 Amp Hour, require use of a UL listed battery box such as the RBB). Batteries must be ordered separately.

1.6 Optional Modules and Accessories

SK-CAC4 Class A Converter Module (SK-4 only)

The SK-CAC4 Module can be used to convert the Style B (Class B) Initiating Device Circuits to Style D (Class A) and Style Y (Class B) Notification Appliance Circuits to Style Z (Class A). The module connects to J1 on the SK-4 main circuit board.

SK-4XTM Transmitter Module (SK-2 and SK-4)

The SK-4XTM provides a supervised output for local energy municipal box transmitter and alarm and trouble reverse polarity. It includes a disable switch and disable trouble LED. A module jumper option allows the reverse polarity circuit to open with a system trouble condition if no alarm condition exists. The SK-4XTM mounts to the SK-2 main circuit board option module connectors J3 & J5 or the SK-4 main circuit board, occupying one of the two sets of option module connectors J3 & J5 or J4 & J6.

SK-4XLM LED Interface Module (SK-4 only)

The LED Interface Module supports the SK-RZA4 Remote Annunciator module. Annunciator wiring is supervised for open conditions by this module. The SK-4XLM mounts to the SK-4 main circuit board option module connectors J3 and J5 only.

SK-RZA4 Remote Annunciator (SK-4 only)

The Remote Annunciator mounts on a standard single-gang electrical box and provides LED indication of the following:

- Alarm Zone 1 (red LED)
- Alarm Zone 2 (red LED)
- Alarm Zone 3 (red LED)
- Alarm Zone 4 (red LED)
- System Trouble (yellow LED)

A Local Trouble Sounder and Silence Switch are also provided. All LED wiring is supervised for open conditions. Any open condition will cause the System Trouble LED to illuminate. Slide-in paper labels permit an easy change of zone information. *Note: The SK-RZA4 Remote Annunciator requires the use of the LED Interface Module (SK-4XLM).*

SK-4XZM Zone Relay Module (SK-4 only)

The Zone Relay Module provides Form-C relay contacts for the following:

- Alarm Zone 1
- Alarm Zone 2
- Alarm Zone 3
- Alarm Zone 4
- System Alarm
- System Trouble

As a jumper option, the first four relays described above can be made silenceable. The SK-4XZM mounts to the SK-4 main circuit board, occupying one of the two sets of option module connectors.

Dress Panel SK-DP2/4

A dress panel SK-DP2/4 is included. The dress panel restricts access to the system wiring while allowing access to the membrane switch panel.

Battery Box

The RBB battery box may be used to house two batteries greater than 7 Amp Hour to a maximum of 18 Amp Hour. The battery box mounts directly below the control panel cabinet, centered to the main circuit board. The RBB is red and is provided with knockouts.

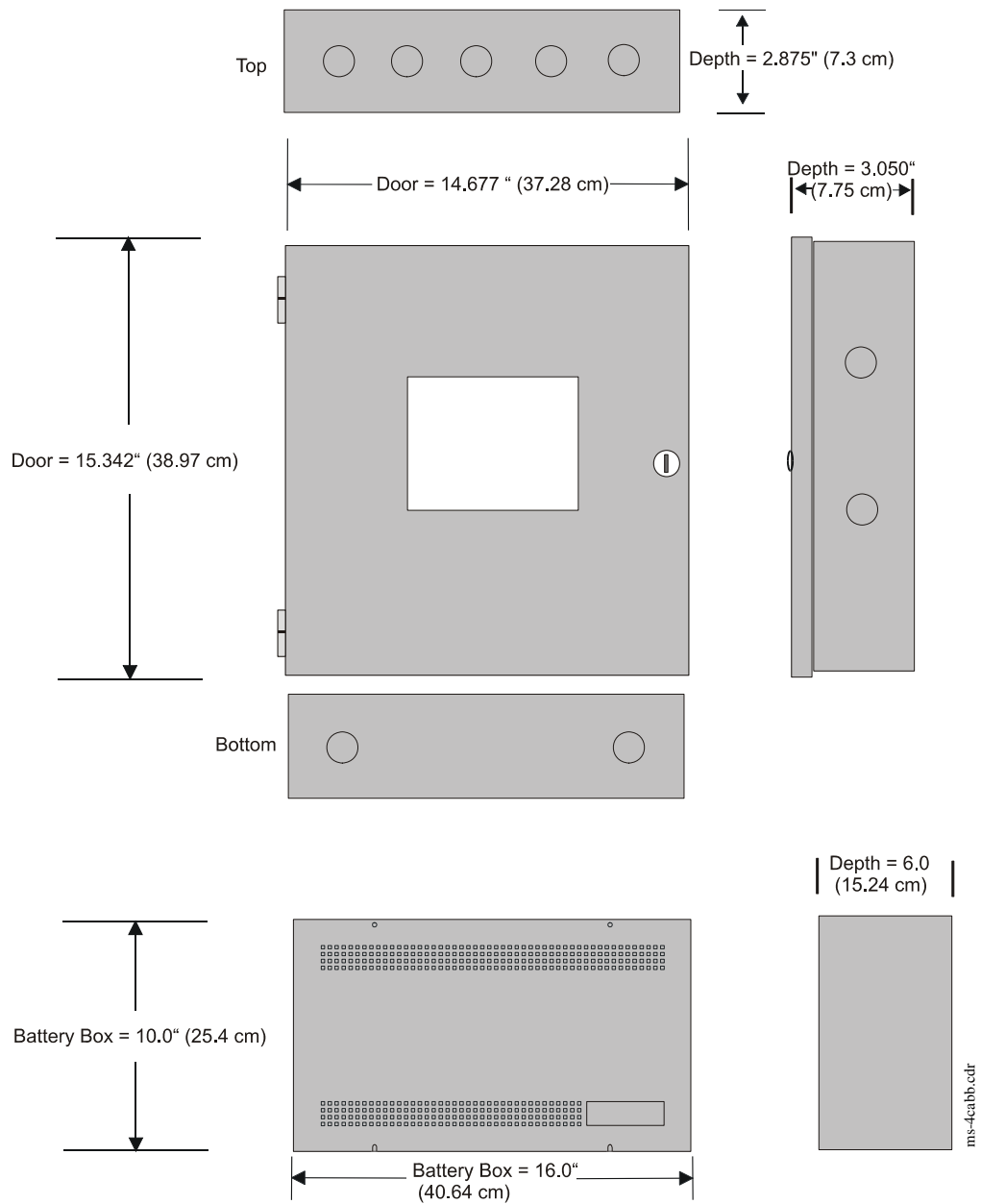

Figure 2.2 Backbox and Battery Box

When batteries larger than 7 Amp Hour, up to 18 Amp Hour, are being used, the RBB battery box (or UL listed equivalent) must be installed. To install the RBB:

1. Mount the FACP cabinet to the wall
2. Remove knockouts on the bottom of the FACP cabinet and top of the RBB
3. Using conduit, hang the RBB from the FACP cabinet making sure there is at least 1/2" of clearance between the two cabinets
4. Anchor the RBB to the wall

2.2 Operating Power



WARNING: Several different sources of power can be connected to this panel. Disconnect all sources of power before servicing. The panel and associated equipment may be damaged by removing and/or inserting cards, modules or interconnecting cables while this unit is energized.

Primary Power Source (AC) and Earth Ground Connections

AC power connections are made inside the control panel cabinet. The primary power source for the panel is 120 VAC, 50/60 Hz, 2.3 amps for the SK-2/SK-4 or 240 VAC, 50 HZ, 1.15 amps for the SK-2E/SK-4E. Run a pair of wires (with ground conductor) from the protected premises main breaker box to TB8 of the main circuit board. As per the National Electrical Code, use 14 AWG (2.00 mm², 1.6 mm O.D.) or heavier gauge wire with 600V insulation. No other equipment may be connected to this circuit. In addition, this circuit must be provided with overcurrent protection and may not contain any power disconnect devices. A separate Earth Ground connection must be made to ensure proper panel operation and lightning and transient protection. Connect the Earth Ground wire [minimum 14 AWG (2.00 mm²)] to the transformer mounting stud. *Do not use conduit for the Earth Ground connection since this does not provide reliable protection.*

Secondary Power Source (Batteries)

Observe polarity when connecting the battery. Connect the battery cable to J8 on the main circuit board using the plug-in connector and cable provided. The battery charger is current-limited and capable of charging sealed lead acid batteries. The charger shuts off when the system is in alarm.



WARNING: Battery contains sulfuric acid which can cause severe burns to the skin and eyes and can destroy fabrics. If contact is made with sulfuric acid, immediately flush the skin or eyes with water for 15 minutes and seek immediate medical attention.

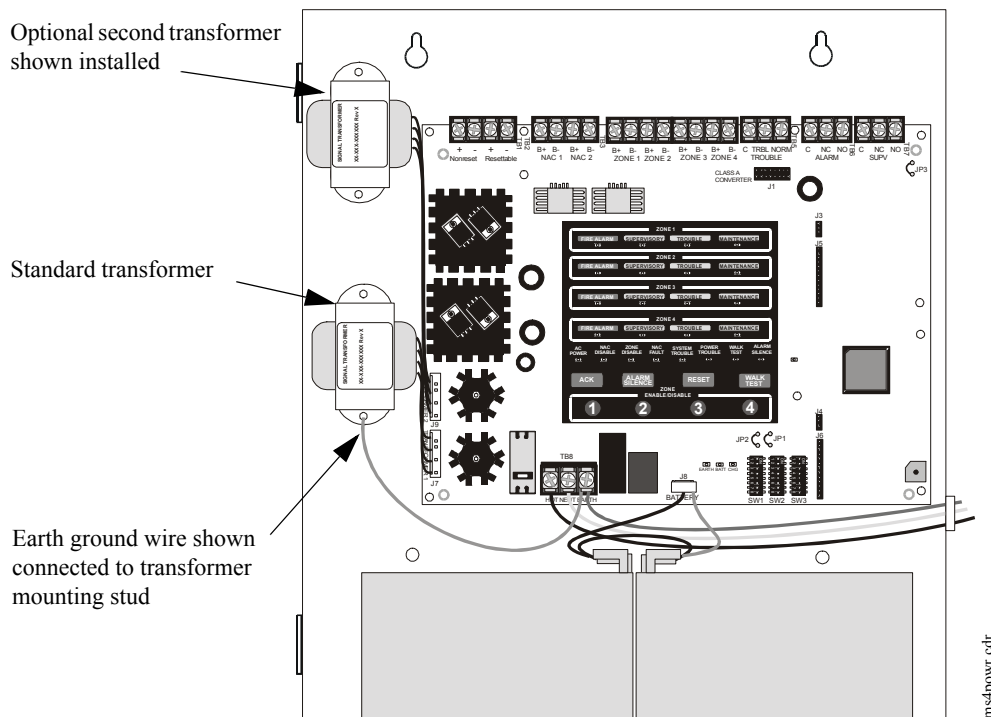

Figure 2.3 Operating Power Connections

2.3 Input Circuits

The SK-2 has two IDCs (Initiating Device Circuits) and the SK-4 has four IDCs. Each circuit is compatible with System Sensor's I³ smoke detectors which generate a maintenance signal when the detector becomes dirty and a separate supervisory 'freeze' signal when ambient temperature falls below the detector rating. The maximum loop resistance limit for each IDC is 100 ohms. The field wiring for each zone is supervised for opens, shorts and ground faults (zero impedance to ground). All conditions are visually and audibly annunciated.

Each circuit is configured for Style B (Class B) operation and will accept I³ smoke detectors, any normally-open contact devices as well as conventional 2-wire or 4-wire, 24 VDC smoke detectors. In addition, Zone 1 (IDC 1) on the SK-2 and Zone 2 (IDC 2) on the SK-4 can be programmed as combination supervisory and waterflow zones. Refer to the SilentKnight Device Compatibility Document for a list of compatible devices.

SK-4 Initiating Device Circuits can be converted to Style D (Class A) by installing the optional Class A Converter module. Refer to "SK-CAC4 Class A Converter Module (SK-4 only)" on page 25.

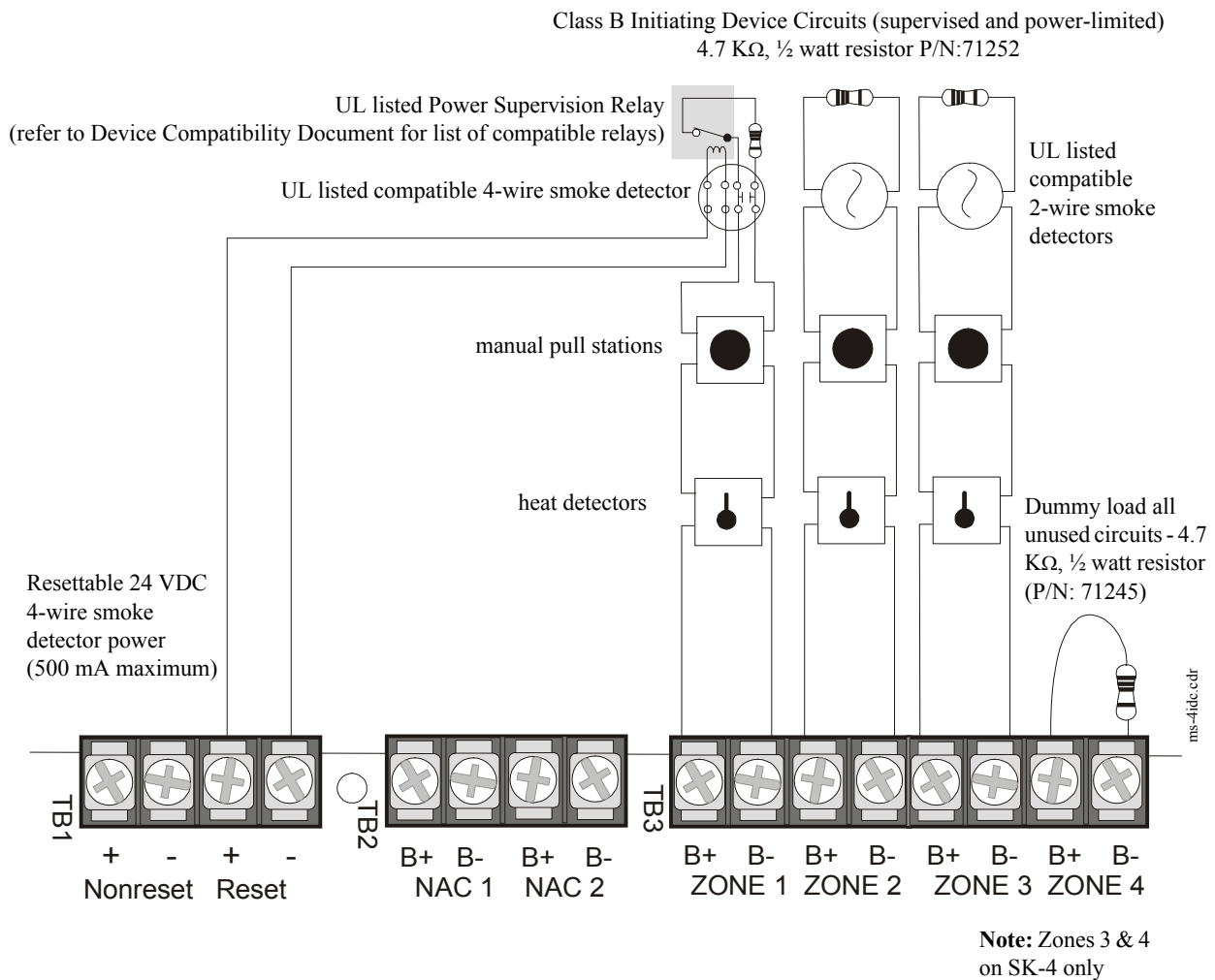

Figure 2.4 IDC Connections

Combination Waterflow/Supervisory Zone

A combination Waterflow/Supervisory circuit allows an FACP to distinguish between an Alarm switch (waterflow device) and a Supervisory switch (tamper) installed on the same circuit. The following figure illustrates the wiring of Zone 2 as a Style B (Class B) Waterflow/Supervisory circuit. Note that only Zone 1 on the SK-2 and Zone 2 on the SK-4 can be configured in this manner.

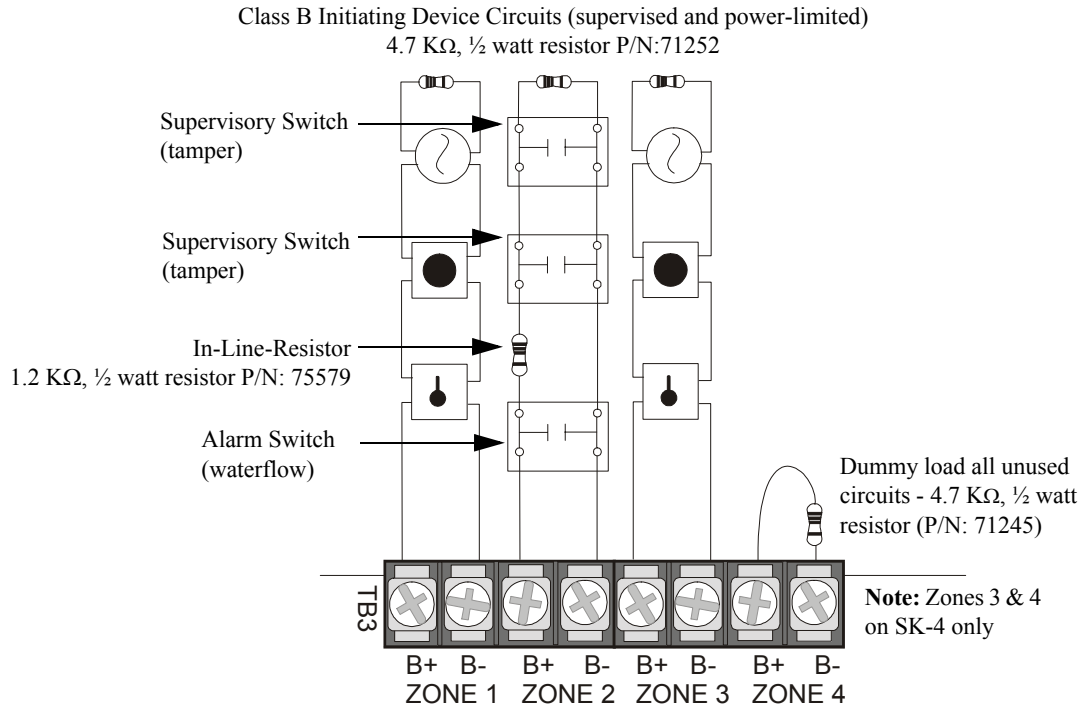

Figure 2.5 Style B Combination Circuit on Zone 2 of the SK-4

Requirements for the Combination Waterflow/Supervisory circuit are as follows:

- ✓ The Waterflow Alarm Switch(es) must connect to the FACP Initiating Device Circuit before the In-Line Resistor as shown in Figure 2.5
- ✓ The Waterflow Supervisory Switch(es) must connect to the FACP Initiating Device Circuit after the In-Line Resistor as shown in Figure 2.5
- ✓ Program the FACP Initiating Device Circuit #1 on the SK-2 or Circuit #2 on the SK-4 as a Combination circuit by placing SW1 DIP switch 8 to the ON position as described in "SW1 DIP Switch Settings" on page 34
- ✓ Waterflow Alarm Switch activation causes the panel to latch into alarm until the alarm condition is cleared and the FACP is reset
- ✓ Supervisory Switch activation causes the panel to track the supervisory condition, that is, the panel will clear when the supervisory condition is cleared (if FACP is programmed for Autoresettable Supervisory)

2.4 Output Circuits

2.4.1 Notification Appliance Circuits

The SK-2 provides one Style Y (Class B) NAC (Notification Appliance Circuit) while the SK-4 provides two Style Y (Class B) NACs. Each circuit is capable of providing a maximum of 2.5 amps of current. Total current drawn from these as well as other DC power outputs cannot exceed 3.0 amps for the SK-2 or 6.0 amps for the SK-4 with the optional second transformer installed (refer to battery calculations section). Each circuit is supervised and power-limited. Refer to the SilentKnight Device Compatibility Document for a listing of compatible notification appliances.

The SK-4 NACs can be converted to Style Z (Class A) by installing the optional Class A Converter module. Refer to "SK-CAC4 Class A Converter Module (SK-4 only)" on page 25.

Class B Notification Appliance Circuits (supervised and power-limited)
 4.7 K Ω , 1/2 watt resistor P/N:71252

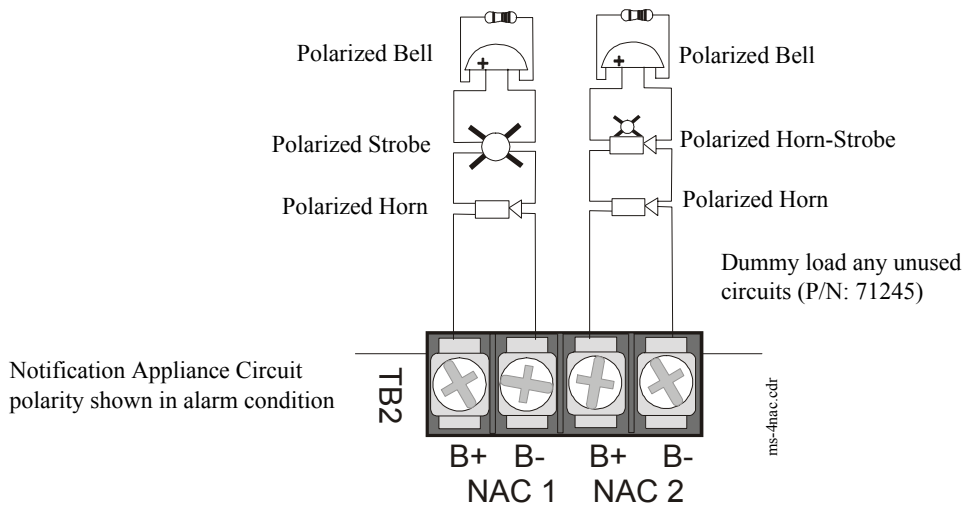

Figure 2.6 NAC Connections

2.4.2 Special Application DC Power Output Connections

Resettable 24 VDC special application power is available on both the SK-2 and SK-4 control panels. Nonresettable 24 VDC special application power is available only on the SK-4.

Nonresettable Power (500 mA) - SK-4 Only

24 VDC filtered, nonresettable special application power can be obtained from these terminals (power-limited)

4-Wire Smoke Detector Power (500 mA)

24 VDC filtered, resettable special application power for 4-wire smoke detectors can be obtained from these terminals (power-limited)

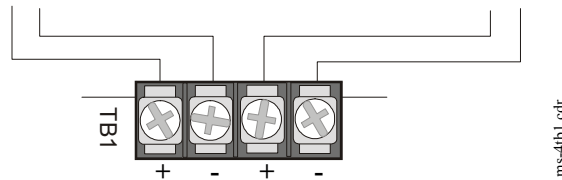

Figure 2.7 Special Application Power

2.4.3 Relays

The SK-2 and SK-4 control panels provide an alarm and fail-safe trouble relay and the SK-4 also provides a supervisory relay. Each Form-C relay is rated for 2 amps @ 30VAC (resistive).

Note that relay connections may be power-limited or nonpower-limited, provided that 0.25" minimum spacing is maintained between conductors of power-limited and nonpower-limited circuits.

Note: Relay contacts are shown with power applied to the panel and no active troubles, alarms or supervisories. The Trouble Relay is a fail-safe relay which will transfer on any trouble or total power failure.

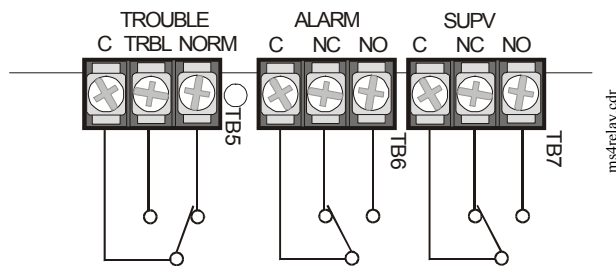

Figure 2.8 Relay Terminals

2.5 Power-limited Wiring Requirements

Power-limited and nonpower-limited circuit wiring must remain separated in the cabinet. All power-limited circuit wiring must remain at least 0.25" (6.35 mm) away from any nonpower-limited circuit wiring. Furthermore, all power-limited and nonpower-limited circuit wiring must enter and exit the cabinet through different knockouts and/or conduits. A typical wiring diagram for the SK-4 is illustrated below.

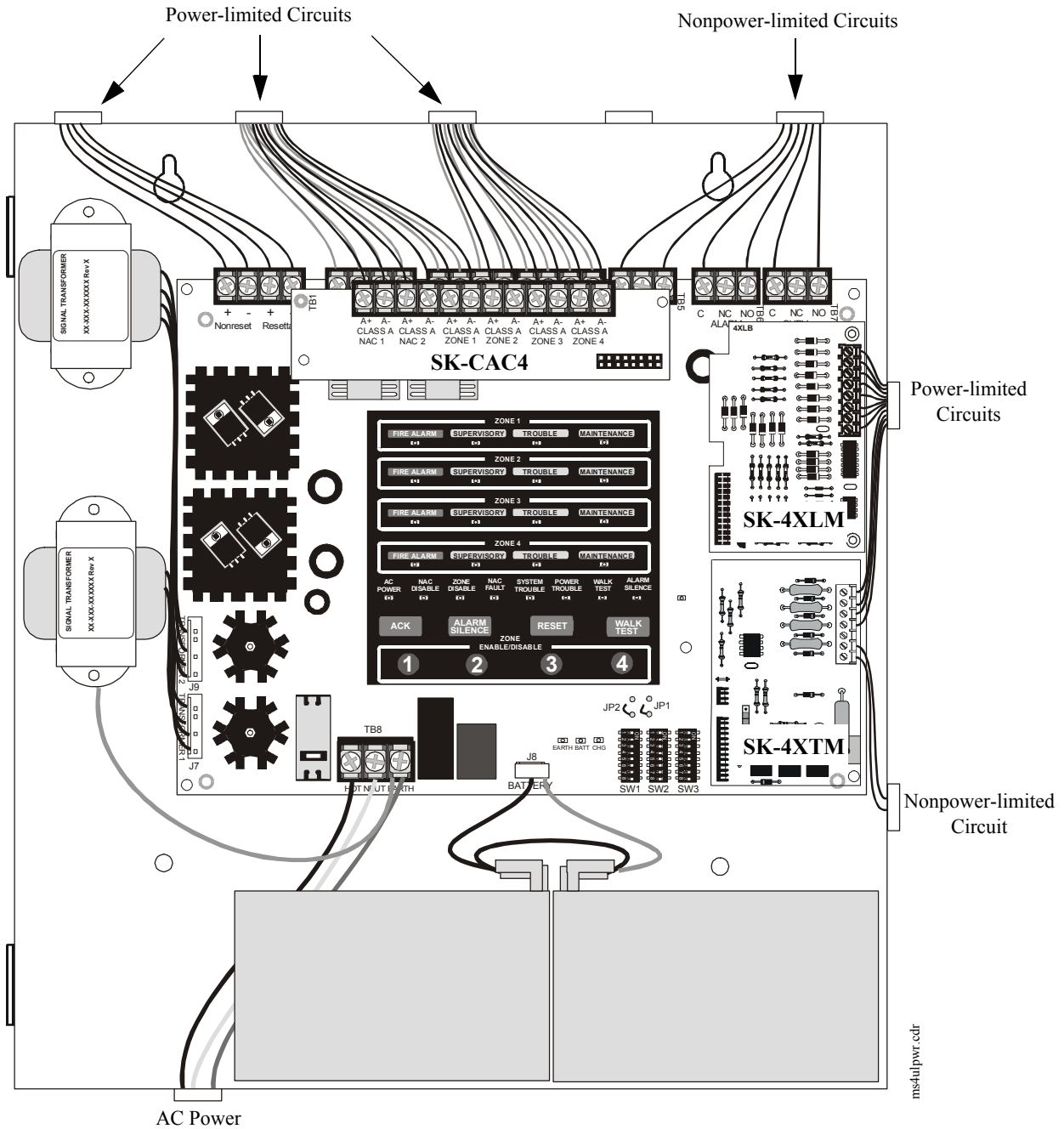

Figure 2.9 Typical UL Power-limited Wiring Requirements

2.6 Installation of Optional Modules



CAUTION: Remove all power (AC and DC) before installing or removing modules or wiring.

2.6.1 SK-CAC4 Class A Converter Module (SK-4 only)

2.6.1.1 Installation

The SK-CAC4 Module can be used to convert the four Style B (Class B) Initiating Device Circuits to Style D (Class A) and the two Style Y (Class B) Notification Appliance Circuits to Style Z (Class A). The module plugs into connector J1 which is located at the top right of the SK-4 main circuit board.

Install the three supplied standoffs in the holes on the main circuit board as indicated in the following figure. Carefully align the connector on the SK-CAC4 with J1 on the FACP main circuit board and press the module securely into place. Make certain the pins are properly aligned to prevent bending or breaking of any connector pins.

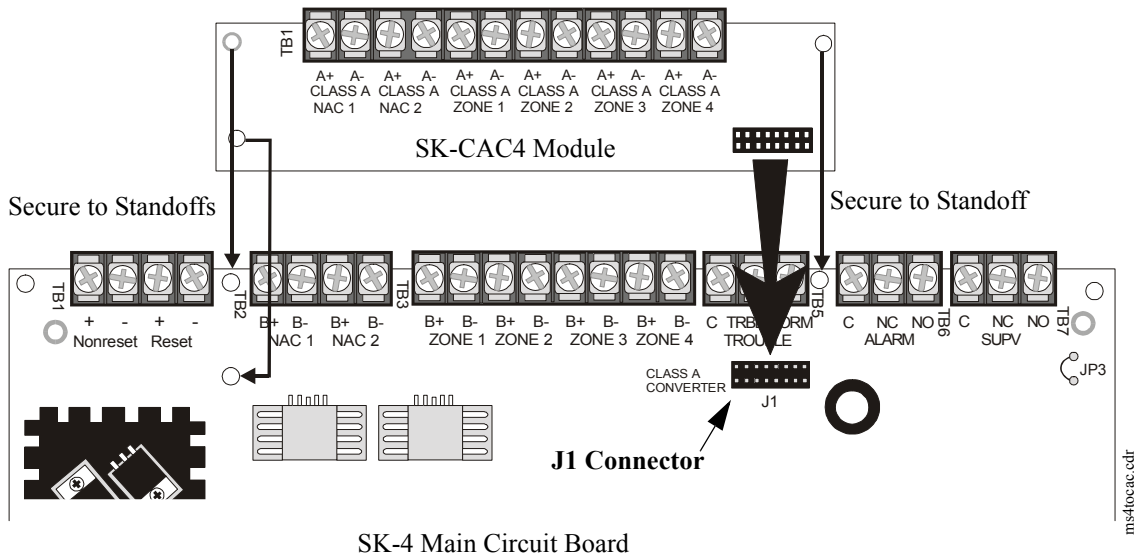

Figure 2.10 SK-CAC4 Module Installation

2.6.1.2 Wiring NACs and IDCs for Class A

Wire the Style Z (Class A) Notification Appliance Circuits using TB2 of the SK-4 and TB1 of the SK-CAC4 module. Wire the Style D (Class A) Initiating Device Circuits using TB3 of the SK-4 and TB1 of the SK-CAC4. Make certain to observe polarity when connecting the devices to the circuits. The B+ and A+ terminals must comprise the feed and return for the positive side of a device and the B- and A- terminals must comprise the feed and return for the negative side of a device. To configure any of the zones for Class B when the SK-CAC4 is installed, simply wire to the B+ and B- input on the FACP terminal(s) and install the End-of-Line Resistor after the last device on the circuit. Do not wire to the corresponding A+ and A- terminals on the SK-CAC4 module. Note that Zone 1 IDC on the SK-2 and Zone 2 IDC on the SK-4 can be configured as a combination waterflow/supervisory circuit as illustrated in the following figure.

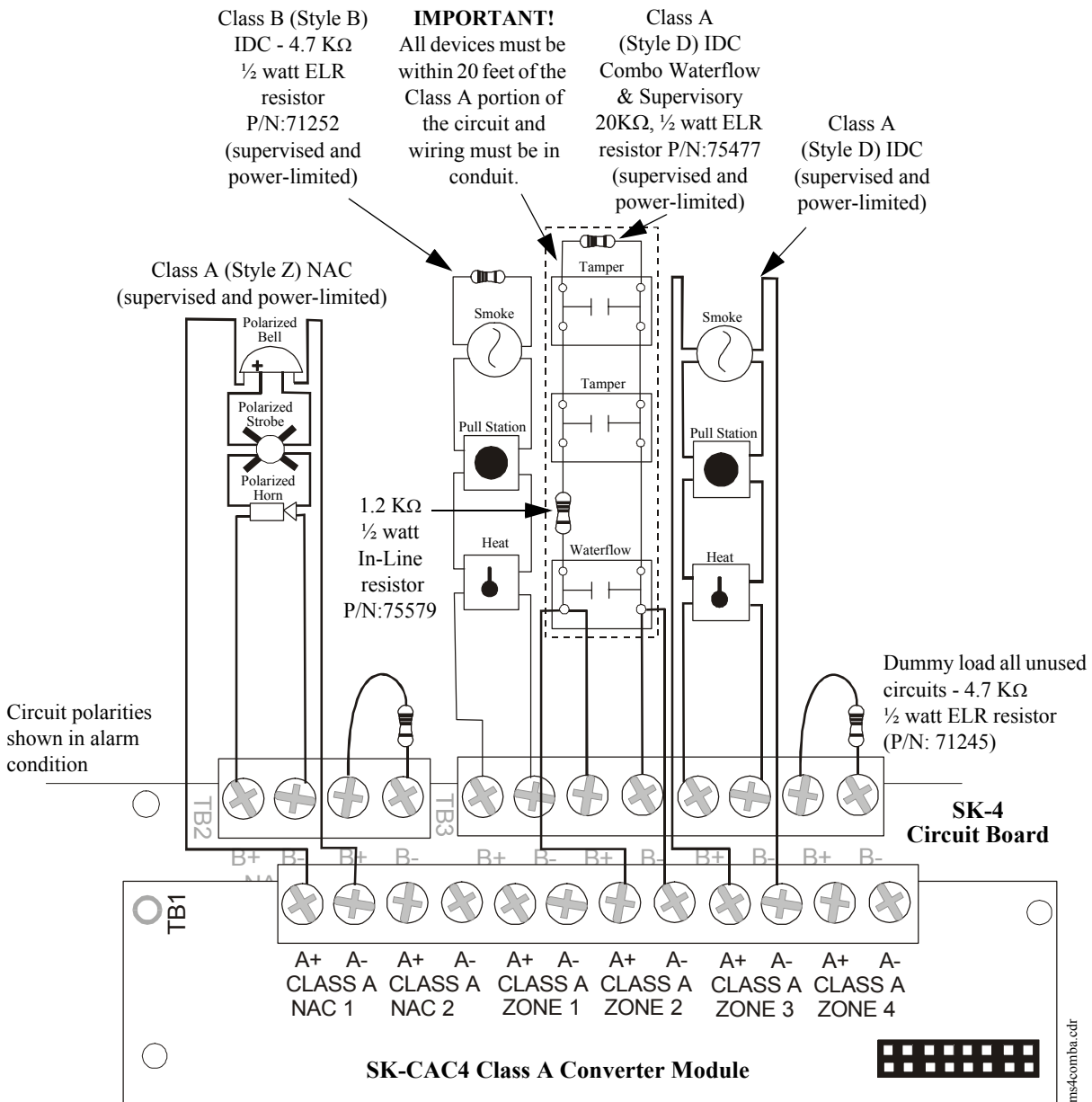

Figure 2.11 Wiring NACs and IDCs for Class A Operation

2.6.2 SK-4XTM, SK-4XLM and SK-4XZM Option Modules

SK-4: The SK-4XLM LED Interface Module can only be plugged into connectors J3 and J5 on the SK-4 main circuit board. The SK-4XTM and SK-4XZM modules can be plugged into connectors J3 and J5 or J4 and J6 on the SK-4 main circuit board. A combination of any two of the three modules can be installed.

SK-2: Only the SK-4XTM module can be plugged into connectors J3 & J5 on the SK-2 main circuit board. (*No other option modules can be installed on the SK-2*).

The following steps must be followed when installing each of these modules:

1. Remove all power (AC and DC) from the FACP before installing the modules
2. Cut jumper JP1 (for connectors J3 and J5) and/or JP2 (for connectors J4 and J6) on the main circuit board to allow the control panel to supervise the placement of any installed option module
3. Install the two supplied metal standoffs in the locations indicated. These standoffs provide the required earth ground protection
4. Carefully plug the connectors on the option module into connectors J3 and J5 or J4 and J6 on the FACP main circuit board, being careful not to bend any pins
5. Secure the option module to the standoff on the main circuit board with the supplied screws
6. When the installation has been completed, connect the wiring to the modules as indicated in the following sections
7. Test system for proper operation

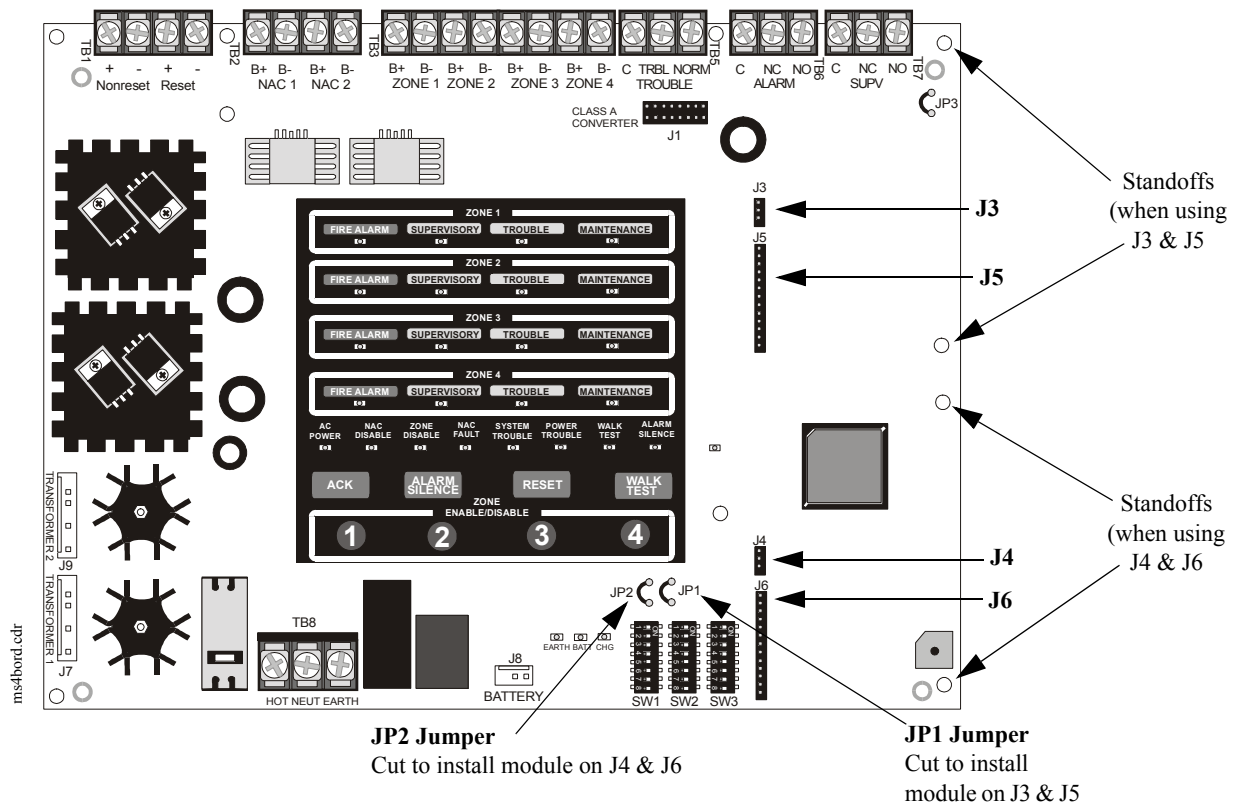

Figure 2.12 4X Option Module Connection to SK-4

2.6.2.1 SK-4XTM Transmitter Module Installation

The SK-4XTM provides a supervised output for a local energy municipal box transmitter in addition to alarm and trouble reverse polarity. A jumper option allows the reverse polarity circuit to open with a system trouble condition if no alarm condition exists. A disable switch allows disabling of the transmitter output during testing to prevent accidental calling of the monitoring service.

Local Energy Municipal Box Service (NFPA 72 Auxiliary Fire Alarm Systems):

- Supervisory Current: 5.0 mA
- Trip Current: 350 mA (subtracted from notification appliance power)
- Coil Voltage: 3.65 VDC
- Maximum Coil Resistance: 14.6 ohms
- Maximum allowable wire resistance between panel and trip coil: 3 ohms
- Municipal Box wiring can leave the building

Remote Station Service (NFPA 72 Remote Station Fire Alarm Systems) - Intended for connection to a polarity reversal circuit or a Remote Station receiving unit having compatible ratings:

- Maximum load for each circuit: 10 mA
- Reverse polarity output voltage: 24 VDC
- Remote Alarm and Remote Trouble wiring can leave the building

Before installing the module, place the disconnect switch to the down (disconnect) position to prevent accidental activation of the municipal box. Note that a Disconnect LED will illuminate after the module is installed in the FACP. In addition, the System Trouble LED will turn on to indicate the Disconnect condition.

Note: SK-4XTM Module is not suitable for transmitting reverse polarity supervisory signal.

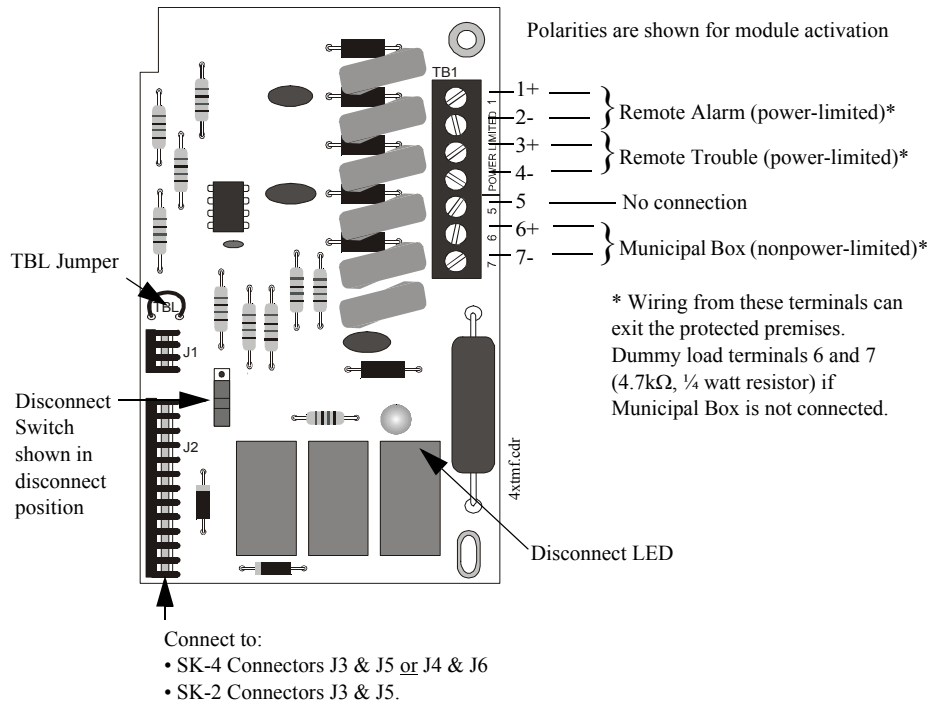
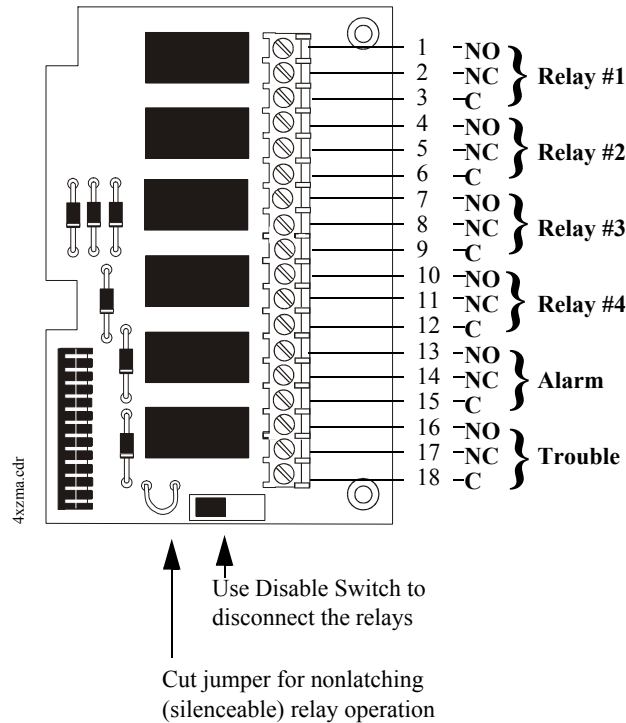

Figure 2.13 SK-4XTM Transmitter Module

2.6.2.2 SK-4XZM Zone Relay Module (SK-4 only)

The SK-4XZM provides four zone alarm, one system alarm and one system trouble Form-C relays. Nonpower-limited and power-limited wiring must have a minimum distance of 0.25", wire to wire. If this module is used to drive nonpower-limited and power-limited circuits, follow the instructions below:

Relay #1 through #4 will activate with Output #1 through #4 and remain latched unless 'LATCH' jumper is cut.



1) Skip a set of dry contacts to maintain the 0.25" required space between power-limited and nonpower-limited circuits. The wiring of this module must follow the requirements as specified in "Power-limited Wiring Requirements" on page 24.

OR

2) If this module is needed to drive power-limited and nonpower-limited relays that are next to each other, refer to the following illustration which shows a typical connection:

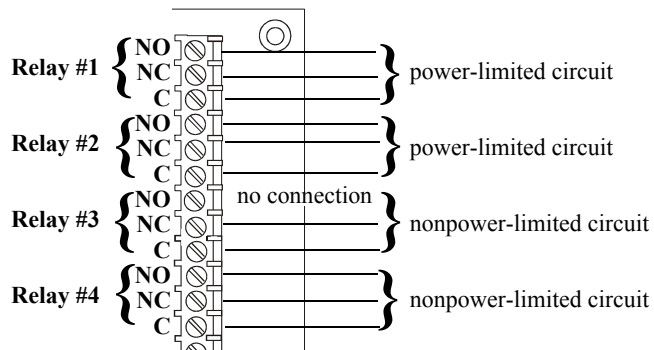

Figure 2.14 SK-4XZM Zone Relay Module

2.6.2.3 SK-4XLM LED Interface Module (SK-4 only)

The SK-4XLM supports the SK-RZA4 Remote Annunciator module. The wiring of this module must follow the requirements as specified in "Power-limited Wiring Requirements" on page 24.

Important: The SK-4XLM module can only be installed on connectors J3 and J5 of the SK-4 main circuit board.

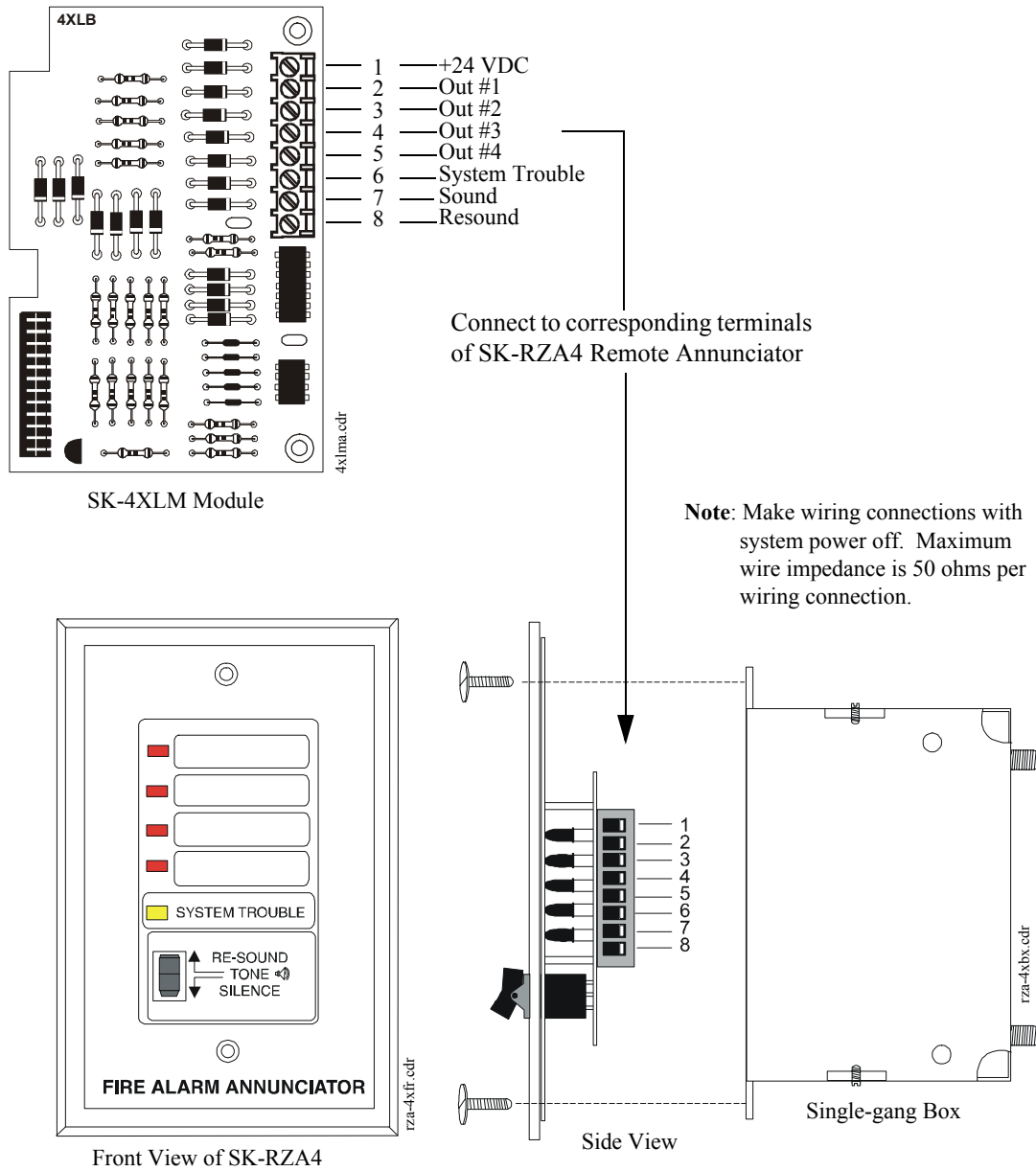

Figure 2.15 SK-4XLM LED Interface Module

SECTION 3 Program Options via DIP Switch

NOTICE TO USERS, INSTALLERS, AUTHORITIES HAVING JURISDICTION AND OTHER INVOLVED PARTIES			
This product incorporates field-programmable software. In order for the product to comply with the requirements in the Standard for Control Units and Accessories for Fire Alarm Systems, UL 864, certain programming features or options must be limited to specific values or not used at all as indicated below.			
Program feature or option	Permitted in UL 864? (Y/N)	Possible settings	Settings permitted in UL 864
Alarm Verification	Y	Refer to Table 3.1 on page 32 and Table 3.2 on page 33	Alarm Verification OFF

This section describes the programming options available via DIP switch settings. The FACP can be field programmed using option DIP switches SW1, SW2 and SW3 which are located in the bottom right side of the main circuit board. Refer to the following illustration for switch locations and DIP switch placement in the ON and OFF positions.

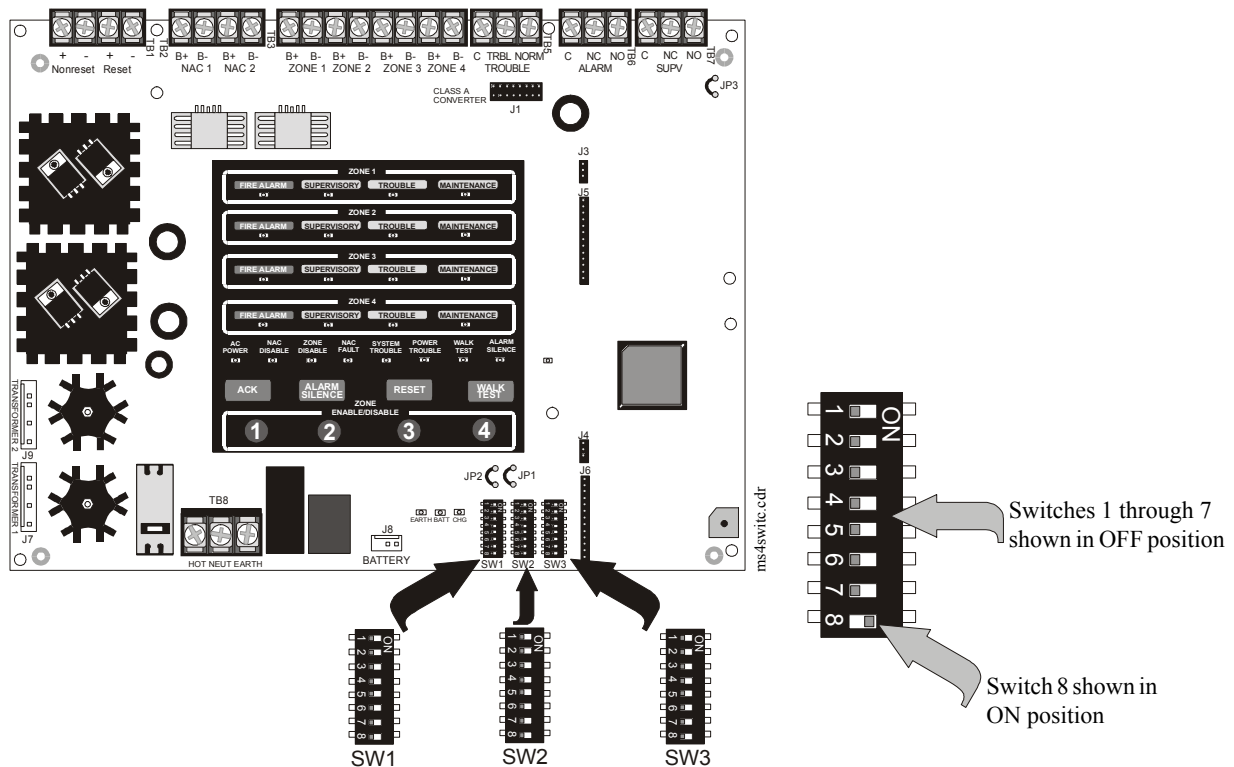

Figure 3.1 Field Programming DIP Switches

3.1 DIP Switch Settings

The following tables list the programmable features for the SK-2 and SK-4. Placing a DIP switch in the ON position will select the feature while placing the DIP switch in the OFF position will deselect the feature. The exceptions to this rule are SW3 DIP switches 5 & 6. These two switches are used to select the Notification Appliance Circuit synchronization feature. A detailed description of each feature is presented in the following pages.

Important: When any programmable feature is changed by repositioning a DIP switch, the FACP Reset button must be pressed to ensure that the control panel can read the new switch position.

Table 3.1 SK-2 DIP Switch Settings

Switch Number	DIP Switch Number	DIP Switch ON	
SW1	1	Silence Inhibit	
	2	Auto-silence	
	3	Temporal Coding	
	4	Selective Silence (if sync. enabled)	
	5	Trouble Reminder	
	6	AC Trouble Delay	
	7	Autoresettable Supervisory	
	8	IDC Combination Waterflow/ Supervisory Circuit	
SW2	1	<i>not used</i>	
	2	<i>not used</i>	
	3	IDC1 Verification	
	4	IDC1 Supervisory	
	5	IDC2 Verification	
	6	IDC2 Supervisory	
	7	<i>not used</i>	
	8	<i>not used</i>	
SW3	1	NAC1 Nonsilenceable	
	2	NAC1 Disable	
	3	<i>not used</i>	
	4	<i>not used</i>	
	5 & 6 used to select strobe synchronization feature as shown to the right	Switch 5 Switch 6	
		No Synchronization	OFF OFF
		System Sensor Synchronization	ON OFF
		Gentex Synchronization	OFF ON
		Wheelock Synchronization	ON ON
	7	Nonsilenceable Waterflow for Combination Circuit (only if SW1 switch 8 is ON)	
8	spare		

Table 3.2 SK-4 DIP Switch Settings

Switch Number	DIP Switch Number	DIP Switch ON		
SW1	1	Silence Inhibit		
	2	Auto-silence		
	3	Temporal Coding		
	4	Selective Silence (if sync. enabled)		
	5	Trouble Reminder		
	6	AC Trouble Delay		
	7	Autoresettable Supervisory		
	8	IDC Combination Waterflow/ Supervisory Circuit		
SW2	1	IDC1 Verification		
	2	IDC1 Supervisory		
	3	IDC2 Verification		
	4	IDC2 Supervisory		
	5	IDC3 Verification		
	6	IDC3 Supervisory		
	7	IDC4 Verification		
	8	IDC4 Supervisory		
SW3	1	NAC1 Nonsilenceable		
	2	NAC1 Disable		
	3	NAC2 Nonsilenceable		
	4	NAC2 Disable		
	5 & 6 used to select strobe synchronization feature as shown to the right	No Synchronization	Switch 5 OFF	Switch 6 OFF
		System Sensor Synchronization	ON	OFF
		Gentex Synchronization	OFF	ON
		Wheelock Synchronization	ON	ON
	7	Nonsilenceable Waterflow for Combination Circuit (only if SW1 switch 8 is ON)		
	8	spare		

3.1.1 SW1 DIP Switch Settings

3.1.1.1 Silence Inhibit

Switch 1, placed in the ON position, selects the Silence Inhibit feature. This feature prevents the silencing or resetting of the NACs (Notification Appliance Circuits) for a period of one minute after initiation of an alarm. Placing switch 1 to the OFF position deselects the Silence Inhibit feature. The factory default setting is switch 1 OFF for no Silence Inhibit.

3.1.1.2 Auto-silence

Switch 2, placed in the ON position, selects the Auto-silence feature. This feature automatically silences all NACs, programmed for silenceable operation, ten minutes after alarm activation. A new activation on another zone will resound the NACs. The factory default setting is switch 2 OFF for no Auto-silence.

3.1.1.3 Temporal Coding

Switch 3, placed in the ON position, selects the Temporal Coding feature. This feature causes the NACs to pulse, ½ second on, ½ second off, ½ second on, ½ second off, ½ second on, 1½ seconds off, continually repeating this pattern while activated. The factory default setting is switch 3 OFF for no Temporal Coding, which will cause the NACs to sound a steady signal when activated.

Note that Temporal Coding is disabled if Strobe Synchronization is enabled.

3.1.1.4 Selective Silence

Switch 4, placed in the ON position, selects the Selective Silence feature. This feature allows the use of various manufacturer's horn strobe mute protocols. When Selective Silence is enabled and the Synchronization feature is selected (refer to "Strobe Synchronization" on page 37), pressing the Silence button will turn off all silenceable audible devices while leaving on the visual devices, such as strobes. The factory default setting is switch 4 OFF for no Selective Silence.

Note: Enabling Selective Silence but not Synchronization will cause audible and visual devices to be turned off when the Silence button is pressed.

3.1.1.5 Trouble Reminder

Switch 5, placed in the ON position, selects the Trouble Reminder feature. This feature causes the FACP piezo to sound every 15 seconds for alarms and every two minutes for troubles after the alarms or troubles have been silenced. In addition, the piezo will resound 24 hours after a trouble has been silenced but not cleared. The factory default setting is switch 5 OFF for Trouble Reminder disabled.

3.1.1.6 AC Trouble Delay

Switch 6, placed in the ON position, selects the AC Trouble Delay feature. This feature allows the FACP to delay trouble activation for six hours following an AC loss or brownout condition. The factory default setting is switch 6 OFF for no AC Trouble Delay.

3.1.1.7 Autoresettable Supervisory

Switch 7, placed in the ON position, selects the Autoresettable Supervisory feature. This feature causes the IDCs (Initiating Device Circuits), programmed as supervisory circuits, to automatically reset (nonlatching) after the alarm condition has been cleared. The factory default setting is switch 7 OFF for no Autoresettable Supervisory.

3.1.1.8 IDC Combination Circuit

Switch 8, placed in the ON position, sets IDC #1 on the SK-2 or IDC #2 on the SK-4 as a combination circuit. A combination zone can be used for monitoring supervisory devices such as valve tamper switches and alarm devices such as waterflow switches. Supervisory conditions, which latch via software, can be silenced by pressing the Acknowledge and then Silence buttons. The factory default setting is switch 8 OFF for no Combination circuit.

3.1.2 SW2 DIP Switch Settings

3.1.2.1 IDC1 Verification (SK-4 only)

Switch 1 only on the SK-4, placed in the ON position, selects the Verification feature for IDC (Initiating Device Circuit) #1. When Verification is selected the following events will occur when a smoke detector activates:

1. FACP removes power from all zones for 6 seconds, resetting all smoke detectors
2. Power is reapplied and a 12 second retard period begins, allowing detectors to stabilize
3. During the 18 second reset/retard periods of steps 1 & 2, subsequent alarms by the same zone are ignored
4. Alarms detected on any other zone during the retard period will cause the FACP to immediately process the alarm
5. A 60 second confirmation period follows the reset/retard period. If an alarm occurs during the confirmation period, on the zone which initiated verification, the FACP will immediately process the alarm. If no alarm is detected during this confirmation period, the FACP returns to normal condition

Important! Circuits selected for verification must have only smoke detectors installed

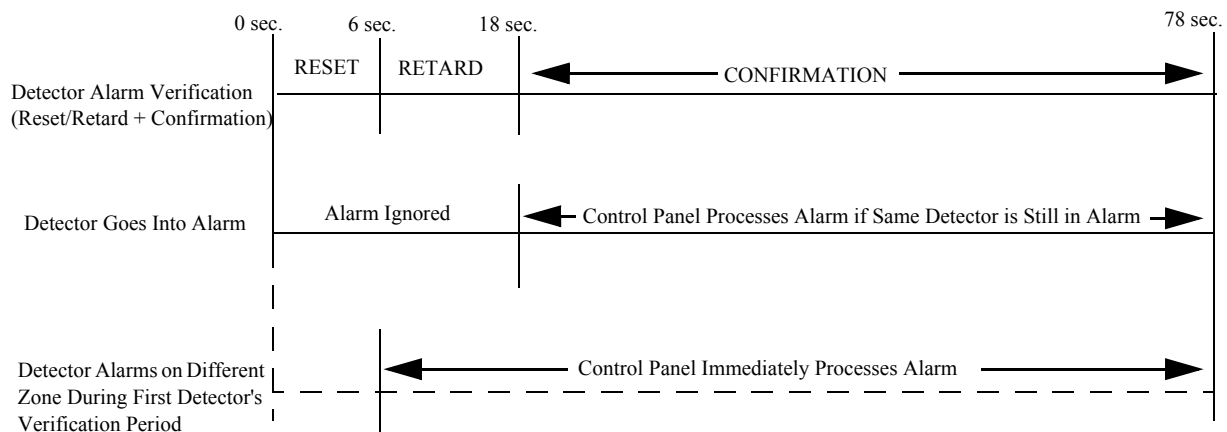

The factory default setting is switch 1 OFF for no IDC1 Verification.

3.1.2.2 IDC1 Supervisory (SK-4 only)

Switch 2 only on the SK-4, placed in the ON position, programs IDC #1 as a Supervisory circuit. A supervisory zone can be used for monitoring supervisory devices such as sprinkler tamper switches. A supervisory activation will pulse the piezo sounder at a " second rate and flash the zone supervisory LED at the same rate. The factory default setting is switch 2 OFF for no IDC1 Supervisory.

3.1.2.3 IDC1 Verification for SK-2 or IDC2 Verification for SK-4

Switch 3, placed in the ON position, selects the Verification feature for IDC #1 on the SK-2 or IDC #2 on the SK-4. The factory default setting is switch 3 OFF for no Verification. Refer to IDC1 Verification (SK-4 only) for a description of this feature.

3.1.2.4 IDC1 Supervisory for SK-2 or IDC2 Supervisory for SK-4

Switch 4, placed in the ON position, programs IDC #1 on the SK-2 or IDC #2 on the SK-4 as a Supervisory circuit. A supervisory zone can be used for monitoring supervisory devices such as sprinkler tamper switches. A supervisory activation will pulse the piezo sounder at a " second rate and flash the zone supervisory LED at the same rate. The factory default setting is switch 2 OFF for no Supervisory.

3.1.2.5 IDC2 Verification for SK-2 or IDC3 Verification for SK-4

Switch 5, placed in the ON position, selects the Verification feature for IDC #2 on the SK-2 or IDC #3 on the SK-4. The factory default setting is switch 5 OFF for no Verification. Refer to "IDC1 Verification (SK-4 only)" on page 35 for a description of this feature.

3.1.2.6 IDC2 Supervisory for SK-2 or IDC3 Supervisory for SK-4

Switch 6, placed in the ON position, programs IDC #2 on the SK-2 or IDC #3 on the SK-4 as a Supervisory circuit. A supervisory zone can be used for monitoring supervisory devices such as sprinkler tamper switches. A supervisory activation will pulse the piezo sounder at a " second rate and flash the zone supervisory LED at the same rate. The factory default setting is switch 6 OFF for no Supervisory.

3.1.2.7 IDC4 Verification (SK-4 only)

Switch 7 only on the SK-4, placed in the ON position, selects the Verification feature for IDC #4. The factory default setting is switch 7 OFF for no IDC4 Verification. Refer to "IDC1 Verification (SK-4 only)" on page 35 for a description of this feature.

3.1.2.8 IDC4 Supervisory (SK-4 only)

Switch 8 only on the SK-4, placed in the ON position, programs IDC #4 as a Supervisory circuit. A supervisory zone can be used for monitoring supervisory devices such as sprinkler tamper switches. A supervisory activation will pulse the piezo sounder at a " second rate and flash the zone supervisory LED at the same rate. The factory default setting is switch 8 OFF for no IDC4 Supervisory.

3.1.3 SW3 DIP Switch Settings**3.1.3.1 NAC1 Nonsilenceable**

Switch 1, placed in the ON position, programs NAC #1 as a nonsilenceable circuit. Selecting this feature will prevent the notification appliances on NAC #1 from being silenced by the Autosilence feature or by pressing the Alarm Silence button. The factory default setting is switch 1 OFF for silenceable circuit.

3.1.3.2 NAC1 Disable

Switch 2, placed in the ON position, will disable NAC #1, preventing the notification appliances from activating. This feature may be used during maintenance or while testing the system to prevent building evacuation. The FACP will indicate an NAC disabled fault and system trouble while this feature is selected. The factory default setting is switch 2 OFF for NAC1 enabled.

3.1.3.3 NAC2 Nonsilenceable (SK-4 only)

Switch 3 only on the SK-4, placed in the ON position, programs NAC #2 as a nonsilenceable circuit. Selecting this feature will prevent the notification appliances on NAC #2 from being silenced by the Autosilence feature or by pressing the Alarm Silence button. The factory default setting is switch 3 OFF for silenceable circuit.

3.1.3.4 NAC2 Disable (SK-4 only)

Switch 4 only on the SK-4, placed in the ON position, will disable NAC #2, preventing the notification appliances from activating. This feature may be used during maintenance or while testing the system to prevent building evacuation. The FACP will indicate an NAC disabled fault and system trouble while this feature is selected. The factory default setting is switch 4 OFF for NAC2 enabled.

3.1.3.5 Strobe Synchronization

Switches 5 and 6 are used to program the Synchronization feature. This feature controls the activation of notification appliances in such a way that all devices will turn on and off at exactly the same time. This is particularly critical when activating strobes which must be synchronized to avoid random activation and a potential hazard or confusion. The FACP can be programmed to operate with a variety of manufacturer's devices. The following table lists the required switch settings to accomplish synchronization:

Synchronization Feature	Switch 5	Switch 6
No Synchronization	OFF	OFF
System Sensor Synchronization	ON	OFF
Gentex Synchronization	OFF	ON
Wheelock Synchronization	ON	ON

The factory default setting is switches 5 and 6 OFF for No Synchronization.

3.1.3.5.1 Maximum Number of Strobes for Synchronization

The total current draw for each Notification Appliance Circuit cannot exceed 2.5 amps. Refer to the manufacturer's documentation supplied with the strobes to determine the maximum current draw for each strobe and ensure that the circuit maximum is not exceeded.

To ensure proper strobe and circuit operation, there is also a limit to the number of strobes that can be attached to each circuit. Following is a list of the strobes that have been tested with this FACP and the maximum number that can be connected to each NAC. *Make sure that the NAC maximum current is not exceeded:*

- ✓ System Sensor: 40 Strobes
- ✓ Wheelock: 25 Strobes
- ✓ Gentex: 23 Strobes

3.1.3.6 Nonsilenceable Waterflow for Combination Circuit

If SW1 switch 8 is set to the ON position to select a Combination Waterflow/Supervisory Circuit (refer to "IDC Combination Circuit" on page 34) and SW3 switch 7 is set to the ON position to select the Nonsilenceable Waterflow for the Combination Circuit option, the following conditions will occur:

- SK-2 - NACs become nonsilenceable upon activation of IDC #1 (Combination Circuit)
- SK-4 - NACs become nonsilenceable upon activation of IDC #2 (Combination Circuit)

Notes:

- 1.If initial alarm activations are from IDCs other than the Combination Circuit, the NACs will be either silenceable or nonsilenceable, depending on the setting of SW3 switches 1 and 3 (refer to "NAC1 Nonsilenceable" on page 36 and "NAC2 Nonsilenceable (SK-4 only)" on page 36).
- 2.If alarm activation is from the Combination Circuit programmed for nonsilenceable, all NACs will be nonsilenceable regardless of subsequent IDC activations.

3.1.3.7 Spares

Switch 8 is a spare switch and has no function at this time. The switch should therefore be left in the factory default setting of OFF.

SECTION 4

Operating Instructions

The SK-2 and SK-4 have two modes of operation which are Normal and Walktest modes. Upon initial power-up, the system will be in Normal Mode. This section discusses operation of the control panel in the Normal Mode.

4.1 Switch Functions in Normal Mode

4.1.1 ACK - Acknowledge

The Acknowledge button, which is located on the FACP membrane switch panel, silences the system piezo sounder and changes all flashing system LEDs to on steady. Pressing the Acknowledge button will have no effect on the Notification Appliance Circuits. To activate, press and hold the Acknowledge button for a minimum of one second.

4.1.2 Silence

Pressing the Silence button, which is located on the FACP membrane switch panel, silences the system piezo sounder, turns off the silenceable Notification Appliance Circuits and turns on the Alarm Silence LED. *The Silence button will be ignored for nonsilenceable waterflows and NACs.* Upon the occurrence of a subsequent event (alarm or trouble), Silence is overridden and the control panel will respond to the new event. To activate, press the Silence button for a minimum of one second.

Note: If Silence Inhibit has been enabled, NACs cannot be silenced for one minute following initiation of an alarm.

4.1.3 Zone Enable/Disable

To disable a zone, press the corresponding Zone Enable/Disable button. The Zone Disable and system Trouble LEDs will blink, as well as the Trouble LED for the disabled zone. To enable the zone, press the Zone Enable/Disable button a second time.

4.1.4 Reset/(Lamp Test)

The system Reset button, which is located on the FACP membrane switch panel, resets the system and any smoke detectors. Each press of the Reset button will cause the following:

- ✓ Clear all status LEDs
- ✓ Turn off the Notification Appliance Circuits
- ✓ Reset all zones by temporarily removing power
- ✓ Silence the onboard piezo sounder
- ✓ Restore all system relays to normal
- ✓ Temporarily remove power from the resettable power output

Note: if Silence Inhibit is active, a panel reset cannot occur for one minute.

Any alarm, supervisory or trouble condition that exists after a system reset will resound the system, reactivating appropriate system activity. Any zones that were disabled before the reset will be disabled after the reset.

Lamp Test - When the Reset button is pressed and then released, the FACP will perform a Lamp Test. All panel LEDs will be turned on and the piezo will sound for approximately two seconds.

4.1.5 Walktest

The Walktest button, which is located on the FACP membrane switch panel, allows a panel walktest to be performed. Pressing and holding the Walktest button for a minimum of two seconds causes the FACP to enter audible walktest. Pressing the Walktest button and then the Silence button and holding both for a minimum of two seconds will cause the panel to enter silent walktest. Walktest can be exited by pressing and holding the Walktest button for a minimum of three seconds or by pressing the Reset button. Refer to “Walktest” for a complete description of this feature.

4.2 Walktest

Walktest allows the testing of all control panel IDCs (input zones). An audible or silent walktest may be performed.



It is important to note that while the FACP is in Walktest mode, the control panel is in an off-normal condition and does not provide fire protection.

It should also be noted that the trouble relay will be activated while the control panel is in Walktest mode. Placing the control panel into Walktest mode will only be possible if the system has no active alarms.

Prior to initiating a walktest, check to make certain that **all system faults have been cleared**. Upon entering Walktest mode, the following conditions should occur:

- Trouble relay will activate
- Alarm relay will be disabled
- Supervision relay will be disabled (SK-4 only)
- Piezo sounder will be disabled
- F³ smoke detectors will enter their own test mode causing their LEDs to flash twice every five seconds (refer to the F³ specification document)
- All alarm conditions will be displayed as they occur by blinking zone alarm LED
- All zone troubles will be displayed as they occur by blinking zone trouble LED

During walktest, the FACP zone LEDs will blink for the first activation on a zone. Subsequent activations on the same zone will cause the corresponding zone LED to blink the number of alarms on the zone since the start of the test, followed by a two second pause and then a repeat of the sequence.

Note that following a zone activation, a 6 second reset for conventional and 60 second reset for F³ detectors is initiated. No new alarms or troubles will be detected during this reset period.

Disabled zones will not respond during Walktest. A zone may be disabled while in Walktest mode, should a faulty device be detected. This allows the user to return the system to Normal mode, enabling all other zones while preventing the faulty zone from triggering a false alarm.

Audible Walktest

To perform an audible Walktest, press and hold the Walktest button for a minimum of two seconds. The Trouble and Walktest LEDs will blink at a ¼ second rate.

While testing input devices, the first initiating device activated on a zone will cause the NACs to sound for four seconds. Subsequent device activations on the same zone will cause the NACs to turn on for one second. Any smoke detectors that are activated will automatically be reset by the panel. Zone faults (open circuits) will cause the NACs to remain on steadily until the fault is cleared.

During an audible walktest, if a device remains latched in alarm (such as a Pull Station that is not reset after activation), subsequent testing of devices on the same zone will not trigger the NACs. Be certain to reset or clear each device after testing.

Silent Walktest

To perform a silent Walktest, press the Walktest button, then press the Alarm Silence button and hold both for a minimum of two seconds. The Trouble, Walktest and Alarm Silence LEDs will blink at a ¼ second rate.

A silent walktest will not activate the control panel Notification Appliance Circuits. All alarm and trouble conditions must be observed using the LEDs at the control panel as described in the previous sections.

Exiting Walktest Mode

Walktest mode can be exited by pressing and holding the Walktest button for a minimum of three seconds or by pressing the Reset button. *The time-out feature will cause the control panel to automatically exit Walktest mode if no button presses have occurred for one hour.*

4.3 Status LEDs

AC Power LED

A green LED that remains on while the AC power supply is within correct limits. *If this indicator fails to light under normal conditions, service the system immediately.*

NAC Disable LED

A yellow LED that blinks to indicate that a Notification Appliance Circuit has been disabled using the main circuit board DIP switches. The LED will turn on steady when the Acknowledge or Alarm Silence button is pressed.

Zone Disable LED

A yellow LED that blinks to indicate that one or more alarm zones have been disabled using the Zone Enable/Disable buttons. The disabled zone's trouble LED will also be on. The Acknowledge or Alarm Silence button does not affect the Zone Disable LED.

NAC Fault LED

A yellow LED that blinks to indicate that an NAC trouble condition exists in the system. The LED turns on steady when the Acknowledge or Alarm Silence button is pressed.

System Trouble LED

A yellow LED that blinks to indicate that a system fault or abnormal condition exists and that the fire alarm system may be inoperative. It turns on steady when the Acknowledge or Alarm Silence button is pressed.

Power Trouble LED

A yellow LED that blinks to indicate an AC power, battery or charger trouble condition. It turns on steady when the Acknowledge or Alarm Silence button is pressed.

Walktest LED

A yellow LED that blinks to indicate that the control panel is in Walktest mode. The Acknowledge and Alarm Silence buttons do not affect the Walktest LED.

Alarm Silence LED

A yellow LED that turns on to indicate that an Alarm condition exists in the system but the Notification Appliance Circuits and the local piezo sounder have been silenced.

Zone Fire Alarm LED

A red LED for each zone that blinks to indicate that an alarm exists on the corresponding zone. It turns on steady when the Acknowledge or Alarm Silence button is pressed.

Zone Supervisory LED

A yellow LED for each zone that blinks if the zone has been programmed for supervisory and a supervisory condition exists on the corresponding zone. It turns on steady when the Acknowledge or Alarm Silence button is pressed.

Note that an I³ smoke detector freeze condition is displayed as a supervisory condition. The zone does not have to be programmed as a supervisory for this to occur.

Zone Trouble LED

A yellow LED for each zone that blinks to indicate that a trouble exists on the corresponding zone. It turns on steady when the Acknowledge or Alarm Silence button is pressed.

Zone Maintenance LED

A yellow LED for each zone that blinks to indicate that a I³ smoke detector on the corresponding zone is dirty or in need of maintenance. It turns on steady when the Acknowledge or Alarm Silence button is pressed.

Earth Fault LED (on main circuit board)

A yellow LED that blinks to indicate a ground fault condition on the system. A ground fault occurs when zero impedance between the FACP and earth ground exists. The LED turns on steady when the Acknowledge or Alarm Silence button is pressed.

Battery Fault LED (on main circuit board)

A yellow LED that blinks to indicate a low battery or no battery condition on the FACP. It turns on steady when the Acknowledge or Alarm Silence button is pressed.

Charger Fault LED (on main circuit board)

A yellow LED that blinks to indicate a battery charger fault. It turns on steady when the Acknowledge or Alarm Silence button is pressed.

4.4 Operation

Normal mode is the standard mode of operation. In this mode, the panel continuously monitors system status. When no alarm or trouble conditions exist, the control panel will be in the following state:

- all LEDs will be off (except the AC Power LED)
- the Notification Appliance Circuits will be off
- all relays are in their normal state
- the onboard piezo sounder will be off
- I3 smoke detectors will be polled for maintenance and freeze conditions on initial entry into Normal mode. Thereafter, each device will be polled every hour for freeze and every four hours for maintenance conditions

All alarm and system trouble conditions are annunciated on the control panel's LEDs.

Note: To ensure that the system is functioning properly, the FACP will perform a freeze check five minutes after the panel is reset, followed by a maintenance check. If there is no freeze or maintenance condition, the panel will continue to monitor for freeze conditions every hour and maintenance conditions every four hours.

4.4.1 Fire Alarm Response

The control panel will, upon detection of an alarm condition, cause the following:

- Latch the alarm condition - requires panel reset to clear alarm condition
- Blink the Zone Alarm LED one second On and one second Off
- Turn on remote annunciator alarm LED and piezo sounder
- Turn the Notification Appliance Circuit(s) on
- Turn the FACP piezo sounder on steady
- Turn on the alarm relay
- Start the Silence Inhibit, Auto-silence and Trouble Reminder functions if enabled

4.4.2 Fire Alarm Restoral

The control panel returns to normal after all alarms have been cleared and a system reset button has been pressed (pull stations have been reset, smoke detectors have reset and no smoke is present, waterflow has stopped). The control panel will perform the following upon restoral of all active alarms:

- Turn off the FACP Zone Alarm LED
- Turn off remote annunciator alarm LED and piezo sounder
- Turn off the Notification Appliance Circuit(s)
- Turn off the FACP piezo sounder
- Turn off the alarm relay
- I3 smoke detectors will be polled for maintenance and freeze conditions on initial entry into Normal mode. Thereafter, each device will be polled every hour for freeze and every four hours for maintenance conditions

4.4.3 System Supervisory Condition Response

Zones can be programmed for supervisory in applications where a waterflow sensing device has been employed and a sprinkler tamper switch is to be monitored. An I³ detector in a 'freeze' condition (detected abnormally low ambient temperature) will also generate a supervisory condition on its alarm zone (refer to the I³ specification sheet for temperature threshold). Any supervisory condition will cause the control panel to perform the following functions:

- Blink the FACP Zone Supervisory LED ½ second On and ½ second Off
- Pulse the piezo sounder ½ second On and ½ second Off
- Turn on the supervisory relay (SK-4 only)

4.4.4 System Supervisory Restoral Response

When the supervisory condition has been cleared, the control panel will perform the following:

- Turn off the FACP Zone Supervisory LED
- Turn off the piezo sounder
- Turn off the supervisory relay (SK-4 only)

4.4.5 Trouble Condition Response

The control panel, upon detection of one or more trouble conditions, will perform the following:

- Blink the FACP System Trouble LED one second On and one second Off
- Blink the FACP Zone Trouble LED one second On and one second Off
- Turn on remote annunciator Trouble LED and pulse the piezo sounder
- Pulse the FACP piezo sounder one second On and one second Off
- Transfer fail-safe Trouble relay
- Additional LEDs will turn on or blink according to the specific trouble
 - ✓ NAC Disable LED if NAC has been disabled
 - ✓ Zone Disable LED if a zone has been disabled
 - ✓ NAC Fault LED if a fault is detected on an NAC
 - ✓ Power Trouble LED if an AC, battery or charger fault is detected
 - ✓ AC Power LED will turn off if AC fail or brownout occurs
 - ✓ Alarm Silence LED if Silence button is pressed after an alarm or trouble
 - ✓ Walktest LED if Walktest mode is entered
 - ✓ Zone Maintenance LED if a I³ smoke detector needs servicing
 - ✓ Earth Fault LED if a ground fault occurs (zero impedance to ground)
 - ✓ Battery Fault LED if low or no battery condition occurs
 - ✓ Charger Fault LED if a charger trouble occurs

4.4.6 Trouble Condition Restoral

The control panel performs the following upon restoral of all trouble conditions:

- Turn off the FACP System Trouble LED
- Turn off the FACP Zone Trouble LED
- Turn off the remote annunciator Trouble LED and piezo sounder
- Turn off the piezo sounder
- Transfer the fail-safe Trouble relay
- Turn off additional LEDs corresponding to specific troubles

SECTION 5 Power Supply Calculations

5.1 Overview

This section contains instructions and tables for calculating power supply currents in alarm and standby conditions. This is a four-step process, consisting of the following:

1. Calculating the total amount of AC branch circuit current required to operate the system
2. Calculating the power supply load current for non-fire and fire alarm conditions and calculating the secondary (battery) load
3. Calculating the size of batteries required to support the system if an AC power loss occurs
4. Selecting the proper batteries for your system

5.2 Calculating the AC Branch Circuit

The control panel requires connection to a separate, dedicated AC branch circuit, which must be labeled **FIRE ALARM**. This branch circuit must connect to the line side of the main power feed of the protected premises. No other non-fire alarm equipment may be powered from the fire alarm branch circuit. The branch circuit wire must run continuously, without any disconnect devices, from the power source to the control panel. Overcurrent protection for this circuit must comply with Article 760 of the National Electrical Codes as well as local codes. Use 14 AWG (2.00 mm²) wire with 600 volt insulation for this branch circuit.

Use Table 5-1 , to determine the total amount of current, in AC amperes (A), that must be supplied to the system.

TABLE 5-1:120 VAC Branch Circuit Requirements

Device Type	Number of Devices		Current Draw (AC amps)		Total Current per Device
SK-2/SK-4 or SK-2E/SK-4E	1	X	2.3	=	
	[]	X	1.15	=	
	[]	X	[]	=	
Sum Column for AC Branch Current Required				=	

5.3 Calculating the System Current Draw

5.3.1 Overview

The control panel must be able to power all internal and external devices continuously during the non-fire alarm condition. To calculate the non-fire alarm load on the system power supply when primary power is applied, use Calculation Column 1 in Table 5-3 on page 46. The control panel must support a larger load current during a fire alarm condition. To calculate the fire alarm load on the power supply, use Calculation Column 2 in Table 5-3 on page 46. The secondary power source (batteries) must be able to power the system during a primary power loss. To calculate the non-fire alarm load on the secondary power source, use Calculation Column 3 in Table 5-3 on page 46.

When calculating current draw and the battery size, note the following:

- ‘Primary’ refers to the main power source for the control panel
- ‘Secondary’ refers to the control panel’s backup batteries
- All currents are given in amperes (A). Table 5-2 shows how to convert milliamperes and microamperes to full amperes.

TABLE 5-2: Converting to Full Amperes

To convert...	Multiply	Example
Milliamperes (mA) to amperes (A)	$\text{mA} \times 0.001$	$3 \text{ mA} \times 0.001 = 0.003\text{A}$
Microamperes (μA) to amperes (A)	$\mu\text{A} \times 0.000001$	$300 \mu\text{A} \times 0.000001 = 0.0003 \text{ A}$

5.3.2 How to Use Table 5-3 on page 46 to Calculate System Current Draw

Use Table 5-3 on page 46 to calculate current draws as follows:

1. Enter the quantity of devices in all three columns
2. Enter the current draw where required. Refer to the SilentKnight Device Compatibility Document for compatible devices and their current draw
3. Calculate the current draws for each in all columns
4. Sum the total current for each column
5. Copy the totals from Column 2 and Column 3 to Table 5-4 on page 47

Following are the types of current that can be entered into Table 5-3 on page 46:

- ✓ **Calculation Column 1** - The primary supply current load that the control panel must support during a non-fire alarm condition, with AC power applied.
- ✓ **Calculation Column 2** - The primary supply current load that the control panel must support during a fire alarm condition, with AC power applied.
- ✓ **Calculation Column 3** - The standby current drawn from the batteries in a non-fire alarm condition during a loss of AC power.

Table 5-3 contains three columns for calculating current draws. For each column, calculate the current and enter the total (in amperes) in the bottom row. When finished, copy the totals from Calculation Column 2 and Calculation Column 3 to Table 5-4 on page 47.

TABLE 5-3: System Current Draw Calculations

Device Type	Calculation Column 1 Primary, Non-Fire Alarm Current (amps)			Calculation Column 2 Primary, Fire Alarm Current (amps)			Calculation Column 3 Secondary, Non-Fire Alarm Current (amps)		
	Qty	X[current draw]=	Total	Qty	X [current draw] =	Total	Qty	X[current draw]=	Total
Main Circuit Board SK-2 or SK-4	1	X[0.080]= X[0.085]=	0.	1	X[0.112] ¹ = X[0.175] ¹ =	0.	1	X[0.080]= X[0.085]=	0.
SK-CAC4	[]	X[0.001]=		[]	X[0.001]=			X[0.001]=	
SK-4XTM	[]	X[0.005]=		[]	X[0.011] ¹ =			X[0.005]=	
SK-4XZM	[]	X[0.004]=		[]	X[0.008]=			X[0.004]=	
SK-4XLM/SK-RZA4 pair	[] 1 pair max.	X[0.004]=		[]	X[0.019]=			X[0.004]=	
2-wire Detector Heads	[]	X[] ² =		[]	X[]=			X[]=	
4-wire Detector Heads	[]	X[] ³ =		[]	X[]=			X[]=	
Power Supervision Relays ⁴	[]	X[0.025]=		[]	X[0.025]=			X[0.025]=	
NAC #1 ⁵				[]	X[]=				
NAC #2				[]	X[]=				
Current Draw from TB1 (nonalarm ⁶)		[]=			[]=			[]=	
Sum each column⁷ for totals		Primary Non-Alarm =			Primary Alarm =			Secondary Alarm =	

Table Footnote

1. If using the Reverse Polarity Alarm output, add 0.005 amps; if using the Reverse Polarity Trouble output, add another 0.005 amps.
2. Refer to the Device Compatibility Document for standby current.
3. Refer to the Device Compatibility Document for standby current.
4. Must use compatible listed Power Supervision Relay.
5. Current limitation of Terminal TB2 circuits is 2.50 amps per NAC (SK-4 requires optional transformer for max. current)
6. The total standby current must include both the resettable (TB1 Terminals 3 & 4) and nonresettable for SK-4 only (TB1 Terminals 1 & 2) power. Caution must be taken to ensure that current drawn from these outputs during alarm does not exceed maximum ratings specified. Current limitations of TB1, Terminals 1 & 2 = 0.500 amps, filtered, 24 VDC +/-5%, 120 Hz ripple @ 10 mV_{RMS}, nonresettable power and TB1, Terminals 3 & 4 = 0.500 amps, filtered, 24 VDC +/-5%, 120 Hz ripple @ 10mV_{RMS}, resettable power.
7. Total current draw listed above cannot exceed 3.0 amps with only standard transformer installed or, for the SK-4, 6.0 amps with both the standard and optional transformers installed.

5.4 Calculating the Battery Size

Use Table 5-4 to calculate the total Standby and Alarm load in ampere hours (AH). This total load determines the battery size (in AH), required to support the control panel under the loss of AC power. Complete Table 5-4 as follows:

1. Enter the totals from Table 5-3 on page 46, Calculation Columns 2 and 3 where shown
2. Enter the NFPA Standby and Alarm times (refer to ‘NFPA Requirements’ below)
3. Calculate the ampere hours for Standby and Alarm, then sum the Standby and Alarm ampere hours
4. Multiply the sum by the derating factor of 1.2 to calculate the proper battery size (in AH)
5. Write the ampere hour requirements on the Protected Premises label located inside the cabinet door

TABLE 5-4: Total Secondary Power Requirements at 24 VDC

Secondary Standby Load (total from Table 5-3 Calculation Column 3) []	Required Standby Time (24 or 60 hours) X[]	= AH
Primary Alarm Load (total from Table 5-3 Calculation Column 2) []	Required Alarm Time (for 5 min., enter 0.084, for 10 min., enter 0.168) X[]	= AH
Sum of Standby and Alarm Ampere Hours		= AH
Multiply by the Derating Factor		X 1.2
Battery Size, Total Ampere Hours Required		= AH

5.4.1 NFPA Battery Requirements

- NFPA 72 Local, Central and Proprietary Fire Alarm Systems require 24 hours of standby power followed by 5 minutes in alarm
- NFPA 72 Auxiliary and Remote Station require 60 hours of standby followed by 5 minutes in alarm. Batteries installed in a system powered by a generator need to provide at least 4 hours of standby power

5.4.2 Selecting and Locating Batteries

Select batteries that meet or exceed the total ampere hours calculated in Table 5-4 . The control panel can charge batteries in the 7 AH to 18 AH range. The control panel cabinet is capable of housing batteries up to 7 AH. Batteries larger than 7 AH require the RBB or other UL listed external battery cabinet.

Notes

Index

Numerics

2 Zone Main Circuit Board 8

4 Zone Main Circuit Board 9

A

AC power 19

AC Power LED 40

AC power rating 12

AC power requirements 44

AC trouble delay 34

accessories 15

ACK

see also Acknowledge 11

Acknowledge 11, 13

Acknowledge button 38

alarm

piezo pulse rate 14

alarm relay 8, 9, 10, 14, 23

contact rating 12

Alarm Silence 11, 13

Alarm Silence LED 40

alarm verification 35, 36

timing graph 35

annunciator, remote

see also SK-RZA4 30

applications 10

audible Walktest 39

autoresettable supervisory 34

auto-silence 34

auxiliary power 23

B

backbox

dimensions 14, 17

mounting 17

battery 14, 19

precautions 19

rating 12

battery box 16

mounting 18

battery calculations 47

battery connector 8, 9

Battery Fault LED 41

buttons 13

see also control buttons 11

C

cabinet

dimensions 17, 18

mounting 17

see also backbox 14

charger 14

charger capacity 12

Charger Fault LED 41

circuits 10

Class A 15, 20, 26

Class A Converter Module 9, 15

installation 25

Class B 10, 12, 14, 20

coding

NACs 34

combination circuit 10, 21

see also waterflow/tamper 34

combination waterflow/supervisory 10, 20, 21

requirements 21

wiring 21

compatibility

see also device compatibility 10

control buttons 11

controls 13

current

maximum system 12

nonresettable power 23

resettable power 23

see also system current 10

total output 22

current requirements for system 45, 46

D

description 10

device compatibility 10

dimensions

backbox 14, 17

DIP switch options

see also programming 31

DIP switch settings 32

see also programming 31

disable

see also zone enable/disable 11

disable NAC 36

dress panel 10, 15

E

Earth Fault LED 41

earth ground 19

enable

see also zone enable/disable 11

End-of-Line resistor

IDC 12, 20, 21

NAC 12, 22

F

fail-safe

trouble relay 23

fail-safe relay

see also trouble relay 14

features 10

fire alarm response 42

fire alarm restoral 42

Form-C 15, 29

see also relay 10, 14

freeze 20

freeze signal

see also smoke detector monitoring 10

G

Gentex synchronization 37

Ground Fault

disable 8, 9

ground fault 20, 41, 43

Index

I

- I3 detectors 14, 20
- IDC 9, 10, 12, 14, 20
 - alarm current 12
 - compatibility 20
 - End-of_Line resistor 21
 - End-of-Line resistor 12, 20
 - maximum loop resistance 12, 20
 - see also Initiating Device Circuit 8
 - short circuit current 12
 - standby current 12
 - wiring 20
- indicators 13
 - see also LED 11
- Initiating Device Circuit 8, 9, 10, 12, 14, 20
 - Class A 26
- In-Line resistor
 - IDC combination circuit 21
- installation 17
 - Class A Converter Module 25
 - option modules 25, 27
 - SK-4XLM 27
 - SK-4XTM 27, 28
 - SK-4XZM 27
 - SK-CAC4 25

J

- J3 and J5
 - option module connectors 27
- J4 and J6
 - option module connectors 27
- JP1 jumper
 - placement supervision 27
- JP2
 - placement supervision 27

L

- Lamp Test 38
- LED 11, 13
 - AC Power 11, 13, 40
 - Alarm Silence 11, 13
 - alarm silence 40
 - Battery Fault 11, 13
 - battery fault 41
 - Charger 11, 13
 - charger fault 41
 - Earth Fault 11, 13
 - earth fault 41
 - Fire Alarm 11, 13
 - main circuit board 8, 9
 - Maintenance 11, 13
 - NAC Disable 11, 13
 - NAC disable 40
 - NAC Fault 11, 13
 - NAC fault 40
 - Power Trouble 11, 13
 - power trouble 40
 - Supervisory 11, 13
 - System Trouble 11, 13

- system trouble 40
- Trouble 11, 13
- Walktest 11, 13
- walktest 40
- Zone Disable 11, 13
- zone disable 40
- zone fire alarm 40
- zone maintenance 41
- zone supervisory 41
- zone trouble 41

- LED Interface Module 15
 - installation 27
 - see also SK-4XLM 30

M

- main circuit board
 - see also 2 Zone 8
 - see also 4 Zone 9
- maintenance 20
 - piezo pulse rate 14
- maintenance signal
 - see also smoke detector monitoring 10
- modes of operation
 - see also normal and walktest 38
- mounting
 - cabinet 17
- municipal box 28
- municipal box transmitter
 - see also SK-4XTM 15

N

- NAC 9, 10, 12, 14, 22
 - coding 34
 - current 22
 - disable 36
 - End-of-Line resistor 12, 22
 - maximum current 12
 - nonsilenceable 36
 - see also Notification Appliance Circuit 8
 - wiring 22
- NAC Disable LED 40
- NAC Fault LED 40
- nonpower-limited wiring 24
- nonresettable power 9, 10, 12, 14, 23
 - current 23
 - maximum current 12
- nonsilenceable NAC 36
- normal mode 38
- Notification Appliance Circuit 8, 9, 10, 12, 14, 22
 - Class A 26

O

- operating instructions 38
- operation 41
- option modules 15
 - connector 8, 9
 - connectors 27
 - installation 25, 27
 - placement supervision 27

Index

P

- piezo 14
 - alarm 14
 - maintenance 14
 - see also sounder 11
 - supervisory 14
 - trouble 14
- polarity reversal circuit
 - see also SK-4XTM 28
- power 12, 19, 23
 - maximum system 12
 - primary 19
 - secondary
 - see also battery 19
 - see also resettable and nonresettable power 9
- power supply calculations 44
- Power Trouble LED 40
- power-limited wiring 24
- programming 31, 32
 - chart 32
 - DIP switches 31
 - feature chart 32
 - supervisory 35
- programming DIP switches 31

R

- RBB 18
 - see also battery box 16
- relay 8, 9, 10, 14, 15, 23, 29
 - contact rating 12, 23
- Remote Annunciator
 - see also SK-RZA4 15
- remote station service 28
- Reset 11
- Reset button 38
- resettable power 8, 9, 10, 12, 14, 23
 - current 23
 - maximum current 12
- reverse polarity circuit
 - see also SK-4XTM 15

S

- selective silence 34
- silence
 - selective 34
- Silence button 38
- silence inhibit 34
- silent walktest 40
- SK-4XLM
 - installation 27, 30
 - see also LED Interface Module 15
 - see also LED interface module 30
 - specifications 30
 - wiring to SK-RZA4 30
- SK-4XTM 27
 - installation 27, 28
 - operation 28
 - see also Transmitter Module 15
 - see also transmitter module 28

- specifications 28
 - SK-4XZM
 - installation 27, 29
 - see also Zone Relay Module 15
 - see also zone relay module 29
 - specifications 29
 - SK-CAC4 20
 - installation 25
 - see also Class A Converter Module 9, 15
 - SK-RZA4
 - see also Remote Annunciator 15
 - see also remote annunciator 30
 - wiring to SK-4XLM 30
 - sounder 11, 14
 - status LEDs 40
 - strobe synchronization
 - see also synchronization 37
 - strobes
 - maximum quantity 37
 - Style B 12, 14, 20
 - see also Class B 10
 - Style D 15, 20, 26
 - Style Y 12, 14
 - see also Class B 10
 - Style Z 15, 26
 - supervision
 - option module placement 27
 - supervisory
 - piezo pulse rate 14
 - see also programming supervisory 35, 36
 - supervisory relay 9, 10, 14, 23
 - contact rating 12
 - supervisory response 42
 - supervisory restoral 42
 - switch functions 38
 - synchronization
 - Gentex 37
 - see also strobe synchronization 37
 - System Sensor 37
 - Wheelock 37
 - system current 10
 - system current calculations 45
 - System Sensor synchronization 37
 - System Trouble LED 40
- ## T
- temporal coding 34
 - transformer assembly 14
 - rating 14
 - Transmitter Module 15
 - transmitter module
 - see also SK-4XTM 28
 - trouble
 - piezo pulse rate 14
 - trouble relay 8, 9, 10, 14, 23
 - contact rating 12
 - fail-safe 23
 - trouble reminder 34

Index

trouble response 43

trouble restoral 43

U

UL

wiring requirements 24

V

verification

alarm timing graph 35

see also alarm verification 35

W

Walktest 11, 13

Walktest LED 40

Walktest Mode 38

Walktest mode 39

audible 39

exiting 40

silent 40

waterflow/tamper circuit 34

Wheelock synchronization 37

wiring

Class A Converter Module 26

Class A IDC 26

Class A NAC 26

combination waterflow/supervisory 21

IDC 20

NAC 22

nonpower-limited 24

power-limited 24

SK-CAC4 26

UL requirements 24

Z

Zone 1 20

Zone Disable LED 40

Zone Enable/Disable 11, 13

Zone Fire Alarm LED 40

Zone Maintenance LED 41

zone relay module 15

see also SK-4XZM 29

Zone Supervisory LED 41

Zone Trouble LED 41

Notes

Silent Knight Fire Product Warranty and Return Policy

General Terms and Conditions

- All new fire products manufactured by Silent Knight have a limited warranty period of 18 months from the date of manufacture against defects in materials and workmanship. See limited warranty statement for details.
- This limited warranty does not apply to those products that are damaged due to misuse, abuse, negligence, exposure to adverse environmental conditions, or have been modified in any manner whatsoever.

Repair and RA Procedure

- All products that are returned to Silent Knight for credit or repair require a RA (Return Authorization) number. Call Silent Knight Customer Service at 800-446-6444 or 763-493-6435 between 8:00 A.M. and 4:45 P.M. CST, Monday through Friday to obtain a return authorization number. Silent Knight Technical Support is available at 800-328-0103 between 8:00 A.M. and 6:00 P.M. CST, Monday through Friday.
- RA number must be prominently displayed on the outside of the shipping box. See return address example under Advanced Replacement Policy.
- Include a packing slip that has the RA number, a content list, and a detailed description of the problem should be included with each return.
- All products returned to Silent Knight must be sent freight pre-paid. After product is processed, Silent Knight will pay for shipping product back to customer via UPS ground.
- Return the Silent Knight product circuit board only. Products that are returned in cabinets will be charged an additional \$50 to cover the extra shipping and handling costs over board only returns. **Do not return batteries.** Silent Knight has the authority to determine if a product is repairable. Products that are deemed un-repairable will be returned to the customer.
- Product that is returned that has a board date code more than 18 months from date of manufacture will be repaired and the customer will be assessed the standard Silent Knight repair charge for that model.

Advanced Replacement Policy

- Silent Knight offers an option of advance replacement for fire product printed circuit boards that fail during the first 6 months of the warranty period.
- For advance replacement of a defective board contact your local Silent Knight Distributor or call Silent Knight at 800-446-6444 or 763-493-6435 to obtain a RA (Return Authorization) number and request advanced replacement.
- Customers without a Silent Knight account must use a MasterCard, Visa, or American Express credit card to get an advance replacement.

- A new or refurbished board will be shipped to the customer. The customer will initially be billed for the replacement board but a credit will be issued after the repairable board is received at Silent Knight. All returned products must comply with the guidelines described under “General Terms and Conditions”.
- The defective board must be returned within 30 days of shipment of replacement board for customer to receive credit. No credit will be issued if the returned board was damaged due to misuse or abuse.
- Repairs and returns should be sent to:

Silent Knight

Attn: Repair Department

7550 Meridian Circle Suite 100

Maple Grove, MN 55369-4927

RA Number: _____

Limited Warranty

Silent Knight warrants that the products of its manufacture shall be free from defects in materials or workmanship for 18 months from the manufacturing date code on the printed circuit board, if such goods have been properly installed, are subject to normal proper use, and have not been modified in any manner whatsoever. Upon return of the defective product, Silent Knight will at its sole discretion, either repair or replace, at no cost, such goods as may be of defective material or workmanship. Customers outside the United States are to return products to their distributor for repair.

Silent Knight SHALL NOT UNDER ANY CIRCUMSTANCES BE LIABLE FOR ANY INCIDENTAL OR CONSEQUENTIAL DAMAGES ARISING FROM LOSS OF PROPERTY OR OTHER DAMAGE OR LOSSES OWING TO THE FAILURE OF Silent Knight PRODUCTS BEYOND THE COST OF REPAIR OR REPLACEMENT OF ANY DEFECTIVE PRODUCTS.

Silent Knight MAKES NO WARRANTY OF FITNESS OR MERCHANTABILITY AND NO OTHER WARRANTY, ORAL OR WRITTEN, EXPRESS OR IMPLIED, BEYOND THE 18 MONTH WARRANTY EXPRESSLY SPECIFIED HEREIN.



**SILENT
KNIGHT**

by Honeywell

7550 Meridian Circle
Maple Grove, MN 55369-4927
763-493-6455
1-800-328-0103
Fax: 763-493-6475

© 2005 Silent Knight