

PIR1680 PASSIVE INFRARED SENSOR • INSTALLATION INSTRUCTIONS

SPECIFICATIONS

Coverage (l x w): 50ft x 50ft (15.2m x 15.2m) at 20°C (68°F), typical (with High Sensitivity Jumper "SEN" installed)
30ft x 35ft (9.1m x 10.6m) at 20°C (68°F), typical (with Normal Sensitivity)

Operating Temperature: -10° to +50°C (14°F to 122°F)

Mounting: Wall or corner, 12ft (3.6m) max.

Alarm Output: Normally-Closed Form-A Relay (Form C Option)

Contact Ratings: 100mA, 24VDC with internal 10Ω current-limiting resistor

Trouble Output: Active Low Open Collector Transistor Drive with 47Ω limiting resistor (100mA. max.)

Output Time: Continuous for high or low temp. signaling, momentary (3 sec.) for self diagnostics failure

High Temperature Set Point: 90°F +/- 4°F

Low Temperature Set Point: 40°F +/- 4°

POWER-SUPPLY REQUIREMENTS

Note: This unit is intended for operation from a power source that provides a 4 hour battery backup in the event of a power failure.

Filtered DC: 10.6 to 16VDC nominal with battery backup from control panel.

Current Drain: 28mA (idle or alarm) at 12VDC (nominal) 33mA (idle or alarm) at 16VDC (nominal) 44mA (trouble condition) at 16VDC (nominal)

PHYSICAL

Dimensions: 3.3in x 2.5in x 1.9in (8.4cm x 6.4cm x 4.8cm) (HxWxD)

Shipping Weight: 5oz (142g)

FEATURES

- Advanced Microprocessor-based circuitry
- Utilizes Analog to Digital Signal Conversion
- Unique Passive Adaptive Algorithm optimizes detection
- Exclusive Detect & Compare Imaging Diagnostics D.C.I.D.
- True Room Temperature Measurement provides accurate sensitivity and Room-Temp Alert Features
- Selectable sensitivity
- 40 Element Stacked Array Lens eliminates detection hot spots
- Look Down/Creep Zones provides coverage beneath sensor
- Small Pet and Rodent Immunity (20 lbs. max.)
- Active Self Testing, signals panel if unit fails internal diagnostics
- Dual Mode Multifunction Trouble Output (Temp Alert-Self Test)
- Low Temperature Alert for Heating System Monitoring (a Patented Feature) signals panel if temperature drops below 40°F in the premises
- High Temperature Alert for Cooling System Monitoring (a Patented Feature) signals panel if temperature rises above 90°F in the premises
- Power input filtering provides protection against transients
- Unique circuit design protects against false alarms due to radio-frequency interference
- Vertical and horizontal aiming capabilities
- Small size with ample wiring space
- Flat or Corner mountable to 12ft.
- Swivel bracket for ceiling or wall mounting above 12ft. (SVL2)
- Bug Shield

LOCATING THE DETECTOR & SELECTING A LENS

First, choose the type of coverage that will be best for the particular area you need to protect.

Standard Wide-Angle Lens

Corner mounting with this lens is preferred as it provides the best overall coverage. Choose a corner where the path of an intruder will most likely cross beams, as opposed to walking towards or away from them. This lens is intentionally made with an 85 degree angle of view, to help prevent curtains on windows from being in detection zones. Sources of heat, such as radiators and space heaters, do not usually pose a problem as long as hot air from them does not blow directly onto the detector. One exception to this is overhead radiant heaters, these produce very high levels of infrared energy and can heat the unit at some distance. Mount the unit as far from these as possible. Do not mount the unit where the sun can shine directly on it. Mount it away from the direction of sunlight.

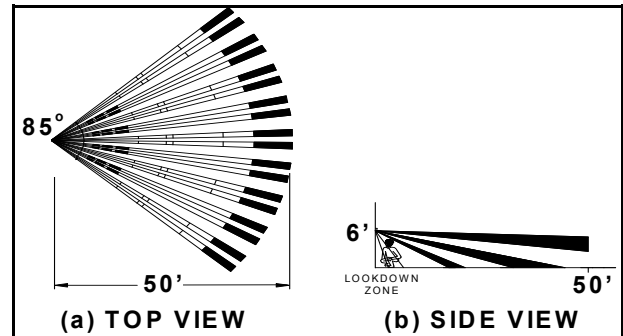

Standard Wide-Angle Lens (LENS109) Coverage Pattern

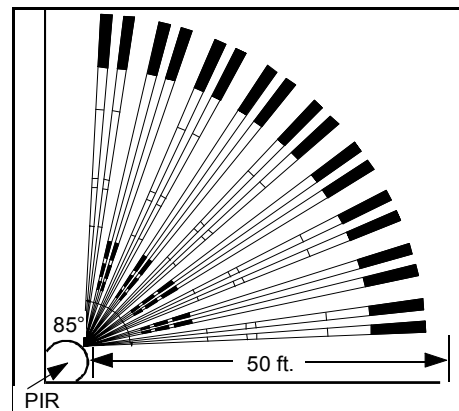

Top View: Standard Wide Angle Lens (LENS109) corner mounted



Napco Security Systems, Inc.
333 Bayview Avenue, Amityville, New York 11701
For Sales and Repairs, (800) 645-9445
For Technical Service, (800) 645-9440

WI884E 3/2000

If you are protecting a typical room area which may include small

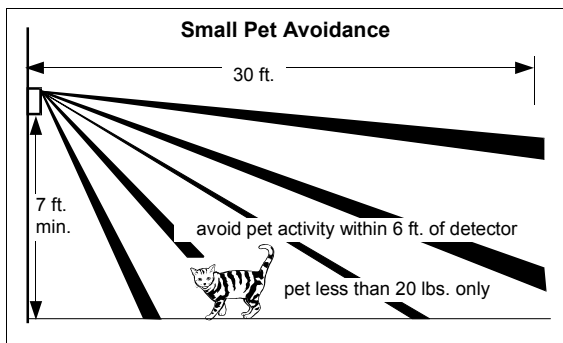

Side View: Standard Lens (LENS100) used for small pets

possible (7 ft. minimum) and avoid placement that would allow the pets to get within 6 ft. of the detector. It may be necessary to mask a zone with the supplied material if a staircase is close to the detector and directly in a zone. It is also possible to adjust beams laterally by sliding the lens and retainer horizontally within its stops.

Pet-Alley Lens (LENS817)

For larger pets use a Pet-Alley Lens (LENS817). This lens provides the same pattern and coverage as the standard Wide-Angle lens, but there are no lower zones. This creates an unprotected "Pet Alley" in which a larger pet can freely move about. The detector should be mounted at 5 to 6 ft. with the board mounting height index set to 6 ft.

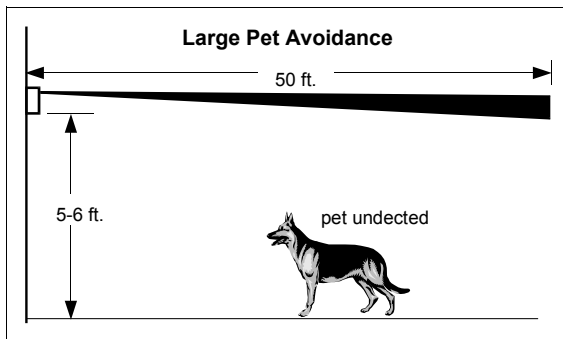

Side View: Pet-Alley Lens (LENS817) used for larger pets

Barrier Lens (LENS818)

For hallways, aisles or corridors use the Barrier lens, sometimes referred to as a curtain lens (LENS818), will provide the best solution. This lens stacks the elements to form an efficient and effective wall that will detect anyone crossing it while ignoring motion on either side of the detector. The detector has a maximum range of 50 ft. with this lens.

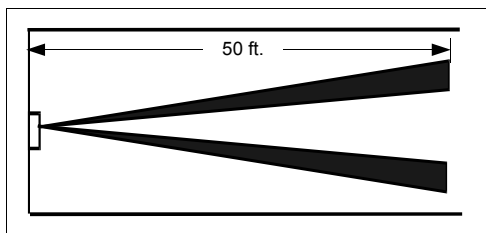

Top View: Barrier Lens (LENS818) used for hallways

Long Range Lens (LENS840)

For longer range coverage the Long Range Lens (LENS840) will provide up to 100 ft. of range with a single pair of beams. Complete coverage pattern is included with the lens.

MOUNTING

First, use a screw driver to carefully lift the lens cover from the housing. Second, remove the circuit board from the housing by removing the screw in the center of the board. **Note:** the screw is

attached to the circuit board and will not separate when removed. Third, determine the wire entry points on the housing. The housing provides four possible wire entry points, two for surface wiring and two for hidden wiring. Determine which entry is most convenient and punch out or remove the thin plastic section. Fourth, mount the housing to the wall. There are three mounting options to choose from depending on the desired location: flat wall mounting, corner mounting or using the swivel bracket (SVL2) for ceiling and wall mounting where it is advantageous to tilt or aim the unit along a wall. **Note:** using two units on swivel brackets mounted side by side it is possible to cover almost 180 degrees when mounted on a flat wall. If using the swivel bracket refer to the instructions with the bracket. For wall or corner mounting simply hold the case in the desired location and using the supplied screws push through the appropriate thin wall mounting screw holes and attach the unit with two or four screws. **Note:** Do not over tighten the screws as this can distort the case and compromise the air seal of the unit, because not all walls are flat and all corners are square. Reinstall the circuit board and proceed to wire the detector.

WIRING & TERMINAL DESCRIPTIONS

Refer to the wiring diagram and terminal descriptions, connect the appropriate wire to the corresponding terminal. When you have finished wiring the terminals seal the opening around the wire entry hole and any other unused holes with the supplied sealer.

Power (Terminals 1 [+] & 2 [-]): Connect 12 volts regulated or unregulated power.

N.C. (Terminals 3 & 4) Normally closed alarm relay: Connect to zone wiring, either detection of an intruder or loss of power will cause relay to open.

TRBL (Terminal 5) Active low (open collector transistor) auxiliary output , can be configured to provide an activation on high temperature, low temperature or self test failure. Using the

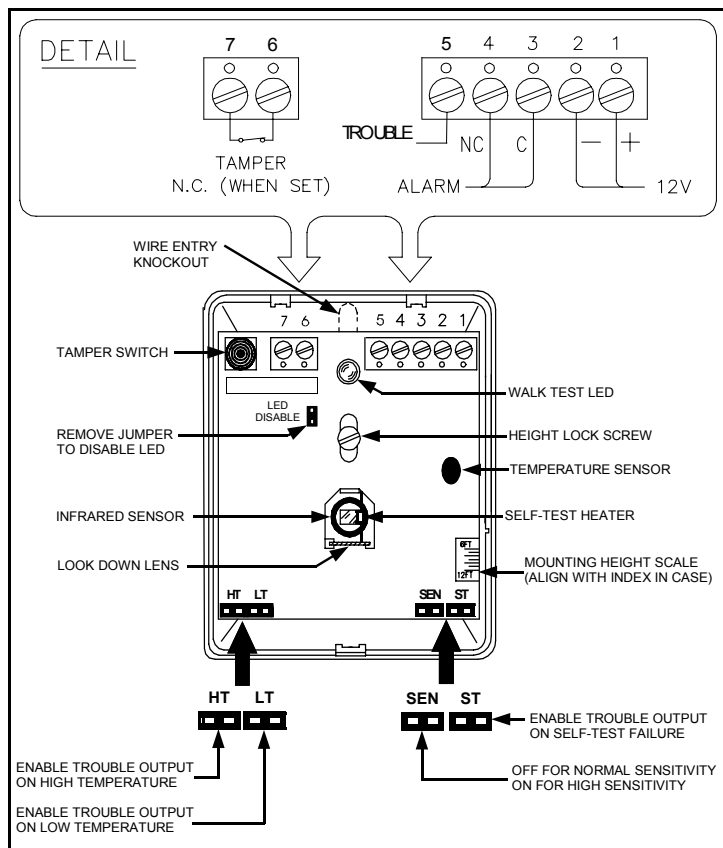

PIR1680 Circuit Board Detail

appropriate jumper settings this output can activate on any combination of the the above items including all or none.

Tamper (Terminals 6 & 7): With lens cover in place, the contacts are closed. When lens cover is removed, the contacts are opened. Typically, these are wired to a 24 hour tamper circuit.

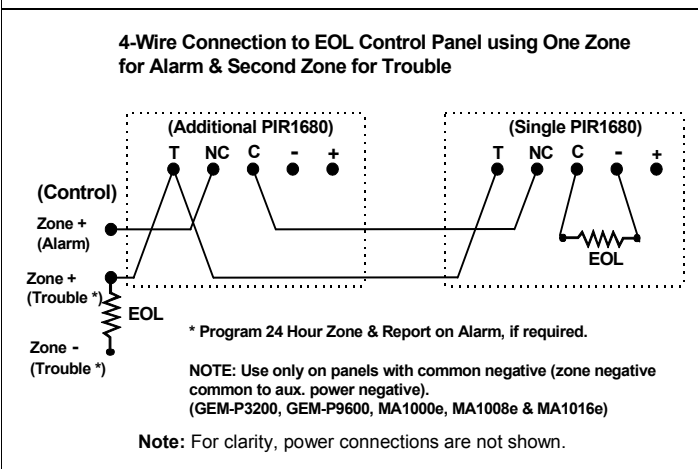
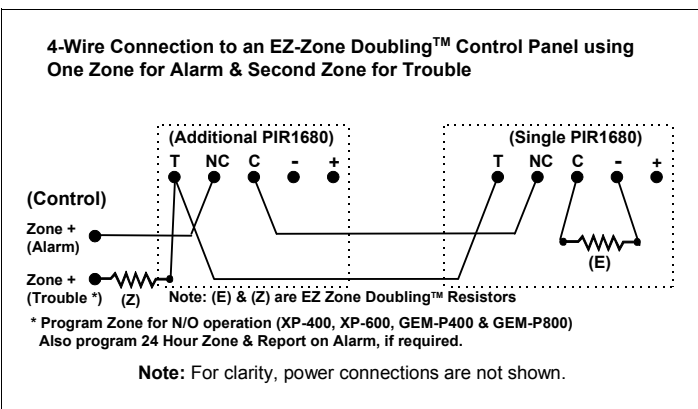

CONFIGURING THE PIR1680

Low Temperature Alarm for Heating System Monitoring (a Patented Feature)

The PIR1680 has the ability to activate a Low Temperature Output in the case of the ambient temperature falling below 40°F. *This feature functions exactly the same as if you had purchased a separate temperature switch.* To enable this feature, connect a jumper across pins LT and wire the Trouble Output (terminal 5) into the positive terminal of a zone programmed for 24 Hour protection. This output signal will remain active for as long as the temperature remains below 40°F, when the temperature rises several degrees above this the output will reset .

High Temperature Alarm for Cooling System Monitoring (a Patented Feature)

The PIR1680 has the ability to activate a High Temperature Output in the case of the ambient temperature rises above 90°F. *This feature functions exactly the same as if you had purchased a separate temperature switch.* To enable this feature, connect a jumper across pins HT and wire the Trouble Output (terminal 5) into the positive terminal of a zone programmed for 24 Hour protection. This output signal will remain active for as long as the temperature remains above 90°F, when the temperature falls several degrees below this the output will reset.

Note: If the unit is in a high or low temperature condition, the LED will glow dimly instead of being completely turned off , this can be used to test the units temperature monitoring feature. If it is

desired to test the temperature monitoring feature, it will be necessary to either trip the unit or wait several minutes for the unit to measure the temperature, because the room temperature is measured every 10 minutes or each time an alarm is tripped. You will need freeze spray or a freezer to test low temperature or to test high temperature a hairdryer will do. Heat or cool the temperature sensor (refer to Circuit Board Detail), then trip the unit, assuming it hasn't done that already and let it settle and observe the LED for a dim glow.

Self Test/Trouble Output

The PIR1680 will periodically test its circuitry to insure it is operating in the manner for which it was designed. Self Test failure will be indicated by the rapid blinking of the LED (do not confuse it with the unit's warm up period, in which it will also blink for approximately 60 seconds). To send a trouble output to the control panel on self test failure, install a jumper connector across pins ST and wire the Trouble Output (terminal 5) into the positive terminal of a zone programmed for 24 Hour protection. **Note:** This output is a 1 second momentary activation. This makes it possible to differentiate a temperature condition from a self test failure on the same zone. A temperature signal will not immediately be followed by a restore signal (the temperature must rise several degrees first). However, because the selftest failure activation is momentary the zone will report an open followed by a restoral. *Appropriate panel programming is required.*

LED Disable Jumper

To prevent the walk test LED from turning on, remove the jumper from the pins labeled LED DISABLE. Removing this jumper will not affect the flashing of the LED on self test failure or the dim glow during a high/low temperature condition.

Sensitivity Setting (SEN Jumper)

The unit is shipped with no jumper in this position. This is the normal sensitivity mode and is recommended for most installations whose coverage area does not exceed 30' x 35'. Coverage out to 50' x 50' is possible in this mode, but the intruder will have to cover a larger distance before detection. To have faster catch performance this jumper must be installed. **Note:** Advanced signal processing will be defeated in this high sensitivity mode. **DO NOT INSTALL THIS JUMPER IF PETS OR RODENTS ARE PRESENT.** If LENS818 (Barrier Lens) or LENS840 (Long Range Lens) is used, it is recommended that the SEN jumper be installed.

Vertical Aiming (refer to lens coverage pattern)

The height scale that is on the board is intended to make vertical aiming quick and easy. If the board is set to the same number as the height the unit is mounted at, the unit will be aimed for maximum coverage. However, if the unit is used for less than the maximum range, move the board up (towards 12 ft.) and walk test the unit. **Note:** If the wall upon which the unit is mounted is not vertical, move the board up or down and walk test the unit. If using the Long range or Barrier Lens, set the board to 12 feet on the height scale as a starting point as aiming accuracy for long range lenses can greatly affect performance.

Horizontal Aiming (refer to lens coverage pattern)

The lens may be moved left to right within its holder to help avoid problem areas. However, the most effective solution for a possible problem area is to block the zone, by applying a piece of lens foil (supplied) to the inside segment of the lens representing that zone.

Installations with Pets

The PIR1680 will provide good immunity to small pets in most applications. The pet or pets should be small (less than 20 lbs.). Several small cats are acceptable. If you have three or more large ones, we recommend that the NAPCO C200AP dual technology sensor be used. Mount the unit as high as possible. If the unit is

above a chair or other piece of furniture that the pet may climb onto, mask the look down beam. Make certain the sensitivity (SEN) jumper is off (normal sensitivity). If a stair case is in the field of view and closer than 20 ft. from the unit, it may be necessary to mask that beam.

REPLACING THE LENS

The lens is mounted behind a Lens Support insert that fits inside the front cover. To install one of the accessory lenses, proceed as follows:

1. Carefully lift the lens cover from the housing.
2. Remove the bug shield, which will expose the lens support assembly.
3. While pushing the lens in at the top, with fingers straddling the LED jewel, press down at the top of the Lens Support as shown until the support clears the three top retainers. Be careful not to dislodge the look down-lens window.

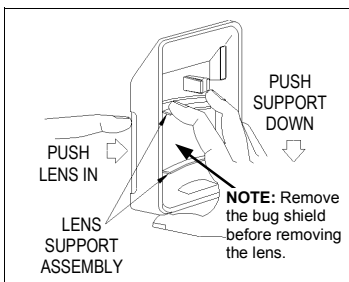

Replacing the lens

4. Push the Lens Support up until it clears the three bottom retainers and remove the assembly.
5. Slide out the lens.
6. Install the replacement lens with the grooved side in and the with the lens not in the up side down position. All lenses are

marked with with the word top stamped on the border, this may be difficult to see, so as a rule put the taller lens segments up.

7. Install the retainer assembly into the front cover. Slip the Lens Support behind the lower retainers, then push in at the top until the Lens Support snaps into place. Insert the bug shield and place the lens cover back into the housing.

COMPLETING THE INSTALLATION

Allow at least three minutes for the unit to stabilize after applying power, during this time the unit will perform its own self diagnostics and set a baseline detection level. The LED will flash rapidly for approximately 1 minute and not function until the unit is ready. If the unit was installed after being kept in a hot or cold vehicle allow the unit to operate with its cover in place for about 15 minutes. This will insure that the unit has measured the proper room temperature. Walk test the unit to insure the desired coverage, making any board height adjustments that may be necessary.

Note: One common cause of short range is having the lens in up side down, always check this! During walk test, the unit will go into a zone finding mode for 15 seconds after each trip. This will cause the LED to light each time a beam is entered. To view the normal detection pattern remain motionless for at least 15 seconds between walk tests.

NAPCO SECURITY LIMITED WARRANTY



NAPCO SECURITY SYSTEMS, INC. (NAPCO) warrants its products to be free from manufacturing defects in materials and workmanship for *thirty-six months* following the date of manufacture. NAPCO will, within said period, at its option, repair or replace any product failing to operate correctly without charge to the original purchaser or user.

This warranty shall not apply to any equipment, or any part thereof, which has been repaired by others, improperly installed, improperly used, abused, altered, damaged, subjected to acts of God, or on which any serial numbers have been altered, defaced or removed. Seller will not be responsible for any dismantling or reinstallation charges.

THERE ARE NO WARRANTIES, EXPRESS OR IMPLIED, WHICH EXTEND BEYOND THE DESCRIPTION ON THE FACE HEREOF. THERE IS NO EXPRESS OR IMPLIED WARRANTY OF MERCHANT ABILITY OR A WARRANTY OF FITNESS FOR A PARTICULAR PURPOSE. ADDITIONALLY, THIS WARRANTY IS IN LIEU OF ALL OTHER OBLIGATIONS OR LIABILITIES ON THE PART OF NAPCO.

Any action for breach of warranty, including but not limited to any implied warranty of merchant ability, must be brought within the six months following the end of the warranty period.

IN NO CASE SHALL NAPCO BE LIABLE TO ANYONE FOR ANY CONSEQUENTIAL OR INCIDENTAL DAMAGES FOR BREACH OF THIS OR ANY OTHER WARRANTY, EXPRESS OR IMPLIED, EVEN IF THE LOSS OR DAMAGE IS CAUSED BY THE SELLER'S OWN NEGLIGENCE OR FAULT.

In case of defect, contact the security professional who installed and maintains your security system. In order to exercise the warranty, the product must be returned by the security professional, shipping costs prepaid and insured to NAPCO. After repair or replacement, NAPCO assumes the cost of returning products under warranty. NAPCO shall have no obligation under this warranty, or otherwise, if the product has been repaired by others, improperly installed, improperly used, abused, altered, damaged, subjected to accident, nuisance, flood, fire or acts of God, or on which any serial numbers have been altered, defaced or removed. NAPCO will not be responsible for any dismantling, reassembly or reinstallation charges.

This warranty contains the entire warranty. It is the sole warranty and any prior agreements or representations, whether oral or written, are either merged herein or are expressly canceled. NAPCO neither assumes, nor authorizes any other person purporting to act on its behalf to modify, to change, or to assume for it, any other warranty or liability concerning its products. In no event shall NAPCO be liable for an amount in excess of NAPCO's original selling price of the product, for any loss or damage, whether direct, indirect, incidental, consequential, or otherwise arising out of any failure of the product. Seller's warranty, as herein above set forth, shall not be enlarged, diminished or affected by and no obligation or liability shall arise or grow out of Seller's rendering of technical advice or service in connection with Buyer's order of the goods furnished thereunder.

NAPCO RECOMMENDS THAT THE ENTIRE SYSTEM BE COMPLETELY TESTED WEEKLY.

Warning: Despite frequent testing, and due to, but not limited to, any or all of the following; criminal tampering, electrical or communications disruption, it is possible for the system to fail to perform as expected. NAPCO does not represent that the product/system may not be compromised or circumvented; or that the product or system will prevent any personal injury or property loss by burglary, robbery, fire or otherwise; nor that the product or system will in all cases provide adequate warning or protection. A properly installed and maintained alarm may only reduce risk of burglary, robbery, fire or otherwise but it is not insurance or a guarantee that these events will not occur. CONSEQUENTLY, SELLER SHALL HAVE NO LIABILITY FOR ANY PERSONAL INJURY, PROPERTY DAMAGE, OR OTHER LOSS BASED ON A CLAIM THE PRODUCT FAILED TO GIVE WARNING. Therefore, the installer should in turn advise the consumer to take any and all precautions for his or her safety including, but not limited to, fleeing the premises and calling police or fire department, in order to mitigate the possibilities of harm and/or damage.

NAPCO is not an insurer of either the property or safety of the user's family or employees, and limits its liability for any loss or damage including incidental or consequential damages to NAPCO's original selling price of the product regardless of the cause of such loss or damage.

Some states do not allow limitations on how long an implied warranty lasts or do not allow the exclusion or limitation of incidental or consequential damages, or differentiate in their treatment of limitations of liability for ordinary or gross negligence, so the above limitations or exclusions may not apply to you. This Warranty gives you specific legal rights and you may also have other rights which vary from state to state.