



333 Bayview Avenue  
Amityville, New York 11701

For Sales and Repairs, (800) 645-9445  
For Technical Service, (800) 645-9440

Publicly traded on NASDAQ Symbol: NSSC

# FREEDOM 64

## F-64TP-H Hardwired Touchpad and F-TAB INSTALLATION INSTRUCTIONS

© NAPCO 2007

WI1532A 1/07

### GENERAL DESCRIPTION

The NAPCO Freedom 64 Deadbolt-Activated Home Protection System, a revolutionary new concept in residential security, combines intuitive interactive arming with a passive disarming scheme, providing a system which is not only effortless to use, but also 100% **false alarm resistant** during the critical arming and disarming sequences.

The system is armed with a simple push of a button (**STAY** or **AWAY**) on the F-64TP-H Touchpad control module, followed by the locking of the home's deadbolt. To disarm, simply unlock the deadbolt.

The microprocessor controlled F-64TP-H Touchpad receives information regarding the status of the deadbolt and door through its F-TAB deadbolt sensor and an integral PIR sensor to ensure fool-proof operation. With the Touchpad's integrated voice prompt speaker and 2-line LCD window, interacting with the system is easy and trouble-free.

The F-TAB deadbolt sensor, which is installed in the deadbolt strike hole, senses the state of the deadbolt (locked or unlocked). The door status (open or closed) is supplied to the Touchpad via a magnetic door contact sensor (not provided) wired into it. The deadbolt and door contact information is sent to the Touchpad microprocessor and is used to arm and/or disarm the system. The Touchpad clearly displays the monitored door status ("Open", "Unlocked", etc.) in its LCD window. There are no moving parts in the F-TAB deadbolt sensor to break or wear out; its adaptive inductive system ensures trouble free use. If the position of the deadbolt in its strike hole changes over time due to the door sagging, deadbolt replacement, etc., the F-64TP-H Touchpad microprocessor will automatically account for, and make, the necessary adjustments for these changes.

The F-64TP-H Touchpad's integral wide-angle UL-approved PIR motion sensor acts as an occupancy sensor that provides the microprocessor with activity information which prevents the user from making errors during the critical exit and entry periods. For example, if the User presses the **AWAY** button, opens and closes the door and locks the deadbolt but does not leave, the PIR will sense the User's presence inside the home and *automatically* defaults to **STAY** mode arming, preventing a false alarm.

If the system is armed in the **AWAY** mode, the Touchpad PIR will generate an alarm if an intruder is detected. After an intruder has been detected, the system may only be silenced by inserting the I-FOB digital key into the I-FOB slot on the face of the Touchpad.

By allowing this level of system control without traditional numeric keypad interaction, the NAPCO Freedom System will provide a significant reduction in false alarms due to user error and also provide comfortable use of the system to those customers whose technophobic tendencies would prevent them from arming and disarming the system using a traditional keypad.

The NAPCO Freedom 64 System is also designed to pre-

vent the arming of the alarm system if all deadbolts are not engaged, a high security feature normally found only in very elaborate high-end installations.

The F-64TP-H Touchpad is one of 4 Touchpad designs within the NAPCO Freedom 64 Home Protection System. The three other Touchpad designs include:

- **F-64TP**: Wireless Touchpad (See WI1499)
- **F-64TPG\***: Garage Door Touchpad (See WI1508)
- **F-64TPBR**: Bedroom Touchpad (See WI1505)

### INTEGRAL 4 ZONE EZM

Each Touchpad contains an integral 4 zone EZM, allowing the zone capacity of the F-64 panel to be expanded. With a maximum of four Touchpads allowed per system, a total of 16 zones may be added to the system using Touchpads. Three GEM-K1CA keypads can also be added (each with an integral 4 zone EZM) adding 12 additional zones for a total of 28 zones from Touchpads and keypads. Additional GEM-EZM's and/or GEM-EZM4-8's can be added, thus maximizing the capacity of the F-64 control panel to a grand total of 64 zones within the system.

### INSTALLATION

The NAPCO Freedom System utilizes the home's existing deadbolts and requires only that the F-TAB deadbolt sensor be installed into the deadbolt strike hole in the door jamb. This sensor is compatible with all 3/4" diameter deadbolts with a 5/8" throw or greater. Simply remove the strike plate and dust cup, run the 2 conductor wire from the deadbolt hole to the adjacent Touchpad and insert the F-TAB deadbolt sensor into the strike hole. The Touchpad installs on a 4-wire bus and also includes an integral siren that produces 85dB (at 10 feet) as required for UL Residential Burglar and Fire. The Touchpad includes 2 on-

board zone inputs, one for the door contact and one for an auxiliary device such as a motion sensor, glass-break detector or other device.

In less time than it takes to install a traditional keypad, this comprehensive module consisting of the Touchpad, deadbolt sensor, door contact, motion sensor and siren can be installed.

**NOTE:** If protecting a door with glass panels or side lights, an acoustic glass-break sensor (connected to the Touchpad Aux. Zone) should be installed to insure the integrity of the system.

### POWER

The F-64TP-H Touchpad is powered by the keypad bus of the F-64 Control Panel. Each Touchpad draws 70mA (nominal) at 12VDC and 210mA in alarm. The standby current may be reduced by cutting jumper "W1". Deduct these values from the system standby current, as described in the wiring diagram.

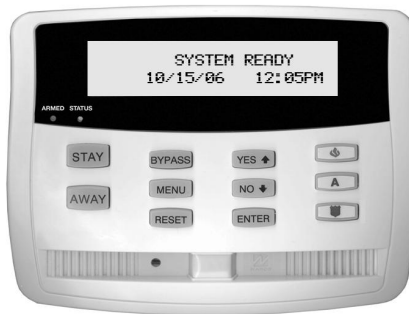

\*Not evaluated by UL.

This manual contains the Installation Instructions for the F-64TP-H Hardwired Touchpad and the F-TAB deadbolt sensor. It is intended to be used in conjunction with the F-64 Panel Installation Instructions (WI1501) and the F-64 Panel Programming Instructions (WI1502).

## SELECT SYSTEM CONFIGURATION

The first task is to determine where the Touchpad will likely be installed, and what kind of system configuration you will need:

- **Install a hardwired Touchpad without any transmitters** (continue with these instructions)
- **Install a wireless Touchpad with a Primary and/or a Secondary transmitter** (see W11499)

The factors considered when selecting the type of Touchpad are based primarily upon the installation environment, however the similarities and differences should be noted.

The wireless and the hardwired Touchpads both require direct wiring to the control panel and are equivalent in that they both provide the same protection and operate in the same manner. Although they both require the installation of the F-TAB deadbolt sensor and a door sensor, the hardwired system requires these sensors be wired directly to the hardwired Touchpad. The wireless system only requires the F-TAB and door sensor be wired directly to a *L-TRANS wireless transmitter*, thus providing more flexibility when selecting Touchpad mounting locations. The hardwired Touchpad requires that it be mounted adjacent to the primary exit/entry door. The wireless Touchpad can be mounted anywhere that allows the integral PIR to "protect" the door latch with its PIR, and allowing the user to hear the siren chirp when exiting and arming Away. The wireless Touchpad also allows for two doors to be protected with one Touchpad.

## INSTALLATION PROCEDURES

After installing the F-64 control panel, turn to page 5 and begin the procedures necessary for:

- Wiring and mounting the Touchpad
- Mounting and wiring the F-TAB sensor

After completing the procedures on page 7, return to this section to configure the other options necessary for each Touchpad installed in the system, as detailed in the next section **Configuring the Touchpad**, below.

### A. CONFIGURING THE TOUCHPAD

If not in already, enter **Touchpad Configuration Mode** by placing the F-64 panel jumper in Configuration Mode, the Touchpad LCD text will display "OUT OF SYSTEM" within a few seconds (you can also press and hold the **STAY**, **BYPASS** and **YES** buttons until the system reboots or wait for a 60 second timeout). Press and hold **MENU** for 2 seconds to enter Touchpad Configuration Mode.

Once the Touchpad Configuration Mode is accessed, all messages will display in the order shown below (press **MENU** to scroll through the list or press **RESET** to exit). For more complete information, see the F-64 panel programming instructions, W11502. :

- **KEYPAD BEEP**
- **ENTRY SOUNDER**
- **BACKLIGHT FOLLOW PIR**
- **BACKLIGHT BRIGHTNESS**
- **AMBUSH INTERVAL**
- **AMBUSH SOUNDER**
- **KEYPAD ADDRESS.**
- **EZM ADDRESS**
- **ZONE RESPONSE**

- **TAMPER DETECT**
- **DISABLE PIR**
- **PRE AWAY/STAY**

### B. EASY MENU DRIVEN PROGRAM MODE

Temporarily replace the F-64TP-H Touchpad addressed as "01" with an F-64PROG programmer, and program the panel using the *Easy Menu Driven Program Mode* (or use PCD-Windows Quickloader Download software). See programming instructions W11502 for complete details.

### C. CREATE THE MASTER I-FOB

**Note:** Only one Master I-FOB can exist within the system. The Master I-FOB is the first I-FOB enrolled in the system and is installed in User Slot 1. The Master I-FOB is used to enroll additional I-FOB's in all 4 Areas. The Master I-FOB should be given to the customer after installation.

To enroll a Master I-FOB on a **new** system:

1. Remove power from the system, wait 10 seconds, then power up the system.
2. Within one minute after power up, press **MENU** on the Touchpad to enter "Touchpad Menu Mode".
3. Press **MENU** repeatedly until the Touchpad reads "ACTIVATE PROGRAM Y/N". Press **YES** to enter the "User Program Mode".
4. Press **MENU** until the Touchpad reads "CREATE MASTER I-FOB Y/N". Press **YES**.
5. Insert the I-FOB with the red label that reads "IFOB MASTER SILENCE KEY" into the I-FOB keyhole located on the face of the Touchpad.
6. The Touchpad window will display, "MASTER ENROLLED ENROLL USER?" Press **NO** to continue.
7. Remove your newly created Master I-FOB and press **RESET** to exit the Program Menu.

### D. TEST EACH TOUCHPAD PIR

Insert the newly created Master I-FOB into the Touchpad and enter the Touchpad Menu Mode by pressing **MENU**. Press **NO** until "ACTIVATE PIR TEST" appears in the LCD window and perform a test of each Touchpad PIR.

### E. TEST THE SYSTEM

After completing all tasks, perform a test of the entire system, including all Touchpads, deadbolts and transmitters.

## PANEL PROGRAMMING OVERVIEW

For proper system operation, the F-64 control panel is pre-programmed at the factory with the features listed below. The features listed below are presented here for informational purposes only--NO additional programming is needed--there is no need to enter Direct Program Mode and make additional changes unless special conditions of the installation require additional programming as determined by the installer.

1. **F-64 Control Panel:** "Disable Code-Required for EZ Bypass" enabled (address 1424; in PCD-

Windows Quickloader, this feature is located in the **Keypad Features** screen).

2. **F-64 Control Panel:** "Interior Normally Bypassed Mode" enabled (address 1422; in PCD-Windows Quickloader, this feature is located in the **System Options** screen). Enabling this feature prevents STAY zones from scrolling in the Touchpad LCD window.
3. **F-64TP-H Freedom 64 Touchpad:** "Easy Arming" enabled in keypads 1-7 (addresses 1440-1446; in PCD-Windows Quickloader, this feature is located in the **Keypad Assignment** screen).

Features numbered 4, 5 and 6 listed below are automatically configured from the factory, and also when the F-64PROG programmer is used to program zones. In PCD-Windows Quickloader Download software, these features are located in the **Zone Assignment** screen:

4. **Zone Type:** Every mapped Door Zone is a "Freedom Door" zone type.
5. **Zone Type:** Every mapped PIR Zone is a "Freedom STAY" zone type.
6. **Zone Type:** Every Non-STAY (Interior), Non-24-Hour, Non-Day Zone is a "Freedom Perimeter" zone type.

**Door Type Attributes:**

PRIORITY, SELECTIVE BYPASS, BURG OUTPUT, E/E, AUTO-RESET, and SWINGER SHUTDOWN

**Not Programmed:**

No EOL, AUTO-BYPASS, Priority with Bypass,

**All Interior (STAY) zones including the mapped integral PIR should be programmed with:**

AUTO-BYPASS, AUTO-BYPASS RE-ENTRY, SELECTIVE BYPASS, BURG OUTPUT, AUTO-RESET, SWINGER SHUTDOWN, E/E FOLLOWER, STAY and POWER UP DELAY.

See the chart below and the programming instructions WI1502 for more information regarding these pre-programmed features:

**FREEDOM-64 ZONE TYPES**

Freedom F-64 Zone Type	Priority	Auto-Bypass	Auto-Bypass Re-entry	Selective Bypass	Burg Output	E/E1	E/E2	E/E Follower	Chime	Chime 2	Report Alarm Tel1	Report Alarm Restore Tel1	STAY (Interior)	Perimeter Group Bypass
Perimeter	Y			Y	Y									Y
Perimeter (Telco 1)	Y			Y	Y						Y	Y		Y
Door E/E1	Y			Y	Y	Y								Y
Door E/E1 (Telco1)	Y			Y	Y	Y					Y	Y		Y
Door E/E1 Chime	Y			Y	Y	Y			Y					Y
Door E/E1 Chime (Telco1)	Y			Y	Y	Y			Y		Y	Y		Y
Door E/E2	Y			Y	Y		Y							Y
Door E/E2 (Telco1)	Y			Y	Y		Y				Y	Y		Y
STAY (Interior) Follower		Y	Y	Y	Y			Y					Y	
STAY (Interior) Follower (Telco 1)		Y	Y	Y	Y			Y			Y	Y	Y	
STAY (Interior) E/E1		Y	Y	Y	Y	Y							Y	
STAY (Interior) E/E1 (Telco1)		Y	Y	Y	Y	Y					Y	Y	Y	
STAY (Interior) E/E2		Y	Y	Y	Y		Y						Y	
STAY (Interior) E/E2 (Telco1)		Y	Y	Y	Y		Y				Y	Y	Y	

# INSTALLING A HARDWIRED TOUCHPAD (No transmitters needed).

## MOUNT AND WIRE THE TOUCHPAD

### 1 Open the Touchpad.

Remove the front of the Touchpad housing by inserting a screwdriver into the (2) slots in the bottom of pad and twist.



### 2 Mark the holes.

Affix the template (see page 12), to the wall adjacent to the deadbolt strike hole at a height of approx. 60" (to the top) and about 6" from the door frame.

Mark or punch through the 4 oval mounting holes and the wire access opening.

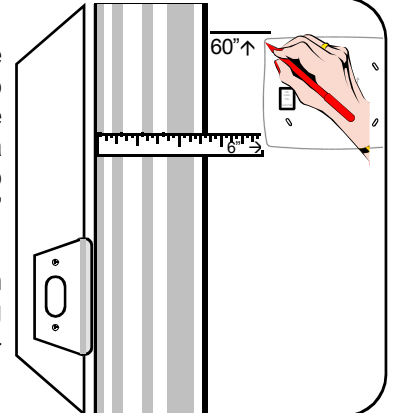

### 3 Cut access hole

Install (4) wall anchors and cut access hole in wall. Pull 4 conductor bus wire into opening. Use template as needed.

**Warning:** Use caution when cutting holes. There may be high voltage wiring in wall.

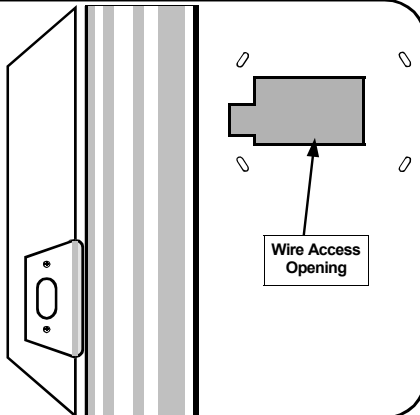

### 4 Remove the strike plate

Remove the two screws securing the deadbolt strike plate to the door frame. If there is a dust cup installed, it must be removed.

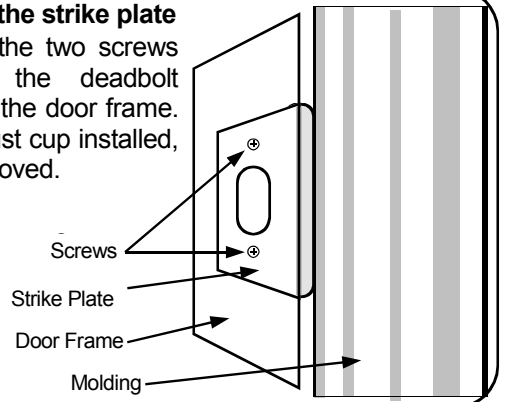

### 5 Check the depth

of the deadbolt strike hole. The F-TAB sensor requires a depth of approximately 1 1/2".

If necessary, use a 1" spade bit to increase the depth of the hole.

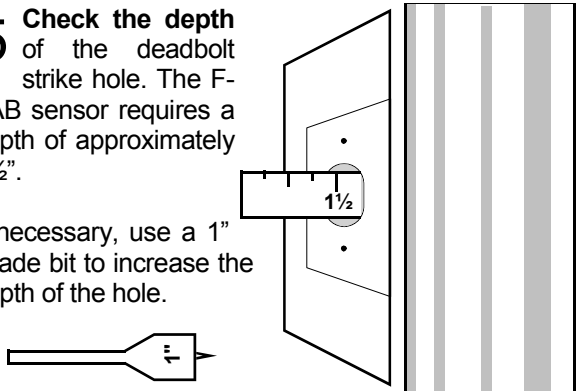

### 6 Enlarge the deadbolt hole.

The F-TAB requires a slightly larger deadbolt hole. First, secure the routing template to the deadbolt hole using the existing strike plate screws. The template will be used as a guide for enlarging the existing deadbolt hole.

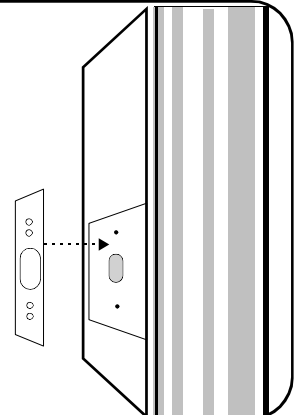

### 7 Remove the remaining wood

from the deadbolt hole opening using a rotary wood rasp (or a chisel). The opening must not obstruct the installed F-TAB deadbolt sensor or the closed deadbolt. Remove the drill guide when finished.



### 8 Test fit the F-TAB sensor

into the deadbolt strike hole. For increased kick-in protection, place the sensor "tab" closer to the inside (protected) side of the premises. Determine if the deadbolt hole will need enlarging. The F-TAB sensor requires a depth of approximately 1". In addition, one side of the deadbolt hole must be enlarged to accommodate the sensor "tab".

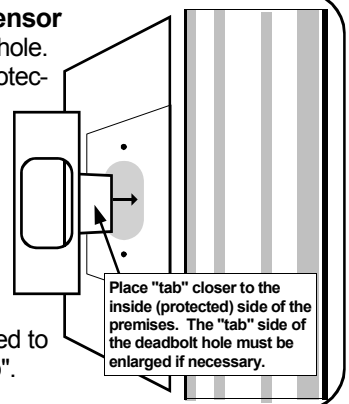

## 9 Drill holes

Drill a hole in the deadbolt hole (A) for a two conductor wire to be run from the F-TAB to the Touchpad.

Drill an additional hole (B) for a 3/8" recessed magnetic door contact sensor.

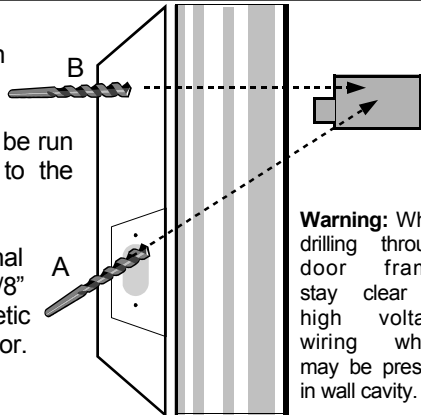

**Warning:** When drilling through door frame, stay clear of high voltage wiring which may be present in wall cavity.

## 10 Door Sensor Magnet Installation Tip:

The 3/8" hole you drilled in the door frame for the recessed door contact in step 9 can be used as an alignment guide for the magnet to be installed in the door. Close the door and push a drill bit (less than 3/8") through the hole (drilled in step 9) to mark the edge of the door. Drill a 3/8" hole in the door edge and tap the magnet in with a hammer.

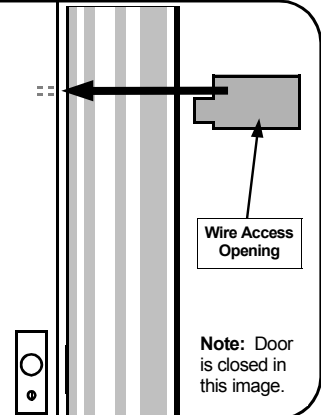

Wire Access Opening

Note: Door is closed in this image.

## 11 Install Recessed Magnetic Door Contact

Insert wire snake into access hole and through door frame. Connect end of sensor wires to wire snake and pull wires into door frame and out access hole in wall.

**Note:** To maintain Door Kick-in Protection, the door contact sensor MUST be installed on the deadbolt side of the door frame, as shown in steps 9-11.

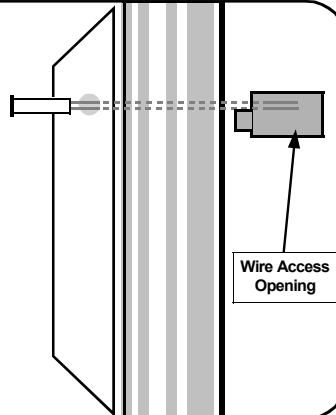

Wire Access Opening

## 12 Install F-TAB deadbolt sensor

Feed the F-TAB wires into the deadbolt hole. Using a wire snake, pull the F-TAB wires into the access hole in wall. While pulling the F-TAB wires, gently fit the F-TAB sensor into deadbolt hole. If the plastic F-TAB sensor flanges protrude past the area covered by the strike plate, it may be trimmed with a knife.

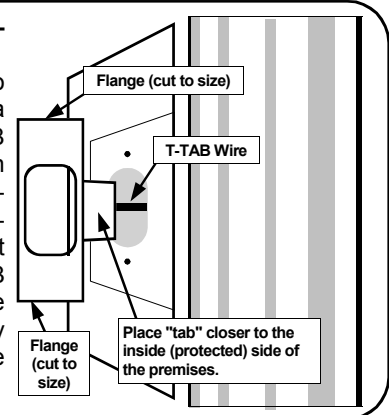

## 13 Install strike plate

Place strike plate over the F-TAB sensor. Align properly over screw holes and punch through the plastic flange of the F-TAB sensor with an awl or other sharp tool. Replace the 2 screws to secure the strike plate. Ensure that the F-TAB deadbolt sensor hole is centered in the strike plate opening.

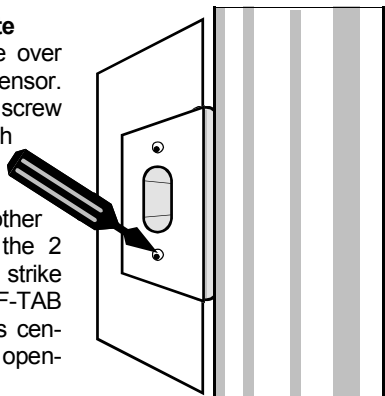

## 14 Pull wires through access hole

Pull 4 conductor bus wire from F-64 control panel through access hole opening in wall.

Next, be sure to insert wires through hole in Touchpad base. Then secure the Touchpad base to wall.

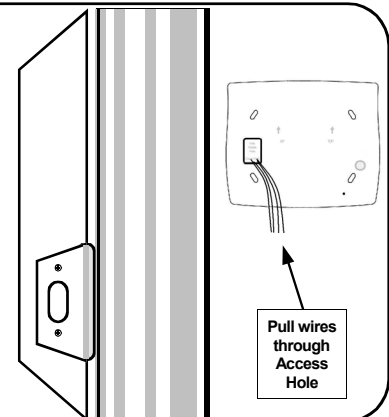

Pull wires through Access Hole

## 15 Make Connections

With Touchpad base secured to the wall, solder or crimp bus wires to the Touchpad connector plug using the wiring diagram as a guide. **Note:** Before connecting, wires can be cut to a shorter length to allow excess wires to be pushed back into the access hole opening in the wall.

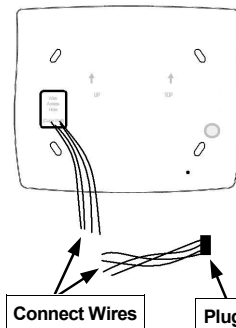

Connect Wires

Plug

## 16 Install the Touchpad Face

Double-check all connections to the Touchpad using the wiring diagram as a guide. Snap the front of the Touchpad onto the base by first inserting the 2 slots in the top onto the corresponding tabs on the base and then snapping the bottom into place.

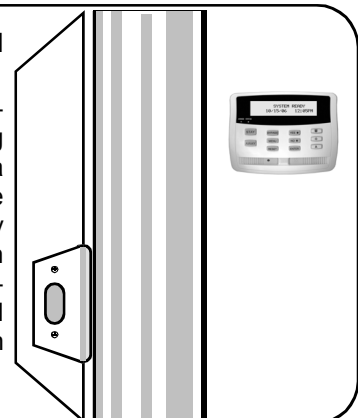

## EMERGENCY BUTTON DECALS

Position as follows:

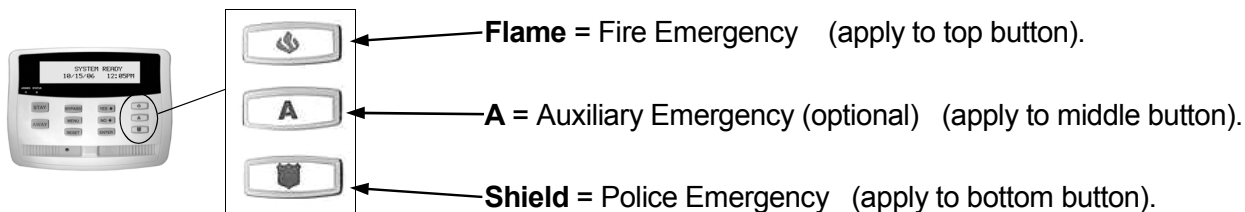

## F-64TP-H TOUCHPAD WIRING DIAGRAM

Freedom F-64 Panel Terminals and Door Contact / F-TAB / EZM Harness

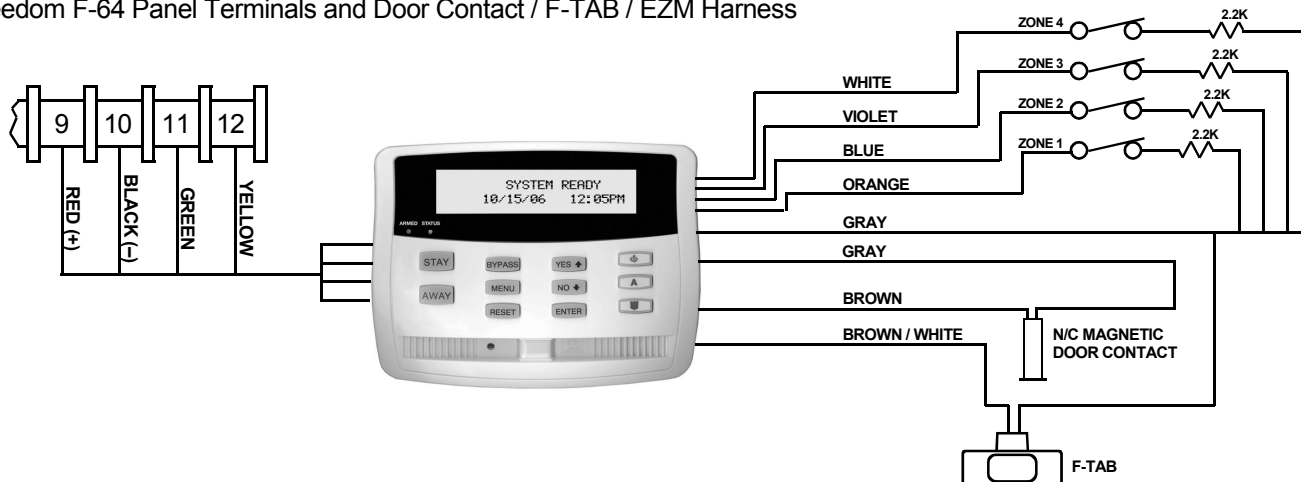

## INSTALLING MULTIPLE TOUCHPADS

Up to four F-64TP-H Hardwired Touchpads can be installed in one F-64 control panel. Each Touchpad is configured at the factory to be "Touchpad #1"; all additional keypads and Touchpads must have their keypad number changed via **Keypad Configuration Mode** (see WI1502 for instructions).

## F-64 REMOTE BUS TERMINALS

- Terminal 9** - Red wire, positive 12VDC.
- Terminal 10** - Black Wire, negative (-) GND.
- Terminal 11** - Green Wire (data)
- Terminal 12** - Yellow wire (data)

## DOOR CONTACT / F-TAB / EZM HARNESS

- Door Contact** - Brown & Gray wires.
- F-TAB** - Brown/white & Gray wires
- Zone 1** - Orange & Gray wires
- Zone 2** - Blue & Gray wires
- Zone 3** - Violet & Gray wires
- Zone 4** - White & Gray wires

## F-64TP-H TOUCHPAD PIR

The Touchpad includes an integral PIR sensor which provides the following system functions:

### Activity Sensor

The PIR is always gathering activity information which provides the system with data that is used to insure proper use of the system and prevent user errors. For example, if the user presses the AWAY button, opens and closes the door and locks the deadbolt but does not leave, the PIR will sense the user's presence in the home and automatically default to STAY mode arming, preventing a false alarm. If additional PIR sensors are installed, the activity of these sensors will also be included in these decision making processes.

### Intrusion Protection Device

When the system is armed AWAY, the PIR provides intrusion protection with a range of 25' at a 90° pattern of protection. An intruder detected in this protected area will cause the Zone mapped to the Touchpad PIR to go into alarm with the corresponding central station report.

**NOTE:** If Touchpad PIR Intrusion Protection is not desired, it may be disabled by installing configuration jumper JP1.2.

### Anti-Tamper Protection

The Touchpad PIR also includes 2 side beams which provide tamper protection for the deadbolt. These side beams provide a 170° pattern of protection, which is intended to prevent an intruder from walking along the wall towards the Touchpad and deadbolt. If an intruder is detected in the Anti-Tamper zone, the system will be put into a lockout state for a period of several minutes, during which the system may only be disarmed with an I-FOB. In cases where an extremely large signal is generated in the Anti-Tamper zone, an actual alarm may occur on the zone mapped to the Touchpad PIR.

**NOTE:** If there are windows on the wall on which the Touchpad is mounted, they should remain closed while system is armed in order to prevent a draft from causing an Anti-Tamper condition.

- If the deadbolt can be accessed from an area that is not covered by the pattern of protection provided by the Touchpad PIR, then additional protection is required. This may include protecting other doors and windows or additional space protection.
- If the Touchpad is installed adjacent to a door with glass panels or side lights, a glass-break sensor (connected to the Touchpad Aux. Zone) should be installed to insure the integrity of the system.

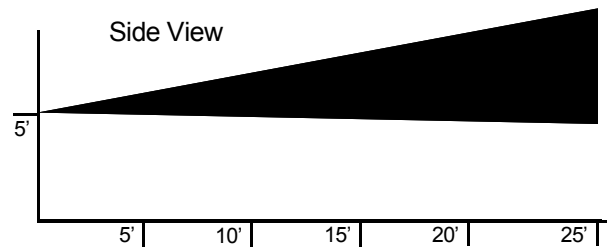
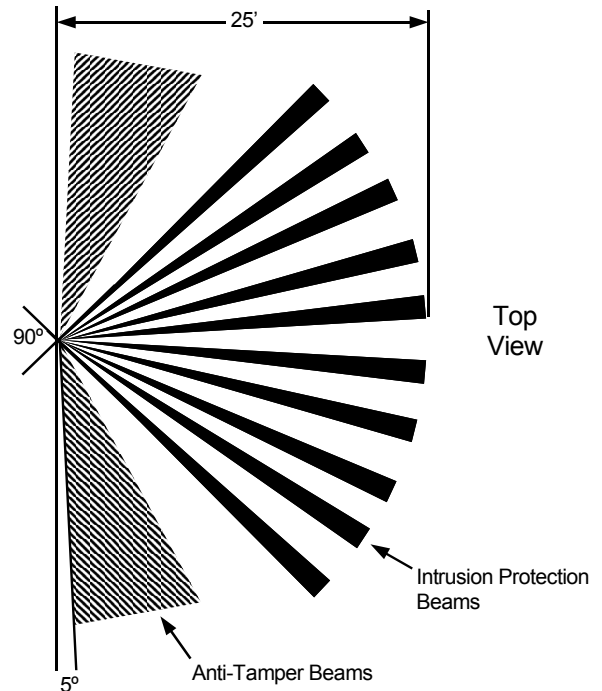

# SYSTEM OVERVIEW

## FREEDOM F-64 CONTROL PANEL (See W11501 for more information)

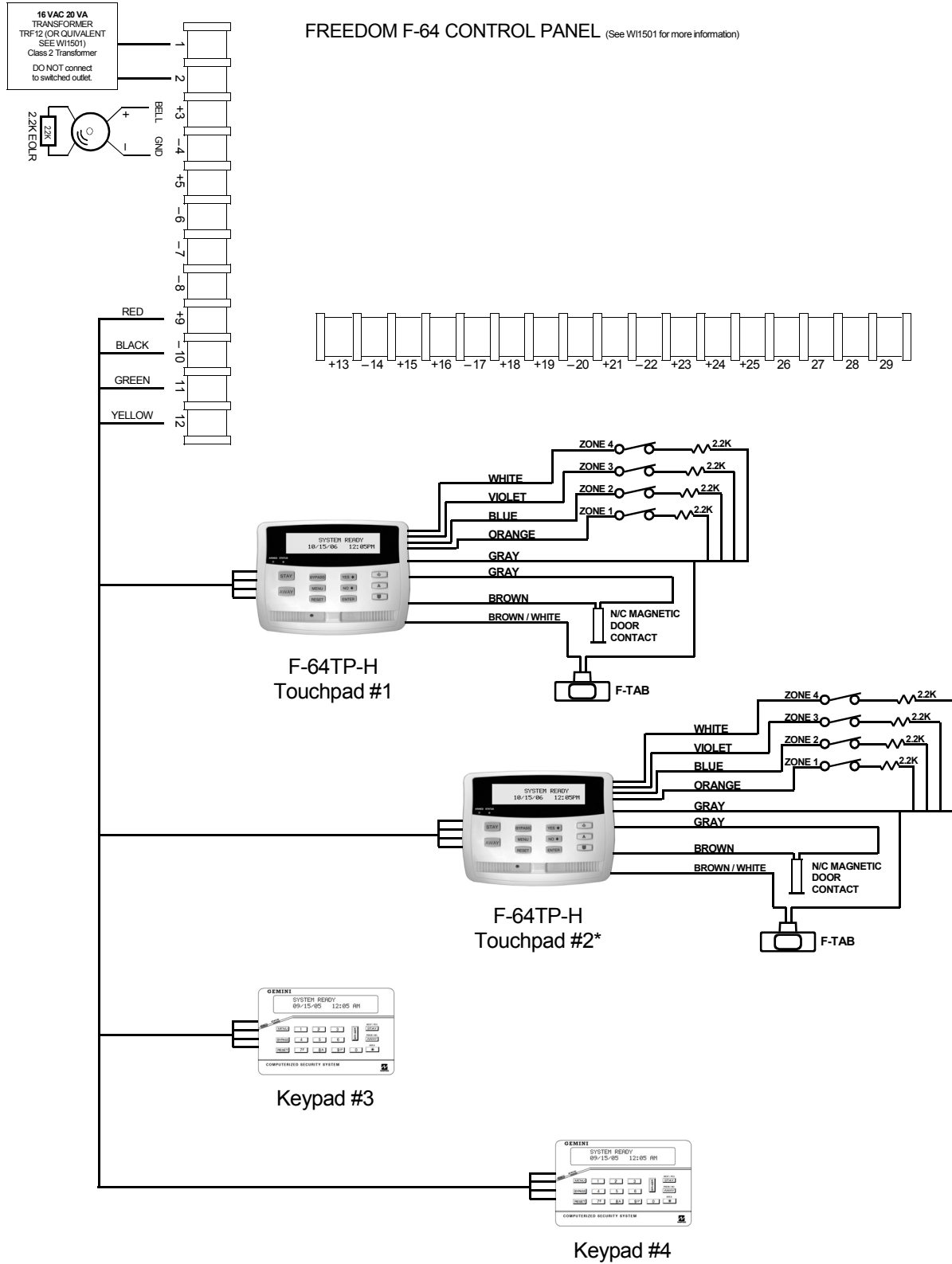

\* Multiple Touchpads and keypads must be added contiguously, without gaps. For example, if adding a second Touchpad with two additional keypads, the second Touchpad must be added as Touchpad number 2, with keypads added as numbers 3 and 4. Adding a keypad into slot number 2, with a Touchpad in slot number 3 is not allowed.

# TROUBLESHOOTING

## TOUCHPAD LIGHTS (ON FRONT OF TOUCHPAD) FAIL TO TURN ON WHEN POWER APPLIED

Check Touchpad power wires (red and black wires).

## TOUCHPAD LCD WINDOW DISPLAYS "OUT OF SYSTEM" WHEN POWER APPLIED

Green wire either open or shorted. In addition, if a system trouble appears, the yellow wire is open or shorted.

## THE TOUCHPAD FAILS TO CHIME\* WHEN OPENING THE DOOR

1. Be sure Chime is enabled by entering the Touchpad Menu Mode. On the Touchpad, press **MENU** until "Deactivate Chime" appears, thus indicating Chime is currently enabled. If "Activate Chime" appears, Chime is currently disabled (press **YES** to enable).
2. Verify the control panel is programmed for Chime to function in the system. Also verify Chime Time is programmed. See W11502 for programming instructions).
3. Check the door contact continuity and operation. Using an Ohm meter, the two door contact wires should read zero resistance when closed, and infinite resistance when open.
4. Check the deadbolt sensor. Using an Ohm meter, the sensor resistance should read approximately  $2\Omega$ , regardless of the state of the deadbolt (in or out).

## THE SYSTEM DOES NOT ARM

1. On the Touchpad, the green READY light should be on. If the READY light is not on, there is another monitored deadbolt in the system (other than the primary exit door) that is unlocked or a perimeter zone faulted. All other monitored deadbolts must be locked and all zones secured for the system to be able to arm. **Note:** Faulted Zones will scroll in the Touchpad LCD Window.
2. Verify the door contact sensor is not shorted. Using an Ohm meter, the two door contact wires should read zero resistance when closed, and infinite resistance when open.

\* The F-64 Control Panel may be programmed to disable Chime.

# NOTES

**THIS PAGE INTENTIONALLY LEFT BLANK**

# MOUNTING TEMPLATE

