



333 Bayview Avenue  
Amityville, New York 11701  
For Sales and Repairs, (800) 645-9445  
For Technical Service, (800) 645-9440  
Publicly traded on NASDAQ Symbol: NSSC

© NAPCO 2005

## NAPCO FREEDOM

# Garage Touchpad & Garage Motor Sensor INSTALLATION INSTRUCTIONS

WI1451 10/05

### GENERAL DESCRIPTION

The NAPCO Freedom Home Protection System, a revolutionary new concept in residential security, combines intuitive interactive arming with a passive disarming scheme, providing a system which is not only effortless to use, but also virtually false alarm resistant during the arming and disarming sequences.

For those who own automatic garage door openers and who regularly exit their homes through their garage, the expandable Freedom system allows for the addition of a special F-TPG Garage Door Touchpad, allowing arming and easy exit through the garage door.

The F-TPG Garage Touchpad system is armed with a simple push of a button (**STAY** or **AWAY**) on the Touchpad control module (shown at right), followed by the closing of the outside garage door. To disarm, simply open the garage door with the existing remote-controlled opener.

The microprocessor controlled F-TPG Garage Touchpad is designed to be connected to the existing automatic garage door opener hardware, using information provided by a garage door magnetic contact (magnet and sensor), a "F-GDMS" Garage Motor Sensor (connected to the garage door opener power cord) and a built-in PIR motion sensor ensuring fool-proof operation.

The garage door magnetic contact, which can be mounted in a variety of locations, senses the state of the outside garage door (closed or open) and sends this information to the microprocessor, where the decision is made to arm or disarm the system.

The F-GDMS Garage Motor Sensor is connected in series with the existing garage door opener power cord, and ensures that the garage door is always opened with the garage door motor--protecting against garage door kick-in. If the garage door magnetic contact detects that the garage door has been opened without the garage door motor being used, the system will initiate an entry delay sequence, and must be disarmed using an F-IFOB within the entry delay time.

The F-TPG Garage Touchpad's integral wide-angle PIR motion sensor acts as an occupancy sensor that provides the microprocessor with activity information which prevents the user from making errors during the critical exit and entry periods. For example, if the User presses the AWAY button, opens and closes the garage door but does not leave, the PIR will sense the User's presence in the garage and automatically default to STAY mode arming, preventing a false alarm.

If the system is armed in the AWAY mode, the F-TPG Garage Touchpad PIR will generate an alarm if an intruder is

detected. After an alarm, the system may only be silenced by inserting the F-IFOB digital key into the F-IFOB slot on the F-TPG Garage Touchpad.

By allowing this level of system control without traditional numeric keypad interaction, the Freedom System will provide a significant reduction in false alarms due to user error and also provide comfortable use of the system to those customers whose technophobic tendencies would prevent them from arming and disarming the system using a traditional keypad.

The Freedom System also prevents the arming of the alarm system if all deadbolts in the home are not engaged, a high security feature normally found only in very elaborate high-end installations.

### INSTALLATION

The Freedom system utilizes the home's existing garage door opener and requires only that the F-GDMS Garage Motor Sensor be placed in series with the 110VAC garage door opener electrical cord and the 110VAC outlet. This sensor, used in conjunction with the garage door magnetic contact, enables the system to detect operation of the garage door opener motor and the status of the garage door (open or closed). Simply remove the garage door motor electrical cord from its outlet, plug in the F-GDMS Garage Motor Sensor, secure with a screw (same as a standard transformer) and plug the power cord into the F-GDMS. The garage door magnetic contact is installed on the door and wired to the F-TPG Garage Touchpad. The Touchpad installs on a 4-wire bus and also includes an integral siren that produces 85 dB (at 10 feet).

The F-TPG Garage Touchpad includes 2 on-board zone inputs, one for the garage door magnetic contact and one for an auxiliary device such as a motion sensor, glass-break detector or other device. In just about the same time it takes to install a traditional keypad, this comprehensive module comprising of the F-TPG Garage Touchpad, F-GDMS, garage door magnetic contact, motion sensor and siren can be installed.

**NOTE:** If protecting a door or window with glass panels or side lights, an acoustic glass-break sensor (connected to the F-TPG Garage Touchpad Aux. Zone) should be installed to insure the integrity of the system.

### POWER

The F-TPG Garage Touchpad is powered by the keypad bus of the F-8 Panel. Each F-TPG Garage Touchpad draws 55mA (nominal) at 12V DC and an additional 105mA in alarm. Deduct these values from the system standby current, as described in the wiring diagram.



**This manual contains the Installation Instructions for the Freedom F-TPG Garage Touchpad & F-GDMS Garage Door Motor Sensor. It is intended to be used in conjunction with the Freedom F-8 Panel Installation Instructions (WI1431) and Freedom F-8 Panel Programming Instructions (WI1432).**

## Installing the Freedom F-TPG Garage Touchpad

Select a mounting area that provides a proper field of view for the Touchpad PIR sensor. The Touchpad PIR should **not** be placed opposite windows (see page 4 for more information). **Note:** To increase clarity, illustrations do not display door opener motor mechanisms.

### 1 Install the garage door magnetic contact.

Choose a location inside the garage so that when the garage door is closed, a magnet (mounted on the door) will be aligned with the sensor (mounted on a wall).

In the diagram at right, the two typical sensor mounting locations are: (1) vertically above the garage door or (2) horizontally near the floor. See step 2 and 3 for more information.

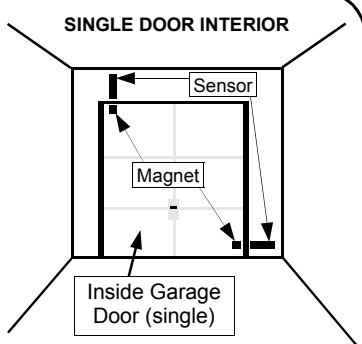

### 2 Before selecting a location for the garage door magnetic contact,

be sure to make allowances for a wire which will run from the sensor to the door input terminals (6 & 7) located inside the F-TPG Garage Touchpad.

For multiple garage doors, see step 4.

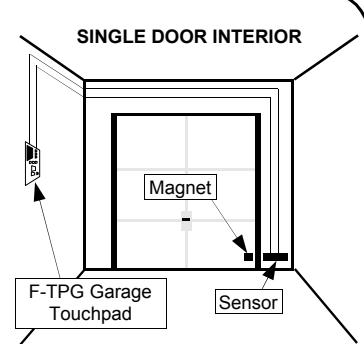

### 3 Install the F-GDMS.

Unplug the existing garage door opener motor electrical cord from its 110VAC outlet. Remove the outlet center faceplate screw. Holding the faceplate in place, plug the F-GDMS into the 110VAC outlet and replace the center faceplate screw through the hole at the top of the F-GDMS, securing the F-GDMS to the outlet. Plug the garage door opener motor power cord into the 3-prong outlet in front of the F-GDMS. See Step 3a for exploded view.

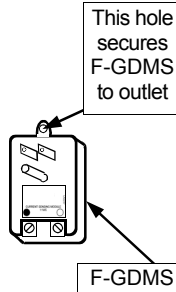

### 3a

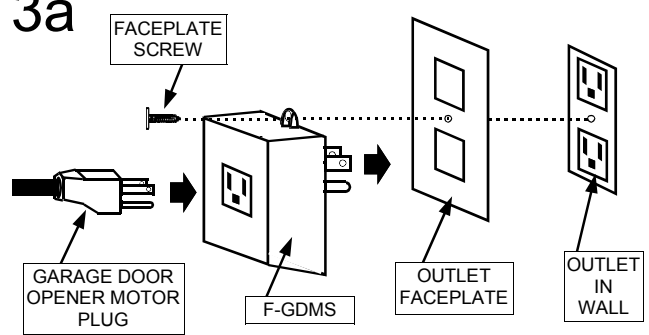

### 3b For a single garage door, wire the F-GDMS as shown:

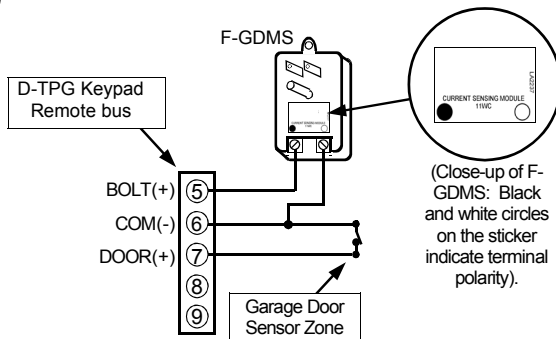

### 4 FOR MULTIPLE GARAGE DOORS, install the Door Sensor in series:

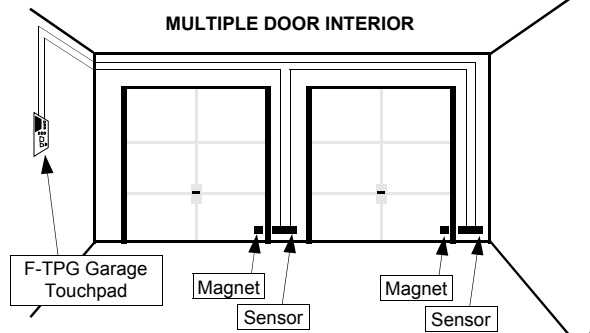

### 4a For Multiple Garage Door Openers using one outlet,

you must use a simple electrical plug power splitter. (BOTH motors must run through the F-GDMS). For two motors using two outlets, go to step 4b.

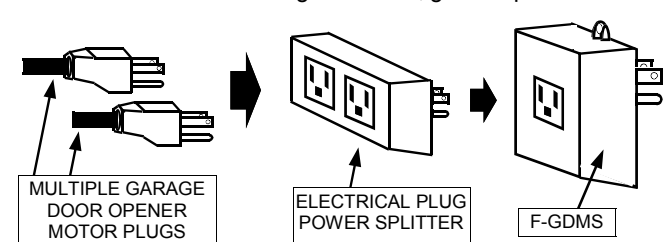

### 4b For Multiple Garage Door Openers using two or more outlets (one for each door motor),

you must use two F-GDMS's and they must be wired in series:

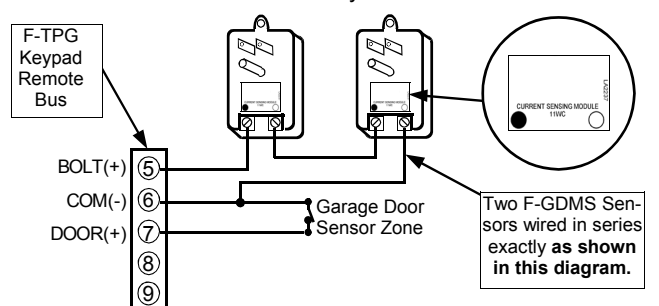

(continued)

## 5 Open the F-TPG Garage Touchpad.

Remove the front of the Touchpad housing by inserting a screwdriver into the (2) slots in the bottom of pad.

Push the screwdriver up and gently twist to unhook the plastic tabs which secure the face of the F-TPG Garage Touchpad to its base.



## 6 Mark the holes.

Mount anywhere in a room with a favorable PIR field of view, approximately 60" high (measured from the floor to the top of the F-TPG Garage Touchpad).

Affix the template (see last page of this manual) to the wall and mark or punch through the 4 oval mounting holes and the wire access opening.

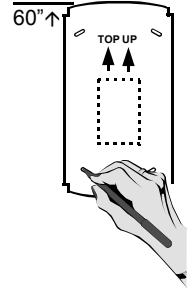

## 7 Cut access hole

Install (4) wall anchors and cut access hole in wall using the template at the end of this manual.

Pull 4 conductor bus wire from F-8 Panel and wires from the F-GDMS and garage door magnetic contact into opening.

**Warning:** Use caution when cutting holes. There may be high voltage wiring in wall.

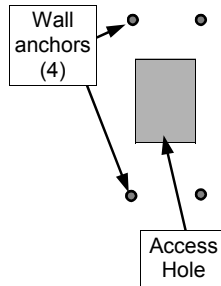

## 8 Make Connections and Create Service Loop

Punch holes with an awl in the F-TPG Garage Touchpad base fitting the wire sizes used and pull wires through base. Secure base to wall. Wire to the F-TPG Garage Touchpad using wiring diagram as a guide.

Push all excess wire back into wall leaving a short loop (about 3"-4") of slack wires for future service purposes.

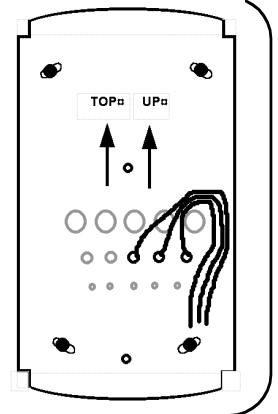

## 9 Seal access holes-- IMPORTANT:

After creating your service loop of wires, seal the access holes with putty (supplied) to ensure F-TPG Garage Touchpad is air tight. This important step is necessary to prevent air drafts from entering the Touchpad from the wall cavity.

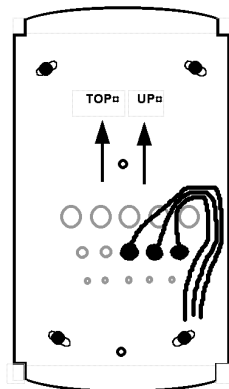

## 10 Install the F-TPG Garage Touchpad Face

Double-check all connections to the F-TPG Garage Touchpad using the wiring diagram as a guide. Snap the front of the Touchpad onto the base by first inserting the 2 slots in the top onto the corresponding tabs on the base and then snapping the bottom into place.



## 11 TEST THE SYSTEM.

Always test the operation of the F-TPG Garage Touchpad and the garage door(s) to ensure the system arms and disarms properly.

**SPECIAL TEST FOR MULTIPLE GARAGE DOORS:** In the special case of two or more garage doors which operate *simultaneously*, (i.e. with one remote control), with separate door motors powered by separate AC outlets, a failure to arm/disarm could be due to an "out of phase" condition. Re-wire by reversing the wires on one F-GDMS as shown in step 12 and re-test the system.

## 12 Wire as shown below ONLY if you encounter an "out-of phase" condition as detailed in step 11.

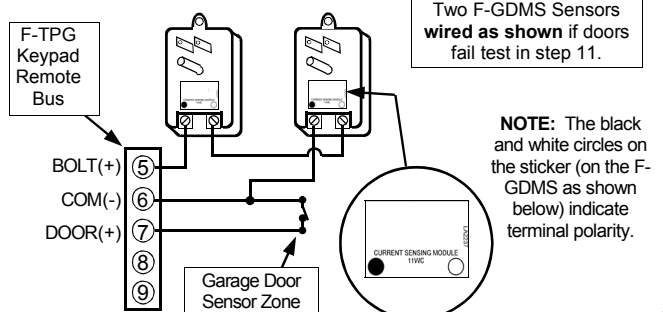



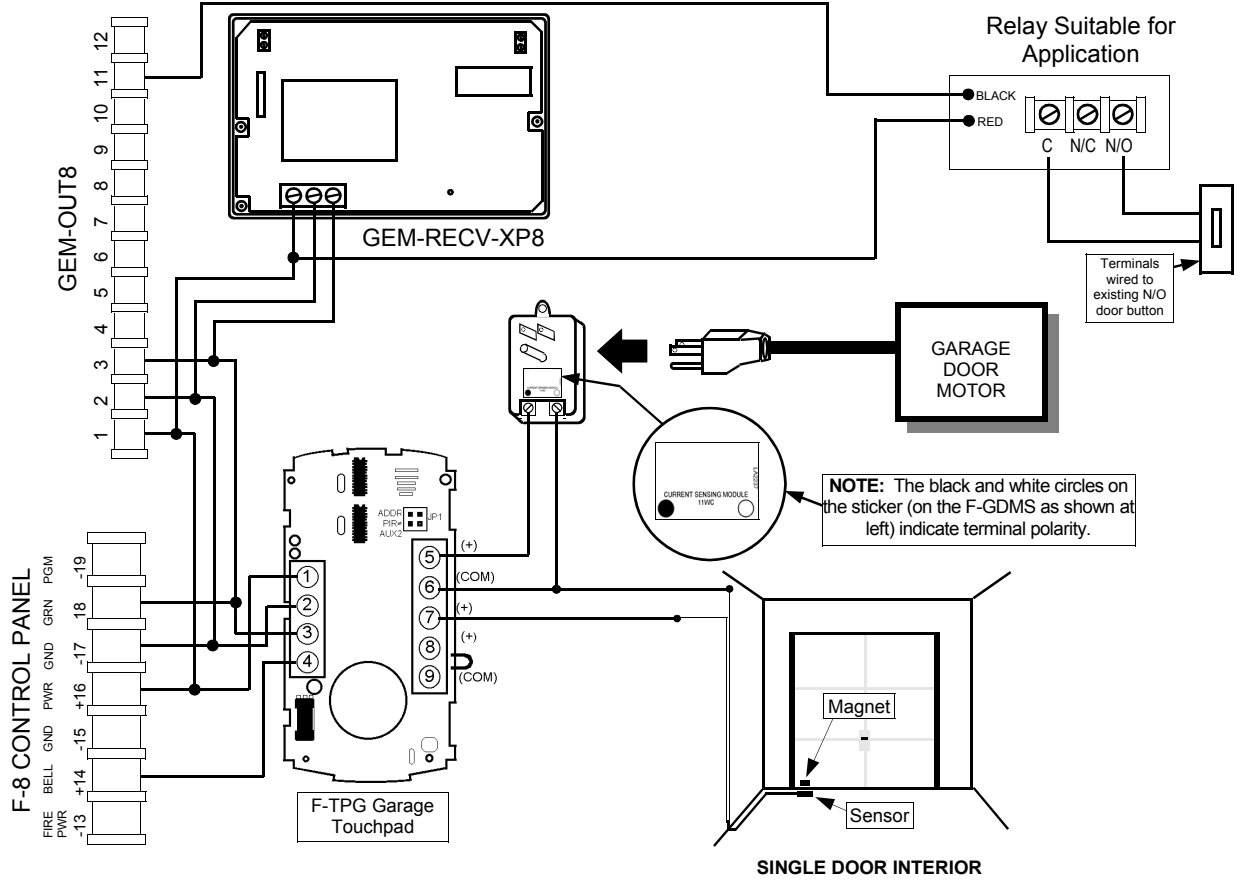

**APPROVED METHOD 2: F-TPG INSTALLATION WITH ONE GARAGE DOOR**

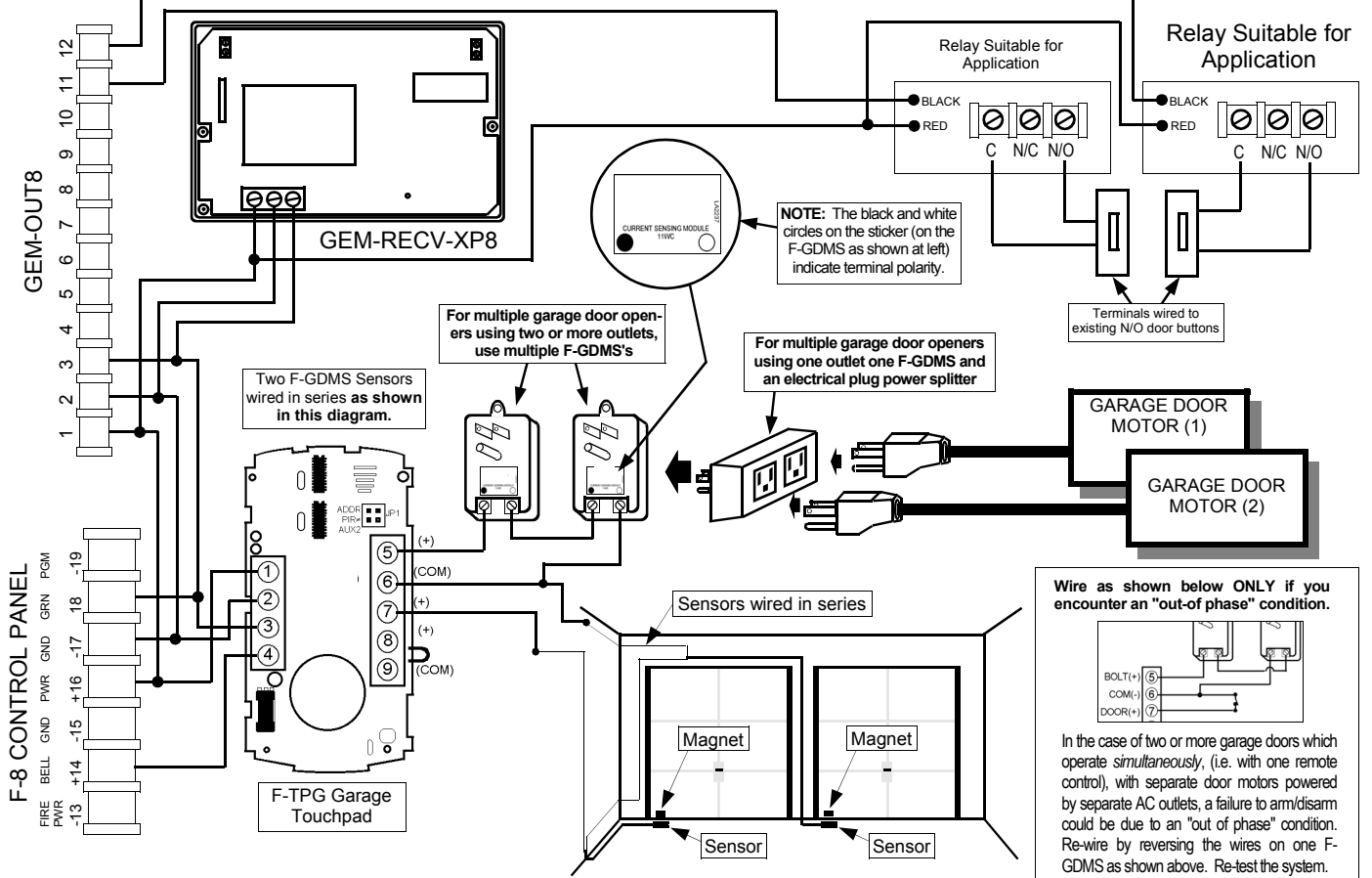

**APPROVED METHOD 3: F-TPG INSTALLATION WITH TWO GARAGE DOORS**

## F-TPG Garage Touchpad Wiring Diagram

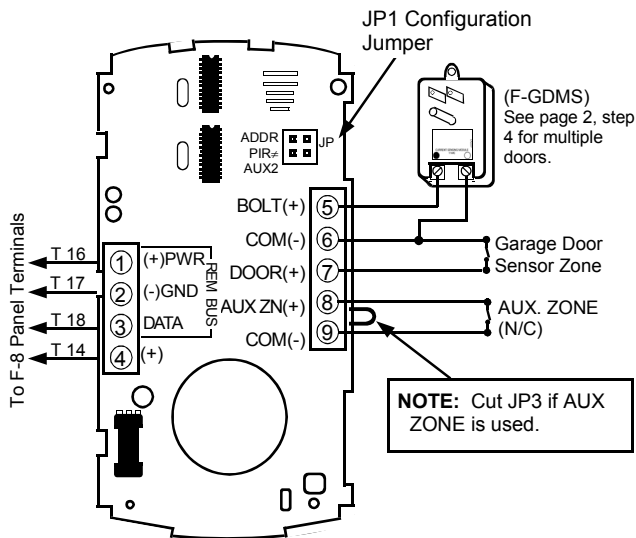

## F-TPG Touchpad Configuration Jumper JP1

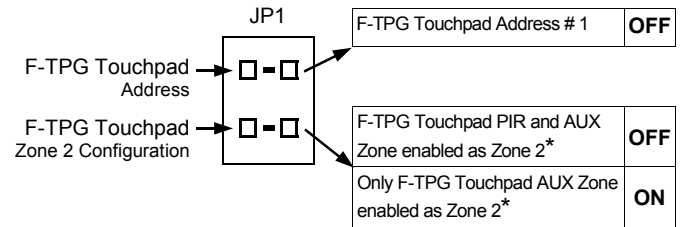

\* If AUX ZONE is used, cut Jumper 3 (JP3).

## F-TPG Garage Touchpad Address

The F-TPG Garage Touchpad must be addressed as #1. Therefore, DO NOT INSTALL jumper JP1.1 in the F-TPG Garage Touchpad.

## F-TPG Touchpad Zone 2 Configuration.

By default (JP1.2 not installed), the F-TPG Garage Touchpad's integral PIR AND the F-TPG Garage Touchpad AUX zone are configured as Zone 2 (or Zone 7 for optional Touchpad 2). A violation of either the F-TPG Garage Touchpad PIR or the AUX zone will cause a Zone 2 alarm if armed AWAY. If the AUX zone is used, the F-TPG Garage Touchpad's JP3 must be cut. See F-TPG Garage Touchpad Wiring Diagram above.

If JP1.2 jumper is installed, Zone 2 will be directed to only the AUX zone (Terminals 8 & 9). In this configuration, the F-TPG Garage Touchpad PIR will function only as an activity sensor and will not provide any protective burglary functions except to prevent an intruder from disarming the system when armed AWAY.

## F-TPG Touchpad Terminal Descriptions

### Terminals 1-3: F-TPG Touchpad Data Bus Terminals

The F-TPG Garage Touchpad communicates to the F-8 Panel via the F-8 Panel's 3-wire keypad bus. Wire the F-TPG Garage Touchpad to the F-8 Panel as shown on wiring diagram. Terminal 1 is + 12 V DC, Term 2 is GND and

Term 3 is Data.

### Terminal 4: Alarm Output

Terminal 4 is wired to terminal 14 (+ Bell) of the F-8 Panel to drive the internal alarm sounder of the F-TPG Garage Touchpad upon alarm.

### Terminal 5 & 6: Garage Door Motor Sensor (F-GDMS)

Terminals 5 & 6 are the connections for the Garage Door Motor Sensor (F-GDMS). The 2 terminals of the Garage Door Motor Sensor are wired to terminals 5 & 6. For multiple doors, see page 2 step 4.

### Terminal 6 & 7: Zone 1-Garage Door Magnetic Contact

Terminals 6 & 7 are the connections for the garage door magnetic contact.

### Terminal 8 & 9: Zone 2-Aux. Zone

Terminals 8 & 9 are the connections for the Aux Zone. This zone may be wired to a motion sensor, glass-break sensor, or a magnetic contact. If not used, the zone must be shorted. If a powered device is to be used, use terminal 1 (+ PWR) and 2 (GND) for power. Install JP1.2 jumper to disable the F-TPG Garage Touchpad PIR and enable AUX Zone as system Zone 2 (or Zone 7 for optional Touchpad 2).

## Emergency Button Decals

Position as follows:

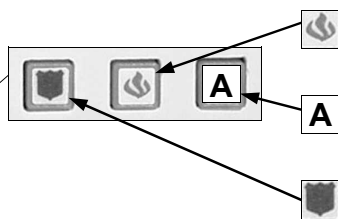

**Flame** = Fire Emergency (apply to middle button).

**A** = Auxiliary Emergency (optional) (apply to right button).

**Shield** = Police Emergency (apply to left button).

## TOUCHPAD PIR

The F-TPG GARAGE TOUCHPAD includes an integral PIR sensor which provides the following system functions:

### Activity Sensor

The PIR is always gathering activity information which provides the system with data that is used to insure proper use of the system and prevent user errors. For example, if the user presses the AWAY button, opens and closes the garage door but does not leave, the PIR will sense the user's presence in the garage and automatically default to STAY mode arming, preventing a false alarm. If additional PIR sensors are installed, the activity of these sensors will also be included in these decision making processes.

### Intrusion Protection Device

When the system is armed AWAY, the PIR provides intrusion protection with a range of 25' at a 90° pattern of protection. An intruder detected in this protected area will cause a Zone 2 alarm (or Zone 8 alarm for TP #2) with a corresponding central station report and audible alarm. **NOTE:** If Touchpad PIR Intrusion Protection is not desired, it may be disabled by installing configuration jumper JP1.2.

### Pet Protection

The F-TPG Garage Touchpad is provided with a Pet Alley Lens installed, creating a low-sensitivity zone close to the ground that will not detect pets under 24" in height. **Note:** For installations with pets, additional perimeter and/or interior protection may be required to ensure system integrity.

### Anti-Tamper Protection

The Touchpad PIR also includes 2 side beams which provide tamper protection. These side beams provide a 170° pattern of protection, which is intended to prevent an intruder from walking along the wall towards the Touchpad. If an intruder is detected in the Anti-Tamper zone, the system will be put into a lockout state for a period of several minutes, during which the system may only be disarmed with an F-IFOB. In cases where an extremely large signal is generated in the Anti-Tamper zone, an actual Zone 2 alarm (or zone 8 alarm for TP #2) may occur.

**NOTE:** If there are windows on the wall on which the Touchpad is mounted, they should remain closed while system is armed in order to prevent a draft from causing an Anti-Tamper condition.

- If the garage door opener can be accessed from an area that is not covered by the pattern of protection provided by the Touchpad PIR, then additional protection is required. This may include protecting other doors and windows or additional space protection.
- If the Touchpad is installed adjacent to a door with glass panels or side lights, a glass-break sensor (connected to the F-TPG Garage Touchpad Aux. Zone) should be installed to insure the integrity of the system.

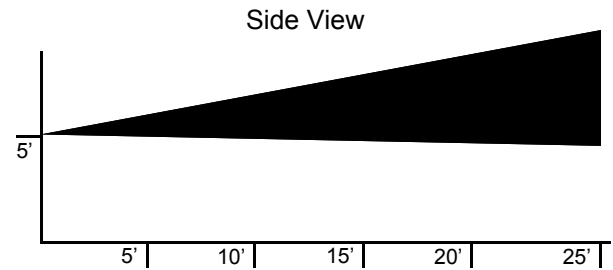
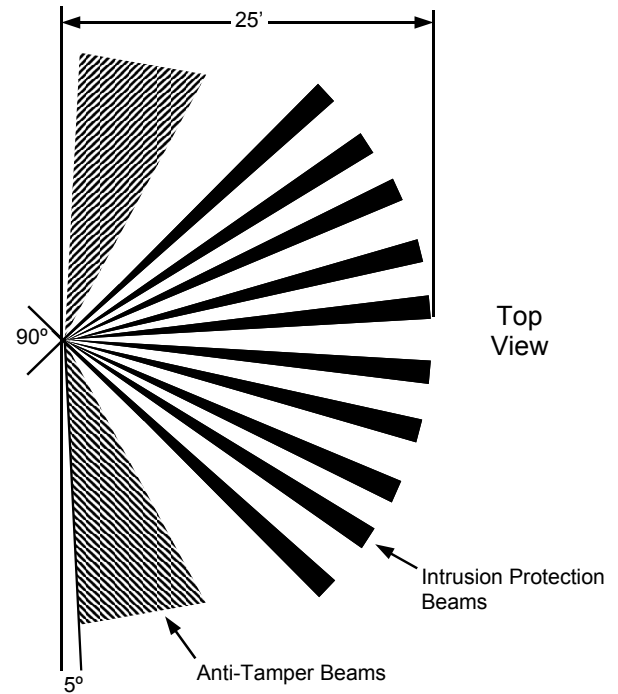

## PROGRAM THE GEM-KEYF-LR FOR GARAGE DOOR CONTROL

Program the GEM-KEYF-LR Keyfob by entering the 7 digit RF ID# printed on the label on the transmitter, along with the options for the A1 and A2 buttons to control up to two garage door motors.

### Keyfobs

				RF ID #	A1	A2
81	Keyfob 1: Press	<input type="button" value="RESET"/>	<input type="button" value="8A"/>	<input type="button" value="1"/>	<input type="text" value="6"/>	<input type="text" value="6"/>
82	Keyfob 2: Press	<input type="button" value="RESET"/>	<input type="button" value="8A"/>	<input type="button" value="2"/>	<input type="text" value=""/>	<input type="text" value=""/>
83	Keyfob 3: Press	<input type="button" value="RESET"/>	<input type="button" value="8A"/>	<input type="button" value="3"/>	<input type="text" value=""/>	<input type="text" value=""/>
84	Keyfob 4: Press	<input type="button" value="RESET"/>	<input type="button" value="8A"/>	<input type="button" value="4"/>	<input type="text" value=""/>	<input type="text" value=""/>

**PROGRAM KEYFOB BUTTONS**

Enter a "6" for Garage Door #1 Control (activated by A1 button) in the A1 column.

Enter another "6" for Garage Door #2 control (activated A2 button) in the A2 column.

### GEM-KEYF-LR KEYFOB TRANSMITTER EXAMPLE:

Map an GEM-KEYF-LR with RF ID# 0015C0:0 to Keyfob 1 (panel address 81) to open garage door numbers 1 and 2:

1. Enter Installer Program Mode.
2. Select Keyfob number 1 (address 81). Press  (beeps)   (beeps).
3. Enter RF ID number: Press         (beeps).
4. Enter Option 6 for each Keyfob button: Press  (beeps)  (beeps).

# SYSTEM OVERVIEW

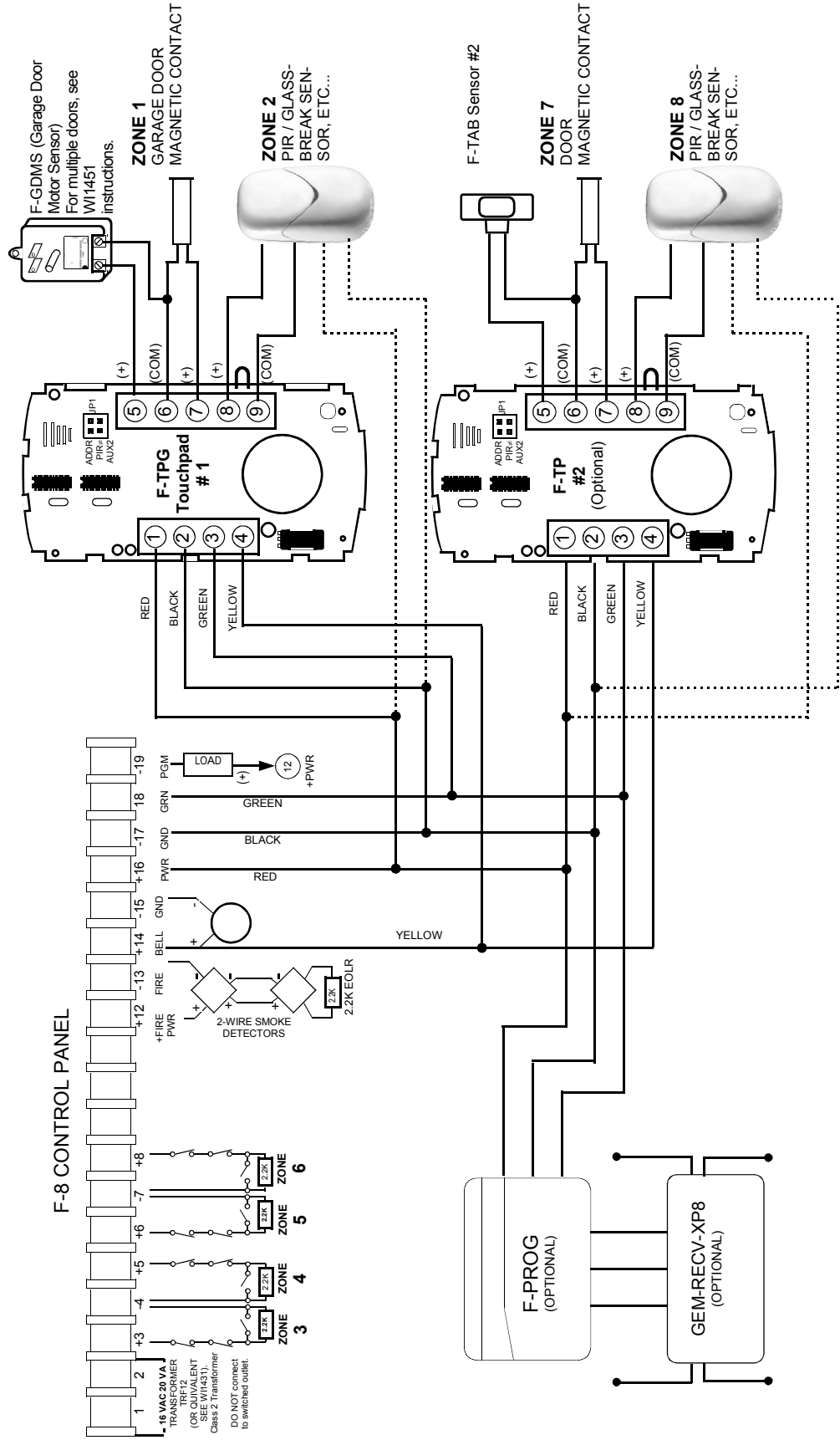

# NOTES

**THIS PAGE INTENTIONALLY LEFT BLANK**

# MOUNTING TEMPLATE

