



333 Bayview Avenue
Amityville, New York 11701
For Sales and Repairs, (800) 645-9445
For Technical Service, (800) 645-9440
Publicly traded on NASDAQ Symbol: NSSC

© NAPCO 2005

NAPCO FREEDOM

F-TP Touchpad & F-MTAB

INSTALLATION INSTRUCTIONS

WI1448 10/05

Installing the Wireless Freedom F-TP Touchpad and the F-MTAB:

The F-MTAB must be installed within the door frame, and positioned for location and depth of the extended deadbolt. The stock mortise bolt cup is oversized, allowing it to be cut to fit a variety of different door frame and deadbolt locations and sizes. Install as follows:

- 1 Open the F-TP Touchpad.** Remove the front of the F-TP Touchpad housing by inserting a screwdriver into the (2) slots in the bottom of pad.

Push the screwdriver up and gently twist to unhook the plastic tabs which secure the face of the F-TP Touchpad to its base.



Push tabs up and twist

- 2 Mark the holes.** Affix the template, to the wall adjacent to the deadbolt strike hole at a height of approx. 60" (to the top) and about 6" from the door frame.

Mark or punch through the 4 oval mounting holes and the wire access opening.

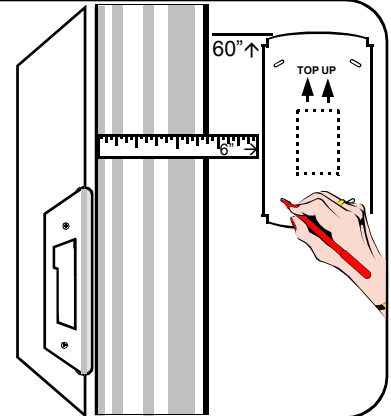

- 3 Cut access hole** Install (4) wall anchors and cut access hole in wall.

Pull 4 conductor bus wire from F-8 Panel into opening.

Warning: Use caution when cutting holes. There may be high voltage wiring in wall.

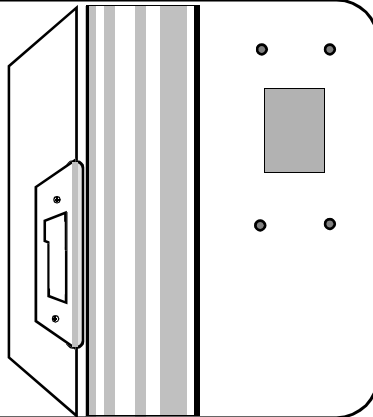

- 4 Find the existing deadbolt position.** Open door, extend the deadbolt, close and hold deadbolt against the door frame. With a pencil, lightly mark the deadbolt location and depth on the door frame.

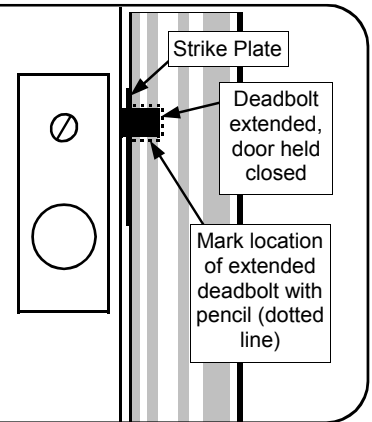

- 5 Remove the strike plate** Remove the two screws securing the deadbolt strike plate to the door frame. If there is a dust cup installed, it must be removed.

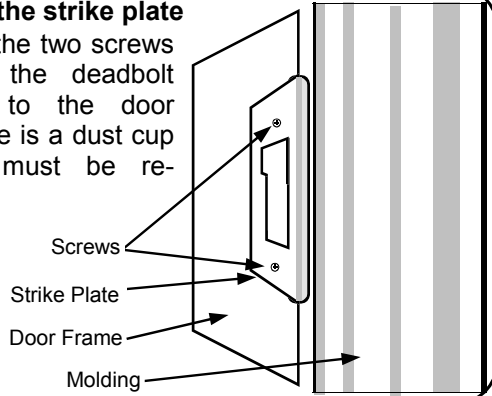

- 6 Determine F-MTAB size.** Hold the F-MTAB against the outside door frame, aligning the sensing area of the F-MTAB with the marks made in step 4. The top of the F-MTAB must align with the top of the extended deadbolt.

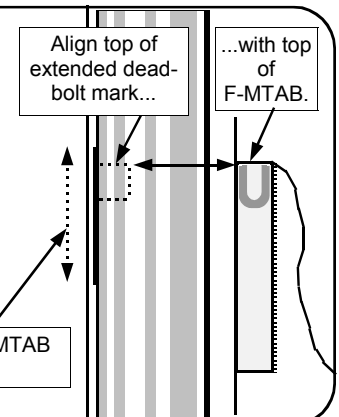

This manual contains the Installation Instructions for the Freedom F-TP Touchpad & F-MTAB. It is intended to be used in conjunction with the Freedom F-8 Panel Installation Instructions (WI1431), the Freedom F-8 Panel Programming Instructions (WI1432), and the Freedom F-TP Touchpad Installation Instructions (WI1439)

7 Mark size of F-MTAB. Since the entire F-MTAB assembly must fit within the door frame, use a pencil to mark the needed F-MTAB length (place the pencil marks directly on the F-MTAB).

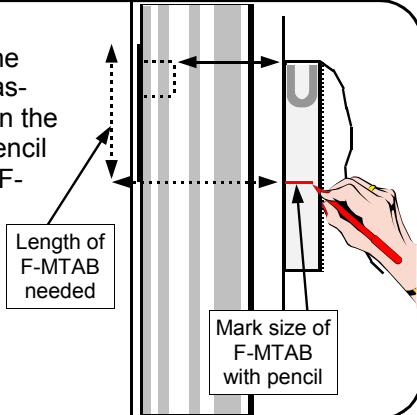

8 Cut F-MTAB to size. With a utility knife, cut away the unneeded length of the F-MTAB. To ease cutting, follow one of the horizontal ridges in the F-MTAB body.

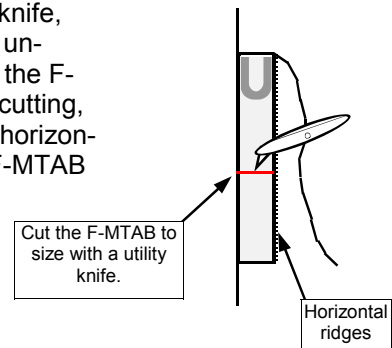

9 Install the end cap. Slide the small end cap into the open end of the F-MTAB, forming a flange on the lower end of the F-MTAB. The end cap is secured by the horizontal ridges in the F-MTAB body.

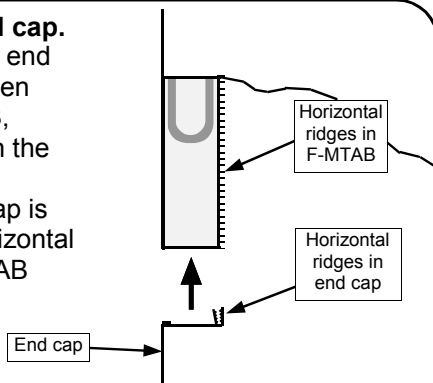

10 Cut flanges to fit. Place the F-MTAB into the door frame hole. With a utility knife, cut the upper and lower flanges to fit the size of the strike plate.

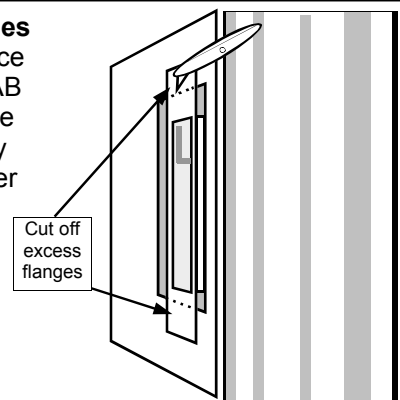

11 Check the depth of door frame hole. Minimum depth is 1" to fit the F-MTAB. If necessary, use a 1" spade bit to increase the depth of the hole as needed.

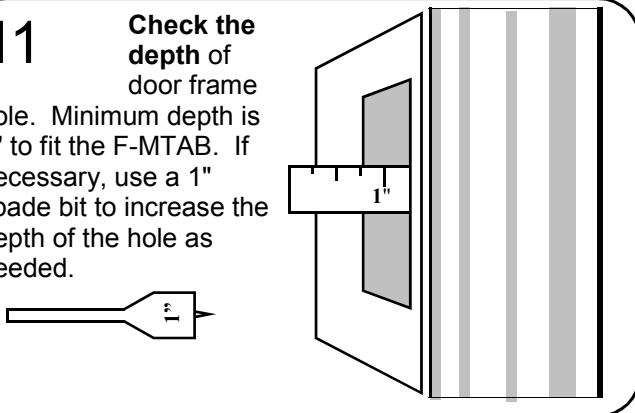

12 Drill access holes Drill a hole in the deadbolt opening (A) for a two conductor wire to be run from the F-MTAB to the F-TP Touchpad.

Drill an additional A hole (B) for a 3/8" recessed door contact sensor.

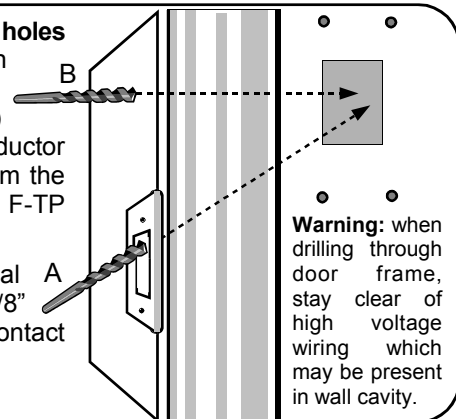

Warning: when drilling through door frame, stay clear of high voltage wiring which may be present in wall cavity.

13 Door Sensor Magnet Installation Tip:

The 3/8" hole you drilled in the door frame for the recessed door contact in step 9 can be used as an alignment guide for the magnet to be installed in the door. Close the door and push a drill bit (less than 3/8") through the hole (drilled in step 12) to mark the edge of the door. Drill a 3/8" hole in the door edge and tap the magnet in with a hammer.

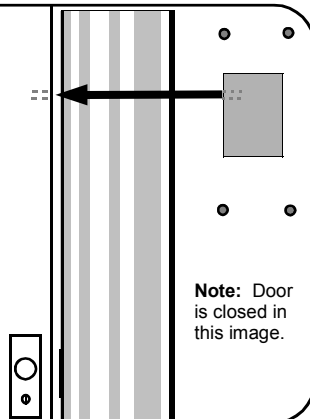

14 Install Recessed Door Contact

Insert wire snake into hole through door frame. Connect end of sensor wires to wire snake and pull wires into door frame and out access hole in wall.

Note: To maintain Door Kick-in Protection, the door contact sensor MUST be installed on the deadbolt side of the door frame, as shown in steps 12-14.

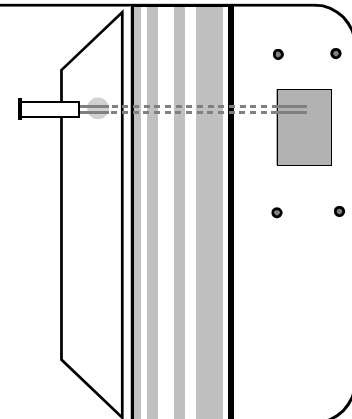

15 Install F-MTAB

Using a wire snake, pull wire into deadbolt strike hole and out access hole in wall. Connect wires to rear of F-MTAB with screwdriver.

Place the F-MTAB into hole. If the plastic F-MTAB flange protrudes past the area covered by the strike plate, it may be trimmed with a knife.

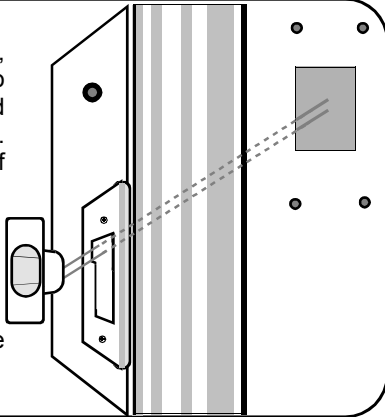

16 Install strike plate

Place strike plate over the F-MTAB. Align properly over screw holes and punch through the plastic flange of the F-MTAB with an awl or other sharp tool. Replace the 2 screws to secure the strike plate. Insure that the plastic F-MTAB is centered in the strike plate opening.

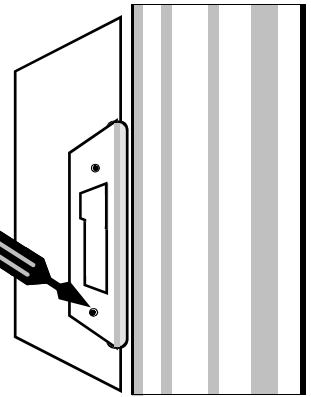

17 Make Connections and Create Service Loop

Punch holes with an awl in the F-TP Touchpad base, fitting the wire sizes used and pull wires through base. Secure base to wall. Wire to Touchpad using wiring diagram as a guide.

Push all excess wire back into wall leaving a short loop (about 3"-4") of slack wires for service purposes.

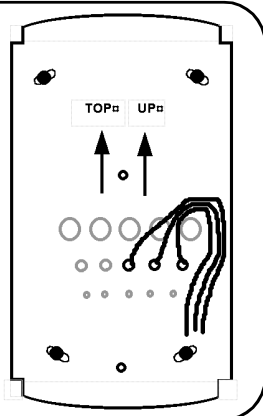

18 Seal access holes-- IMPORTANT:

After creating your service loop of wires, seal the access holes with putty (supplied) to ensure F-TP Touchpad is air tight. This important step is necessary to prevent air drafts from entering the F-TP Touchpad from the wall cavity.

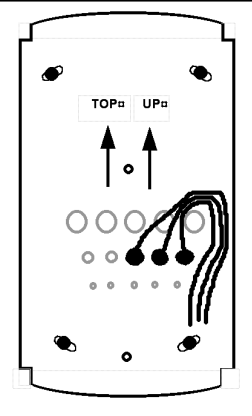

19 Install the F-TP Touchpad Face

Double-check all connections to the F-TP Touchpad using the wiring diagram as a guide. Snap the front of the F-TP Touchpad onto the base by first inserting the 2 slots in the top onto the corresponding tabs on the base and then snapping the bottom into place.

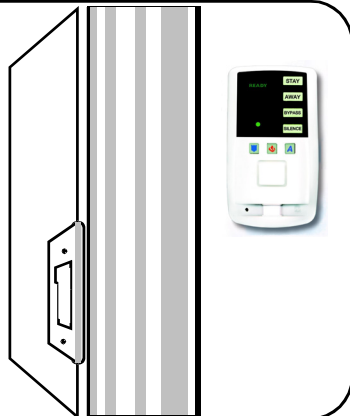

ADJUSTING THE DEADBOLT THRESHOLD

(Required for all F-MTAB Installations)

The F-TP Touchpad has been enhanced by the addition of a potentiometer, providing compatibility with the new F-TAB. This enhancement also allows shorter-throw deadbolts to be used in the system. The potentiometer adjusts the sensitivity of the deadbolt sensing circuit, and it leaves the factory turned all the way counterclockwise (low). The following adjustment procedure is required in **all** installations with the F-MTAB.

DETERMINING IF ADJUSTMENT IS REQUIRED:

After installing the system, attempt to arm with the following procedure:

1. Secure all perimeter zones. The green **READY** icon should be on steady.
2. Press **STAY**. The **STAY** icon should flash.
3. Engage the deadbolt. The system should arm Stay. The **ARMED** and **STAY** icons should be on steady.
4. If the system did not arm Stay, the Bolt Sensor circuit may not be detecting the deadbolt and needs adjustment. See procedure below:

DEADBOLT THRESHOLD ADJUSTMENT:

- 1** Open the F-TP Touchpad. Remove the front of the F-TP Touchpad housing by inserting a screwdriver into the (2) slots in the bottom of pad.

Push the screwdriver up and gently twist to unhook the plastic tabs which secure the face of the F-TP Touchpad to its base.



- 2** With the wires still connected, hold the face of the F-TP Touchpad in the palm of your hand.

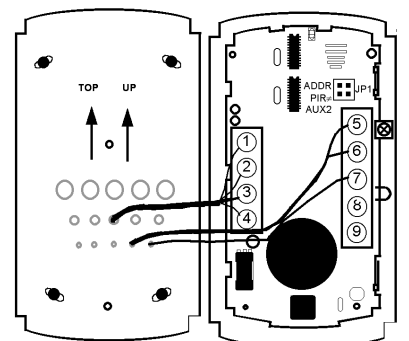

- 3** With the Touchpad in hand and the door closed, engage and disengage the deadbolt. The red LED at the top of the PCB should **turn on when the deadbolt is engaged** and **turn off when disengaged**.

- If the LED fails to light, then proceed to step 6.
- If the LED is always on, proceed to step 4.
- If the LED responds to the deadbolt correctly, the problem does not lie with the deadbolt wiring.

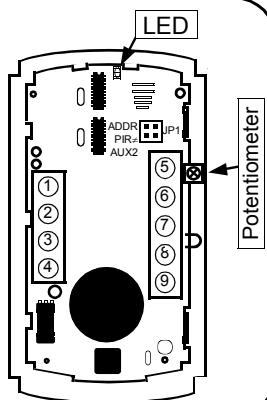

- 4** If the LED is always on, (1) turn the potentiometer fully *counterclockwise*; (2) remove power (transformer and battery); restore power and perform step 3 again. If the LED remains on, proceed to step 5.

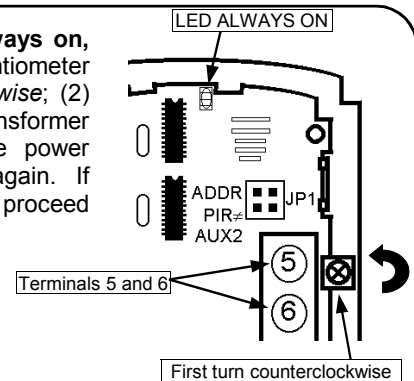

5 Remove the F-MTAB wiring from the F-TP Touchpad terminals 5 & 6; the resistance should be approximately 20Ω measured between the wires.

If the resistance is very high check for:

1. A cut wire to the F-MTAB
2. A bad connection to the screws of the F-MTAB
3. A damaged F-MTAB

If the resistance is very low check for:

1. A short on the F-MTAB wiring
2. A loose wire shorting the 2 screws of the F-MTAB
3. A damaged F-MTAB

Correct the problem and proceed to step 10. If the LED fails to light, then restart testing the system at step 3.

7 Close the door and engage the deadbolt.



9 Confirm the adjustment by disengaging and re-engaging the deadbolt.

When **disengaged**, the red LED should turn **off**.

When **engaged**, the red LED should turn **on**.



6 Make sure the potentiometer is turned fully *counterclockwise* and the red LED is off.

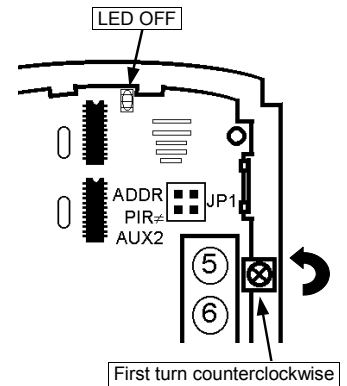

8 Slowly turn the potentiometer *clockwise* until the red LED turns on. Leave the potentiometer in this position.

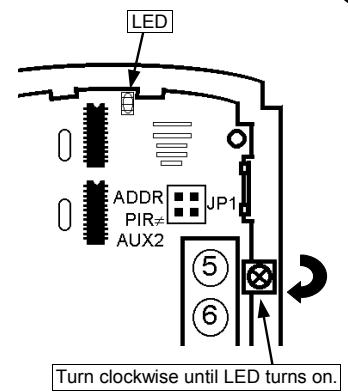

10 Before reconnecting the F-TP Touchpad front cover to the back mounting case, use the putty (provided) to seal the wiring holes in the case. When finished, be sure to continue testing the system for any further problems.

Add Putty to seal holes

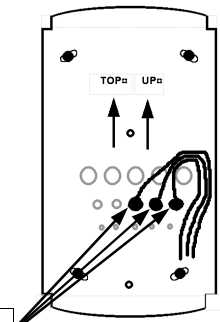

F-TP Touchpad Wiring Diagram

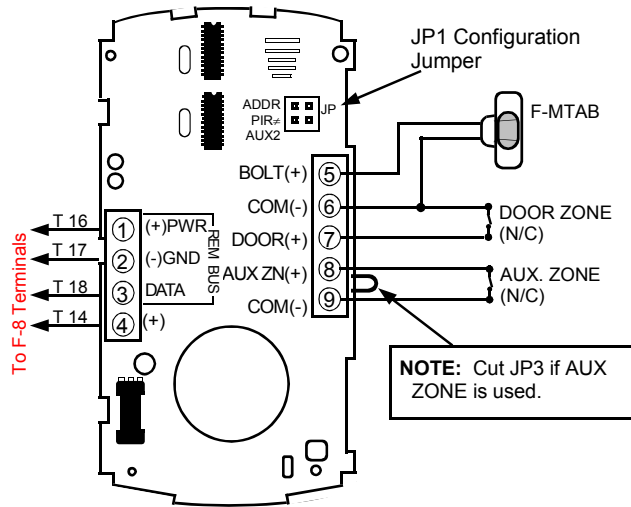

F-TP Touchpad Configuration Jumper JP1

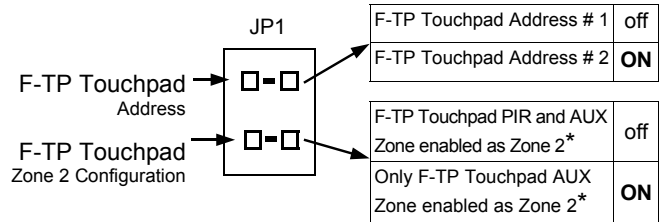

* If AUX ZONE is used, cut Jumper 3 (JP3).

F-TP Touchpad Address

Install JP1.1 for optional second F-TP Touchpad. No Jumper is required for F-TP Touchpad 1 or a single F-TP Touchpad installation.

F-TP Touchpad Zone 2 Configuration.

By default (JP1.2 not installed), the F-TP Touchpad's integral PIR AND the F-TP Touchpad AUX zone are configured as Zone 2 (or Zone 7 for optional F-TP Touchpad 2). A violation of either the F-TP Touchpad PIR or the AUX zone will cause a Zone 2 alarm if armed AWAY. If the AUX zone is used, the F-TP Touchpad's JP3 must be cut. See F-TP Touchpad Wiring Diagram above.

If JP1.2 jumper is installed, Zone 2 will be directed to only the AUX zone (Terminals 8 & 9.). In this configuration, the F-TP Touchpad PIR will function only as an activity sensor and will not provide any protective burglary functions except to prevent an intruder from disarming the system when armed AWAY.

F-TP Touchpad Terminal Descriptions

Terminals 1-3: F-TP Touchpad Data Bus Terminals

The F-TP Touchpad communicates to the F-8 Panel via the F-8 Panel's 3-wire keypad bus. Wire the F-TP Touchpad to the F-8 Panel as shown on wiring diagram. Terminal 1 is + 12 V DC, Term 2 is GND and Term 3 is Data.

Terminal 4: Alarm Output

Terminal 4 is wired to terminal 14 (+ Bell) of the F-8 Panel to drive the internal alarm sounder of the F-TP Touchpad upon alarm.

Terminal 5 & 6: F-MTAB

Terminals 5 & 6 are the connections for the F-MTAB. The 2 terminals of the F-MTAB are wired to terminals 5 & 6. The F-MTAB is non-polarized.

Terminal 6 & 7: Zone 1-Door Zone

Terminals 6 & 7 are the connections for the magnetic door contact.

Terminal 8 & 9: Zone 2-Aux. Zone

Terminals 8 & 9 are the connections for the Aux Zone. This zone may be wired to a motion sensor, glass-break sensor, or a magnetic contact. If not used, the zone must be shorted. If a powered device is to be used, use terminal 1 (+ PWR) and 2 (GND) for power. Install JP1.2 jumper to disable the F-TP Touchpad PIR and enable AUX Zone as system Zone 2 (or Zone 7 for optional F-TP Touchpad 2).

Emergency Button Decals

Position as follows:

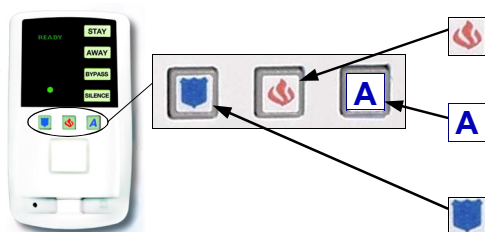

Flame = Fire Emergency (apply to middle button).

A = Auxiliary Emergency (optional) (apply to right button).

Shield = Police Emergency (apply to left button).

SYSTEM OVERVIEW

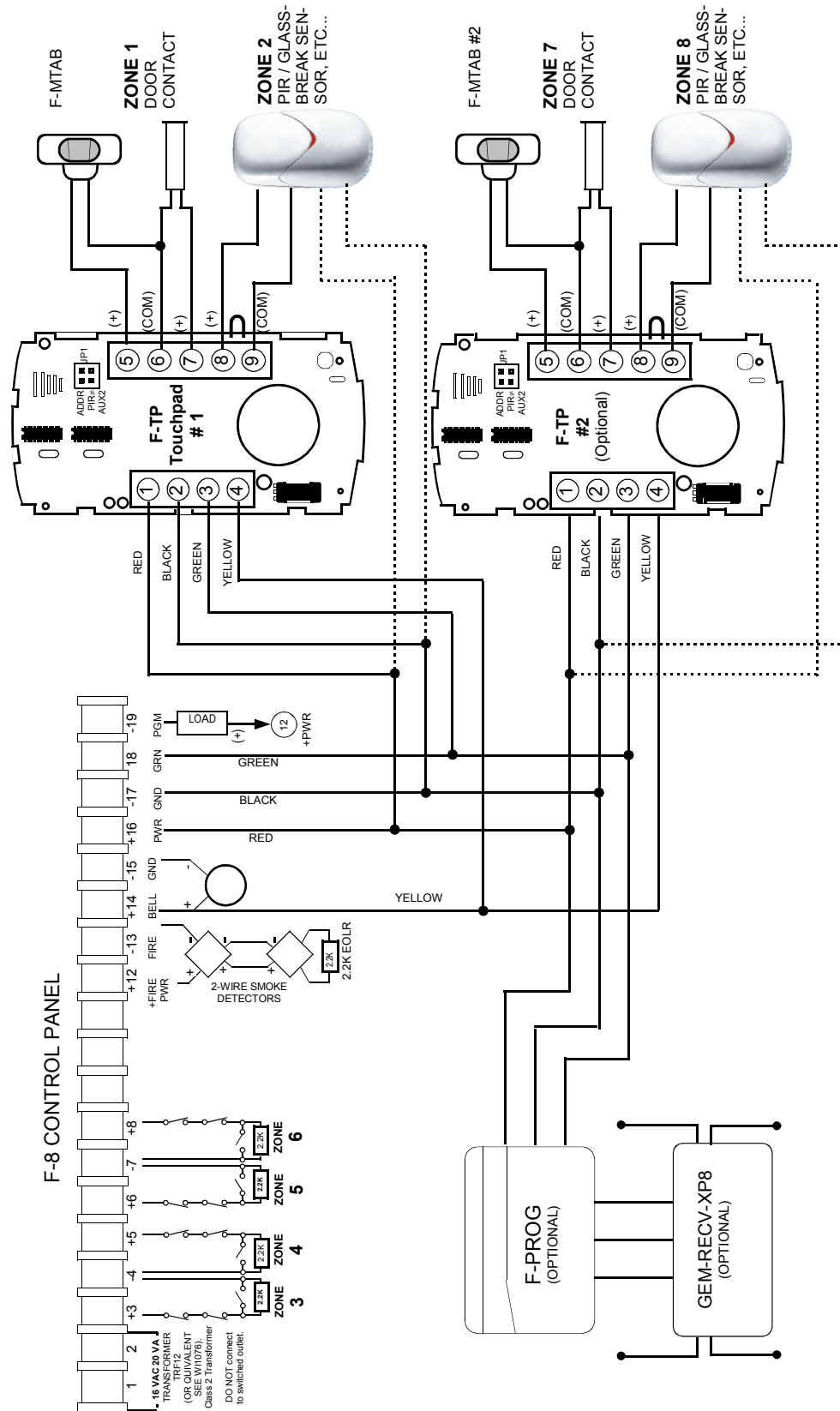

MOUNTING TEMPLATE

