



NAPCO

**BLACK BELT
BB-5 & BB-5B
ALARM CONTROL CENTERS**

Table of Contents

Section	Page
FEATURES	1
ORDERING INFORMATION	1
INSTALLATION	2
MOUNTING	2
SPECIFICATIONS	2
CONTROL CENTER WIRING	3
WIRING DIAGRAM	3
OPTIONS	9
POWER-UP SEQUENCE	15
EXIT/ENTRY DELAY TIME ADJUSTMENT	15
CONTROL CENTER OPERATION	16

FEATURES

The BB-5B is identical to the BB-5 except that the BB-5B is supplied with the recommended Gel-type lead-acid battery which is covered by a 4-year warranty. Both models have the following:

- >Two burglary protective loops:
 - >>One normally open circuit,
 - >>One instant and one delay normally closed circuit for adjustable exit/entry delay.
- >Optional Phase II backup protection.
- >Auxiliary fire protective circuit (where permitted by local bylaws).
- >Silent or audible panic.
- >Status and battery condition indication from the front of the control center.
- >Up to 5 optional remote arming stations with STATUS and ARMED indication.
 - >>Keypads for coded arming/disarming, with local audible entry delay warning, panic buttons and MEMORY indication (RP-1004) or Shunting (RP-1005).
 - >>Momentary keyswitch stations with local audible entry delay warning (RP-1006) and MEMORY indication (RP-1006 and BFC-209).
 - >>Pushbutton arming station (BFC-208B).
- >Optional fire indicator station with End-of-line resistor for supervised fire circuit monitoring.
- >Optional telephone line communicators for digital or verbal alarm reporting.

ORDERING INFORMATION

NOTE: Several products referenced in this manual have been discontinued. Please check availability before ordering.

BB-5	Alarm Control Center
BB-5B	Alarm Control Center with rechargeable battery
TRF-8	Wall mounted transformer
SNP-428	Mini-Sounder
RP-1004	3-Light Digital Keypad with Mini-Sounder, without Shunt
RP-1005	3-Light Digital Keypad with Mini-Sounder and Shunt
RP-1006	3-Light Station with Mini-Sounder and hole for keyswitch
BFC-208	2-Light Remote Station with hole for keyswitch
BFC-208B	2-Light Remote Station with push button
BFC-209	3-Light (Red/Green/Yellow) Station with hole for keyswitch
BFC-213U	Supervised Fire Remote Station
DD-1484/1486	Digital Communicators
Mark-5000/5000R	Tape Dialing Communicators
M-278	Line Reversal Module
RPB-1	Surface Mounting Box for RP-1004, RP-1005
RPB-2	Junction Box for RP-1004, RP-1005, RP-1006
WI296	Owner Manual
A167	Consumer Brochure
SDC/BB5	Briefcase Demonstrator
ESM-3	Dual Channel Siren Driver
ESM-310/ESM-301	Dual Channel Siren Driver/Siren Driver Sound Booster

INSTALLATION

MOUNTING

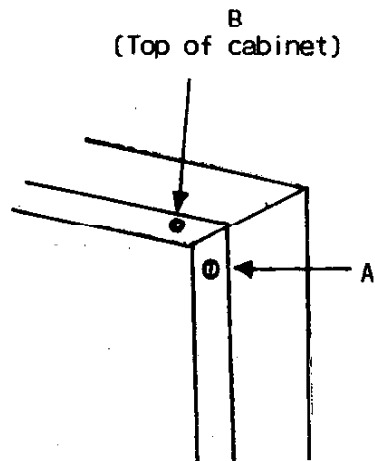

The door of the control center is screwed shut for added security. Screws are located on the right-hand edge of the cabinet door when the unit is shipped ("A", Figure 1). Figure 1 shows the top corner of the control center cabinet; the cabinet bottom has another empty hole on the bottom and a second screw on the right-hand edge. The screws provided are difficult to access if the control center is corner mounted with its right-hand edge against a wall. To allow the door to be opened if corner mounting a control center; before mounting remove the two screws provided from the holes along right-hand door edge and rescrew them into the alternate holes on the cabinet top and bottom ("B").

FIGURE 1:
IF CORNER MOUNTING, REMOVE SCREWS FROM RIGHT-HAND SIDE ("A"),
PLACE SCREWS IN HOLES PROVIDED ON TOP AND BOTTOM OF CABINET ("B").

Choose a mounting place accessible to: (1) a continuously powered AC source, (2) a cold water ground. If using an optional communicator, locate the control center accessible to telephone lines.

Remove the appropriate knockouts for the cable runs. Locate the control center at a height convenient for viewing front panel indicator lights. Mark the mounting holes.

If installing one of the optional arming or fire circuit supervision stations directly on the control center, remove the rectangular knockout on the control door. For remote location of arming stations, use an RPD-1 backplates to mount RP-1004 or RP-1005 keypads, or an RPB-2 junction box to mount RP-1004, RP-1005 keypads and RP-1006 keyswitch arming stations.

SPECIFICATIONS

Operating Voltage	16 VAC
Standby Current Drain at Idle Battery	54 mA. approximately 4 A/H Gel-type battery: (supplied with BB-5B, recommended for BB-5)
Regulated Auxiliary Output Loop Resistance	13 VDC. 500 mA. total 300 ohms maximum series resistance per loop; 10,000 ohms minimum allowed between loops
Entry Timer and Exit Timer	Both adjustable to approximately 3 minutes maximum
Burglary Output Timer	preset at 15 minutes
Dimensions	11" H x 11" W x 3.5" D
Weight	8 pounds

CONTROL CENTER WIRING

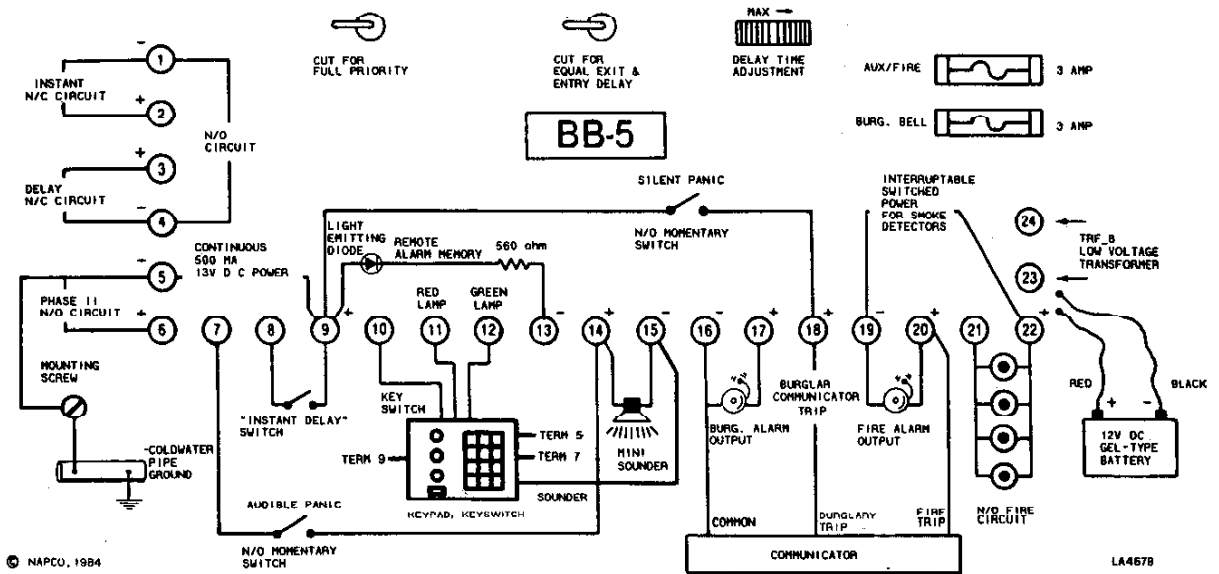

FIGURE 2: WIRING DIAGRAM

TERMINALS

1 (-) and 2 (+)
3 (+) and 4 (-)

WIRING INFORMATION (SEE FIGURE 2)

Instant Burglary Protective Circuit
Delay Burglary Protective Circuit

Two normally closed burglary loops.

Loop resistance must not exceed 300 ohms on either loop.

Voltage output appears at the burglary alarm output (terminals 16 and 17) and at the Communicator output (terminals 18 and 19).

After the control center is armed, the circuit connected to terminals 1 and 2 will trigger an alarm immediately when violated.

The circuit connected to terminals 3 and 4 is delayed for a preset time before becoming armed. This delay provides an exit time. If this circuit is violated, the control center waits for another preset (entry) time before sounding an alarm. Use to protect entrance and exit areas (front door, garage doors, etc.).

See Terminals 8 and 9 to add optional Instant/Delay switch.

If desired, after power-up follow the instructions in the "EXIT/ENTRY DELAY TIME ADJUSTMENT" section.

Supervised Loop Wiring

For the highest security installation the instant and delay loops should be wired using a two-conductor cable (Figure 3). Sensors or switches may be connected in the appropriate conductor at any position in the cable route. If the control center is armed, a short-circuit between conductors will result in an instant alarm, providing a degree of supervision.

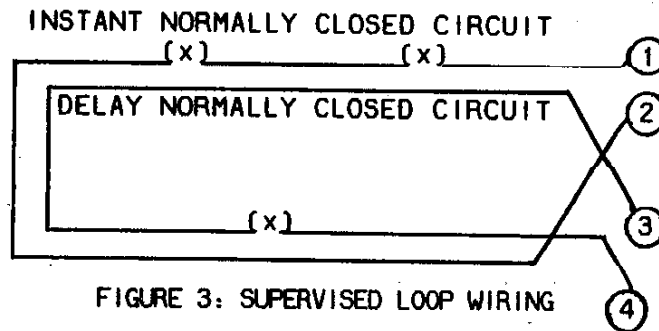

FIGURE 3: SUPERVISED LOOP WIRING

1 and 4

Instant Burglary Protective Circuit (Normally Open)

Use only momentary action normally open devices, such as floor switch mats, wired in parallel, on this circuit.

Red Jumper

Priority Arming

If an attempt is made to arm the control center when any of the burglary loops is in a trouble condition, the control unit will give an instant burglary alarm.

To reduce the possibility of causing an unnecessary alarm, cut the red "priority" jumper. (See Figure 2: Wiring Diagram.) With this jumper cut, the control center will not arm when either the normally closed instant or delay circuit is open, or if the normally open instant burglary loop has a closure.

Earth Ground

Connect an insulated wire of at least 16 gauge between terminal 5 and a good earth ground rod or a cleaned cold water pipe (Figure 4). Strip back some of the insulation a few inches from terminal 5, slacken off the printed circuit board mounting screw nearest to that terminal and wrap the wire around the screw, under the screw head. Tighten the screw firmly to ensure a good chassis ground.

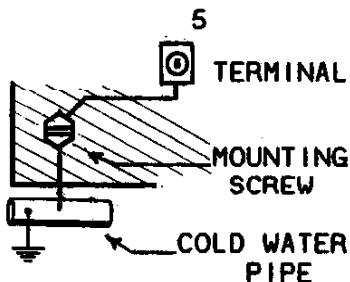

FIGURE 4:
GROUNDING

5 (-) and 6 (+)

Phase II (Normally Open Inputs)

Back-up protective circuit which is operative only after a burglary protective circuit has been violated, left open, and the alarm has

automatically timed out. Violation of any of the Phase II devices will cause the alarm to sound again.

Wire any normally open device, such as mats or ultrasonics, supplying a momentary closure across these terminals.

For added security, photoelectrics and ultrasonics can be connected to the instant and delay protective circuits and Phase II circuitry at the same time. (Figures 5A and 5B.)

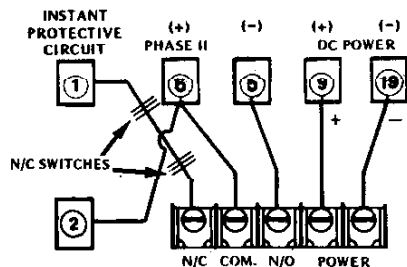

FIGURE 5A

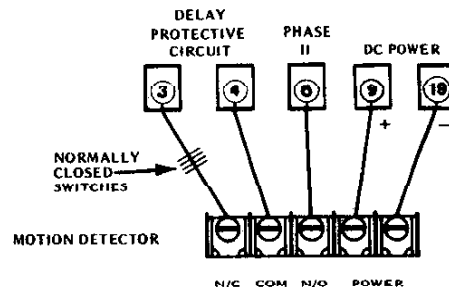

FIGURE 5B

If timeout is not necessary for the burglary protective circuits, optionally attach a jumper between the two Phase II terminals together to prevent the alarm from timing out. The control center must then be manually reset by the keyswitch. Adding this jumper eliminates the Phase II feature.

5 (-) and 9 (+)

Continuous DC Output

Constant, filtered regulated 13 volts DC voltage, at 500 milliamp. maximum.

For photoelectric, ultrasonic or similar low-current devices. Also used to supply optional arming and indicator stations. (See OPTIONS section, "Power Output Considerations" for current specifications.)

Output protected by the 3 amp. AUX/FIRE fuse.

7 (-) and 14 (+)

Audible Panic Circuit (Normally Open, 24 Hour)

Wire the normally open momentary switches and the panic function of Napco RP-1004 and RP-1005 Digital Keypads in parallel across these terminals for an audible panic alarm signal. When either the Panic buttons are pressed on the keypad, or an added switches closes, the control center will remain in alarm until reset by the keypad or keyswitch. When a panic switch closes, voltage will appear across the burglary alarm output (terminals 16 and 17) and across the Communicator output (terminals 18 and 19.) Panic alarms do not have automatic bell cut-off.

See Terminals 9 and 18 for Silent Panic.

8 (-) and 9 (+)

Instant/Delay Switch
(Optional.)

For added perimeter protection in an occupied building, wire a maintained ON/OFF switch to these terminals and mount it inside the building. To disable delay upon leaving and re-enable it before reentry, use a key operated switch and mount it outside the building.

When the switch is in the open position, or when no switch is used, the protective circuit between terminals 3 and 4 will function as a delay loop. With the switch in the closed position, the loop will give an "instant" alarm response.

9 (-) and 13 (+)

Remote Memory Indicator Output

Optionally wire up to 5 light emitting diodes (with current limiting resistors) or other low-current indicating devices between these terminals.

Total maximum current drain is 80 milliamps.

A voltage will occur at these terminals if any of the burglary protective circuits have been violated, or if either the audible or silent panic circuit has been activated.

Because they require less current and are more durable, light emitting diodes are preferable to filament bulbs. Wire in the light emitting diodes using a 560 ohm, 1/4 watt resistor for each light (Figure 6A). Observe polarity (Figure 6B). Maximum current drain is 20 milliamps. for each light emitting diode.

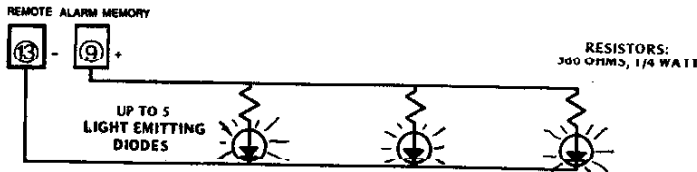
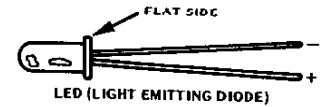

FIGURE 6A: REMOTE LED CIRCUIT



TO WIRE A LIGHT EMITTING DIODE, POLARITY MUST BE OBSERVED. MOST LIGHT EMITTING DIODES HAVE A FLAT SIDE ON THEIR RIMS NEAR THE NEGATIVE LEAD.

FIGURE 6B: LED POLARITY

9 (+) and 18 (-)

Silent Panic Circuit (Normally Open)

Optionally wire normally open momentary switches and the panic function of Napco RP-1004 and RP-1005 Digital Keypads can be wired in parallel across these terminals to provide a silent panic alarm. Either pressing the Panic buttons on the keypad, or a panic switch closure will cause voltage at terminals 18 (+) and 19 (-) (Communicator output), and the MEMORY light(s) will come on.

The Communicator output voltage will be present only during the time the silent panic circuit is closed. For this reason, the automatic abort

feature on a tape dialer should not be used, and on a digital Communicator, there should be no abort delay or restore reporting programmed to operate with the panic input.

10 (-) and 14 (+) ARM/DISARM Keyswitch
One or more normally open momentary keyswitches, or up to five remote stations, can be wired across these terminals. (See OPTIONS section.) The control center will arm or disarm on successive operations of the keyswitch.

Do not use any maintained keyswitches.

14 (+) and 15 (-) Entry Delay Warning Output
Wire the integral Mini-Sounder of the RP-1004, RP-1005 and RP-1006 stations or an optional Mini-Sounder (Napco model SNP-428) to these terminals. The sounder warns the user to disarm the control center on entry before an alarm occurs.

16 (-) and 17 (+) Burglary Alarm Output
A maximum of 3 amps. at 12 Volts DC is available across these terminals for the purpose of powering a bell or siren. Output is activated by a break in a normally open protective circuit, a closure across either the instant normally open circuit or the audible panic circuit terminals, or by momentary operation of the BELL/BATT TEST switch.

Output protected by the BURG. BELL 3 amp. fuse.

NOTE: Use no connection to terminal 16 other than the negative return from an alarm bell or siren.

Alarm Timeout

An automatic bell timer is built into the control center. The bell will ring for approximately 15 minutes. The control center will automatically reset after the bell stops ringing if the protective circuits have been restored.

To lengthen cut-off time to approximately 30 minutes, cut the designated trace on the back of the circuit board (Figure 7).

A shorter 3-minute cut-off is available from the factory on special request.

To bypass bell cut-off totally, connect a jumper wire across terminals 5 and 6. This jumper will eliminate the Phase II feature, and the control center must be reset manually.

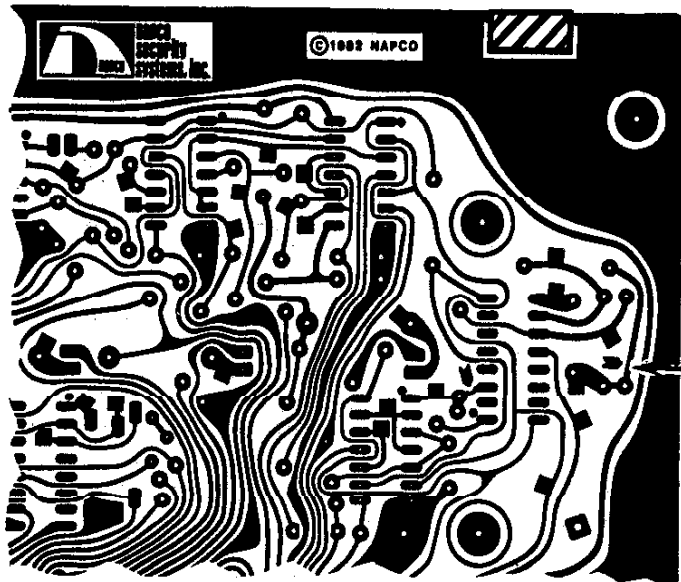

FIGURE 7:
(CIRCUIT BOARD BACK)
CUT TRACE TO
LENGTHEN TIMEOUT.

19 (-) and 20 (+)

Fire Alarm Output

A maximum of 3 amps. at 12 Volts DC is available across these terminals for the purpose of powering a bell or siren. Activated by a closing of the normally open fire protective circuit (terminals 21 and 22). This output is protected by the AUX/FIRE 3 amp. fuse.

The fire alarm device is reset with the BELL/BATT TEST and FIRE RESET switch on the front of the control center.

19 (-) and 22 (+)

Switched (Interruptable) Fire Alarm Sensor Supply

These terminals provide a regulated voltage of approximately 13 volts DC at currents up to 500 milliamps, depending on the amount of current used elsewhere for auxiliary and remote devices. (See OPTIONS, "Power Output Considerations".)

This output supplies powered fire sensors (for example, smoke detectors). Latched fire sensors are reset by depressing the BELL/BATT TEST and FIRE RESET switch on the front of the control center, which removes the power from the terminals.

21 (-) and 22 (+)

Normally Open Fire Protective Circuit

Normally open fire sensors, such as heat or smoke detectors, are wired in parallel across these terminals. A momentary closure activates the fire alarm output (terminals 19 and 20).

23 and 24

AC Power

Wire a Napco TRF-8 transformer to these terminals. The transformer must be plugged into an outlet that provides 24-hour continuous power. One of the most common causes of false alarms is the use of outlets that are switched off at the end of the day with a common circuit breaker.

Battery Leads

Battery (Required.)

The BB-5 uses a 12 Volts DC rechargeable Gel-type battery for standby power. (The BB-5B model includes a battery of this recommended type.) Observe polarity when attaching the flying leads on the right-hand side of the circuit board to the battery. The red lead is positive (+), the black lead is negative (-).

The battery provides standby control center power and powers activated alarm sounders.

Depress the BELL/BATT. TEST switch on the front of the control center to check battery condition. The battery must be allowed a reasonable charging time before the control center is fully operational, and should become fully charged within one or two days, depending upon the power line voltage, auxiliary power drain and battery condition.

AUX/FIRE Fuse

This 3 amp., 3AG, normal-blow fuse protects terminals 9, 14, 20 and 22 and affects:

- >regulated DC auxiliary output,
- >remote MEMORY light output,
- >remote arming stations,
- >Instant/Delay switch circuit,
- >Audible Panic circuit,
- >Supervised Fire Station power and sounder supply,
- >Fire Alarm output,
- >switched DC output.

When the fuse is removed or blown, all green STATUS lights go out, and remote red ARMED lights will not go on.

BURG BELL Fuse

This 3 amp., 3AG, normal-blow fuse protects the Burglary Alarm output (terminals 16 and 17).

When the fuse is removed or blown, the green STATUS lights will go out. (Trouble Shooting Tip: If all loops are known to be intact but the green light still does not go on, the BURG BELL fuse should be checked.

NOTE: Do not connect anything to terminal 16 other than the negative return from an alarm bell or siren to terminal 16.

OPTIONS

POWER OUTPUT CONSIDERATIONS

The internal power supply of the control center delivers a continuous regulated output voltage of approximately 13 volts DC at a total current of 500 milliamps delivered from the two available outputs, terminals 5 (-) and 9 (+), 19 (-) and 22 (+).

Some of this current is used by arming and indicator stations, if any are connected to the control center. Table 1 shows the amount of current drawn by each.

<u>Napco Station (part number)</u>	<u>Current drain (single station)</u>
BF-208	40 milliamps.
BF-208B	40 milliamps.
BF-209	25 milliamps.
RP-1004	40 milliamps. (1)
RP-1005	50 milliamps. (1)
RP-1006	25 milliamps. (1)
BFC-213U	20 milliamps. (1)

(1) Note: Each Mini-Sounder draws an additional 12 milliamps. while operating.

TABLE 1

The remaining current may be used to provide power for burglary or fire sensors.

The alarm sounders will draw part of their power from the battery when an alarm is activated.

MODULE

WIRING INFORMATION (SEE FIGURE 2)

Tamper Switches

May be installed to guard against removal of the control center cabinet from the wall and/or opening of the control center door.

If used, tamper switches should, ideally, be connected to a 24 hour circuit.

For use with the Panic circuit or another normally open circuit, wire normally closed switches in parallel. Use Napco TPS-2 (normally open) switches in series when using a normally closed circuit.

Locations in the cabinet of tamper switch mounting holes:

- (1) For protection against removal of the cabinet from the wall, use mounting holes on the left-hand side. There are three mounting holes and an adjacent hole on the back of the cabinet. Tamper switch button will contact the wall.
- (2) To cause an alarm if the cabinet door is open, use the 3 mounting holes on the right-hand side. Tamper switch button will make contact with the closed cabinet door.

Be sure to alert the end-user that opening the control center door, (for example) to check the fuses, causes a tamper alarm.

Arming Stations

Use a maximum of 5 remote keypads, keyswitches and pushbutton stations combined.

Total current drain from all lights should not

exceed 160 milliamps.

Wire all remote stations in parallel. A maximum total run of up to 500 feet can be made using 22 gauge wire.

Digital Keypads

For coded arming and disarming, use Napco model RP-1004 or RP-1005 Universal Digital Keypad Stations. Both keypads provide ARMED (red) and STATUS (green) indication, panic activation, and Mini-Sounder entry delay warning signal. The RP-1004 has a MEMORY light (red).

The RP-1005 also provides a S (shunt) button, and SHUNT light (yellow). The shunt feature allows the user to arm selectively while the premises is occupied, and can be connected to an entire burglary loop or a portion of a burglary circuit containing one or more normally closed devices.

The code is selected with the white leads and the socket holes number 1 to 4 on the back of the RP-1004 or RP-1005 keypad circuit board.

Key relay operation is selected with the red lead and the socket holes labeled A and B, also on the back of the circuit board. BLACK BELT control centers use momentary relay operation only. Therefore, the red lead must be connected to socket hole B, or the system will not arm or disarm from the keypad.

See the instructions with the keypad used for details of operation and code selection.

Use Figure 8 to connect keypad to the BB-5 or BB-5B terminals. CAUTION. Avoid splashing solder on keypad circuit board. Solder splashes are the most common cause of keypad malfunction.

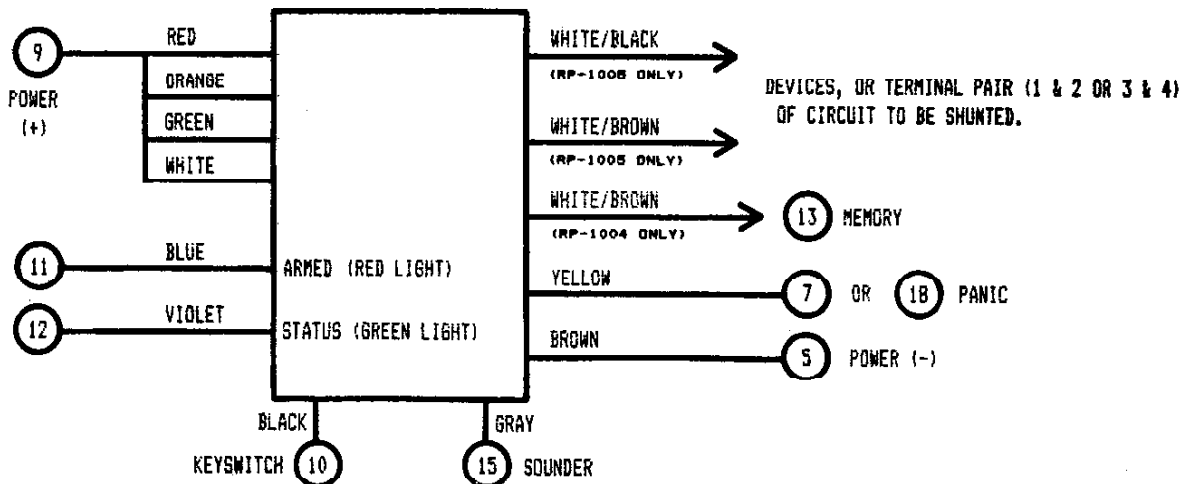

FIGURE 8: NAPCO RP-1004/RP-1005 KEYPADS

Keyswitch and

Pushbutton Stations The Napco RP-1006 Keyswitch Station provides Mini-Sounder entry delay warning and 3 lights labeled ARMED (red), STATUS (green), MEMORY (red). BFC-208/208B Remote Stations have unlabeled light indicators for Armed (red) and Status (green) and the BFC-209 Remote Station has an extra light indicator for Memory (yellow).

Use Figure 9A, B or C to connect the arming station chosen to the control center.

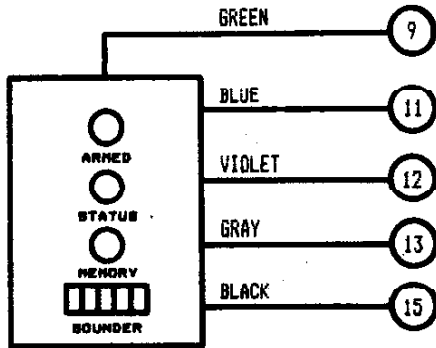

FIGURE 9A. RP-1006 KEYSWITCH STATION

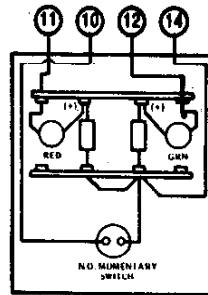

FIGURE 9B. BFC-209 KEYSWITCH STATION

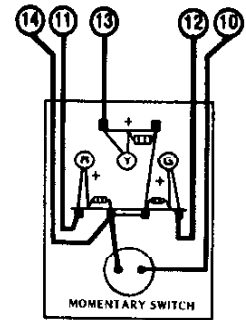

FIGURE 9C:
BFC-208 (KEYSWITCH)
BFC-208B (PUSHBUTTON)

Communicators

Any Napco tape dialer or digital communicator can be installed with the BB-5 or BB-5B. (See Ordering Information.) Connect the communicator as shown in Table 2.

CONTROL CENTER TERMINAL	COMMUNICATOR INPUT
5 (-), 9 (+)	Continuous DC Output
18 (+)	Burglary Trip
20 (+)	Fire trip

NOTE: Only one (-) connection must be made.

TABLE 2: COMMUNICATOR CONNECTIONS

Line Reversal

For control center monitoring by a central stations over leased lines, wire a Napco M-278 Line Reversal Module as shown in Figure 10A. On alarm, the module reversees normal line voltage polarity. Operation of the BELL/BATT TEST and FIRE RESET switch does not affect line reversal.

Figure 10A is used alone when connecting either Burglary or Fire, but not both. Adding the diode circuit (Figure 10B) will reverse polarity from either a burglary or fire alarm, with the same module.

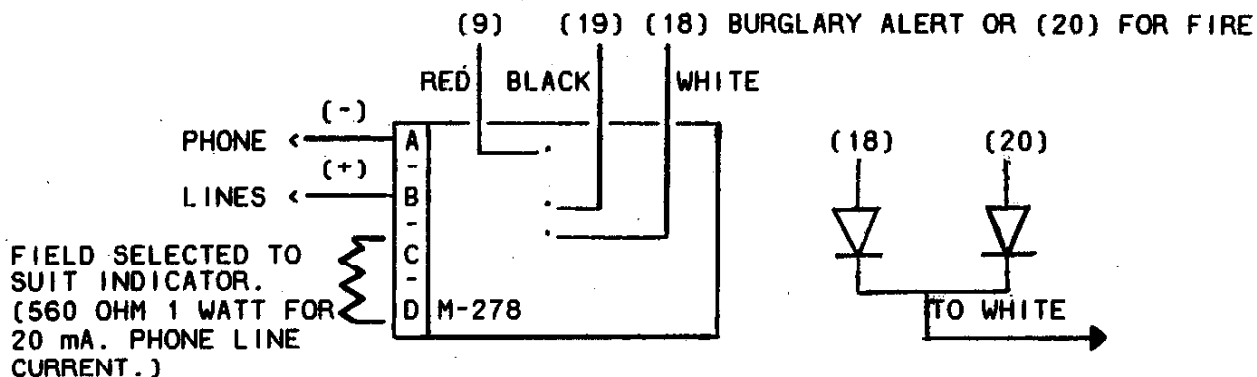

FIGURE 10A

FIGURE 10B

Siren Driver

Do not connect the siren driver common connection to any terminal other than terminal 16 (control center common). Do not wire terminal 16 to anything other than the bell or siren driver.

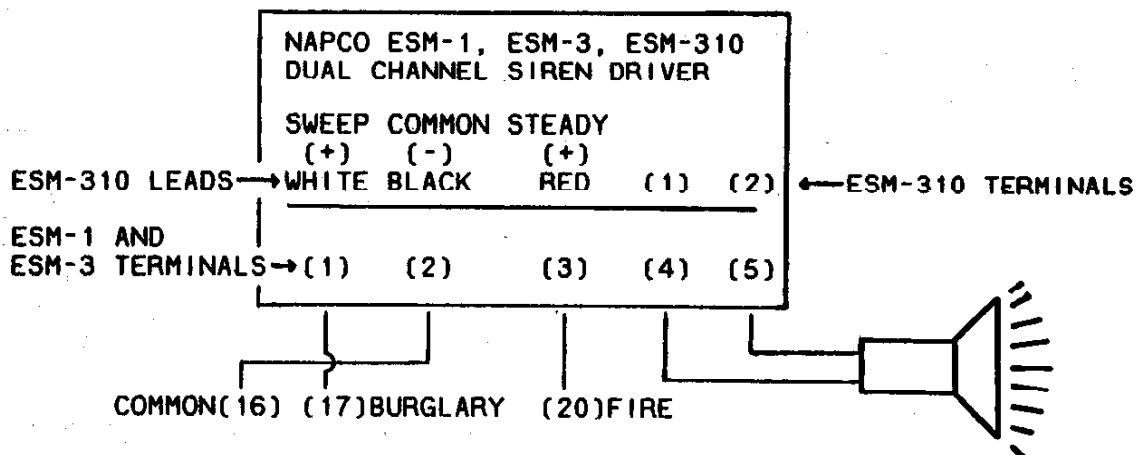

FIGURE 11. SIREN DRIVER

Fire Remote Station To monitor the fire circuit, use the BFC-213U Fire Remote Station. The BFC-213U provides remote monitoring of a supervised fire circuit, and AC power.

The red light on the station remains off unless the supervised fire circuit experiences trouble. If the fire circuit loses continuity, the red light and Mini-Sounder go on. Placing the switch on the BFC-213U in the TROUBLE position silences the sounder until the circuit is repaired. Once the source of trouble is removed, the sounder will alert the user to slide the TROUBLE switch to NORMAL.

The green light mounted on this station remains on as long as AC power is present at the control center.

Use Table 3 to wire the BFC-213U Remote Station to the control center.

Wire all fire sensors in parallel, with no branch

systems.

Figure 12A shows the connections for a fire circuit containing thermostats, but no powered detectors. Mount the 820 ohm end-of-line resistor provided with the BFC-213U as shown in the figure.

For circuits containing powered fire detectors, connect a Napco FT279 Power Loss Detector and Terminating Module in place of the 820 ohm end-of-line resistor (Figure 12B). A relay within the FT279 module is energized by the voltage supplied to the detectors. Contacts of the relay, which are connected in series with an internal end-of-line resistor, will open if the voltage is removed, breaking the supervised detector loop and causing the BFC-213U Mini-Sounder to signal.

REMOTE STATION TERMINALS	BB-5 OR BB-5B TERMINALS
1	22 FIRE CIRCUIT (+)
2	21 FIRE CIRCUIT (-)
3 AND 4	(NOT USED)
5	19 COMMON (-)
6	24 AC POWER

TABLE 3:
REMOTE STATION TO BB-5 or BB-5B

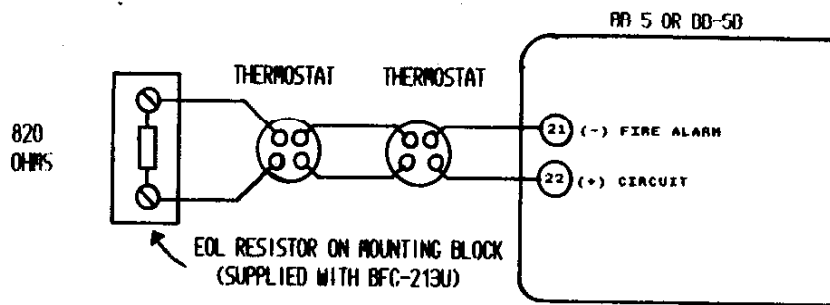

FIGURE 12A: THERMOSTAT CIRCUIT SUPERVISION

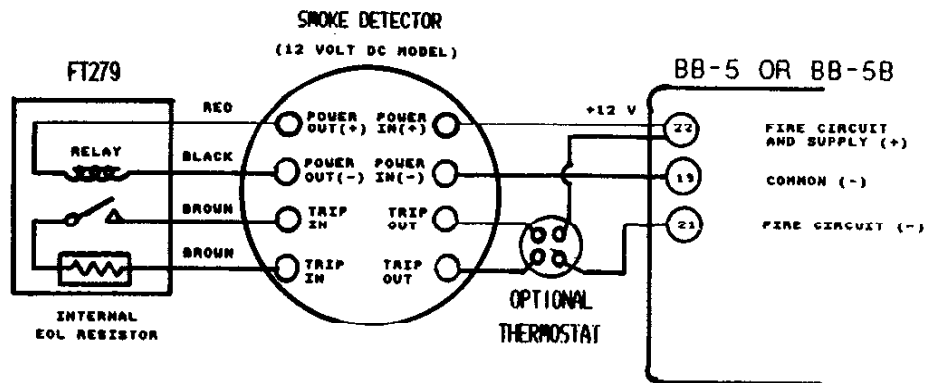

FIGURE 12B: POWERED FIRE DETECTOR CIRCUIT SUPERVISION

POWER-UP SEQUENCE

- (1) Plug transformer into wall outlet providing 24-hour continuous AC Power.
- (2) Install standby battery.
- (3) If an optional communicator is installed, connect Napco CC-403 cord to telephone company RJ31X jack.

EXIT/ENTRY DELAY TIME ADJUSTMENT

To adjust and check delay times:

- (1) Close delay circuit.
- (2) If the control center is armed, disarmed with key or keypad code.
- (3) The exit time is factory set at twice the length of the entry delay. If desired, cut the (yellow) Equal Exit & Entry Time Jumper (Figure 2) to make exit time the same as entry time.
- (4) Turn Delay Time Adjustment potentiometer (Figure 2); Rotate the adjustment wheel to the right to increase the delay time to a maximum exit time of approximately 3 minutes. Rotate to the left to decrease delay time. Rotating the adjustment wheel as far left as it will turn eliminates delay, providing almost instant activation of the circuit.
- (5) Arm. Note second hand on clock or watch.
- (6) Open delay circuit and leave it open.
- (7) Measure the seconds from the arming time to the time an alert sounds:

Mini-Sounder installed: the exit delay ends when the sound goes on (beginning of entry delay).

No Mini-Sounder: The entry delay ends when an alarm sounds. Divide this time between exit and entry delays, as follows:

Yellow jumper not cut: Divide the number of seconds measured by three. This is your entry delay time. Subtract the entry delay time from the total time. The answer is your exit delay.

Yellow jumper cut: Divide the total time before the alarm sounds by two. The answer is equal to your entry and exit delay times.

- (9) If more or less exit time is desired, return to step 1.

CONTROL CENTER OPERATION

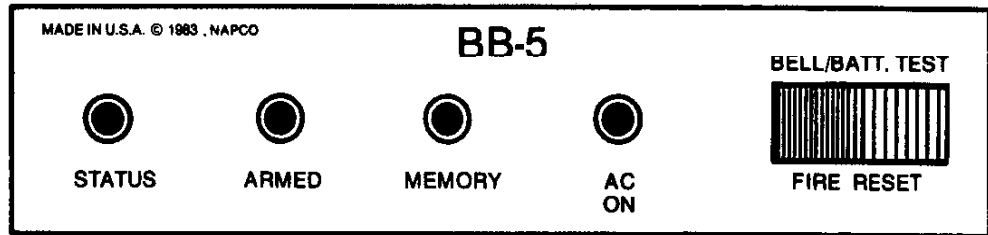

FIGURE 13: CONTROL CENTER EXTERIOR FRONT PANEL

STATUS Light (Green)

Remains on while the control center is disarmed, as long as the burglary circuits and fuses are normal.

ARMED Light (Red)

Goes on when the control center is armed.

AC ON Light (Yellow)

Remains on as long as AC power from the transformer is present at terminals 23 and 24.

MEMORY Light (Red)

Goes on when an alarm occurs. Remains on after the control center has been disarmed to indicate a service call may be needed before the system can be re-armed. Restore any circuits necessary to normal by removing alarm condition. Arm again to reset control center. The MEMORY light will go out.

BELL/BATT TEST and FIRE RESET Switch

Battery test: Press this momentary rocker switch to supply current from the standby power source to the siren or bell connected to the Burglary Alarm output. If the alarm sounds weak or does not sound at all, either the standby battery, siren or bell is suspect. Switch activation does not affect burglary communicator trip output (terminals 18 and 19).

Fire circuit reset: Press to silence fire alarm and re-arm the fire protective circuit. Pressing this switch also interrupts the switched DC voltage output between terminals 19 and 22, in order to reset latching smoke detectors.

NAPCO LIMITED WARRANTY

NAPCO SECURITY SYSTEMS, INC. (NAPCO) warrants its products to be free from manufacturing defects in materials and workmanship for fifteen months following the date of manufacture. NAPCO will, within said period, at its option, repair or replace any product failing to operate correctly without charge to the original purchaser or user.

This warranty shall not apply to any equipment, or any part thereof, which has been repaired by others, improperly installed, improperly used, abused, altered, damaged, subjected to acts of God, or on which any serial numbers have been altered, defaced or removed. Seller will not be responsible for any dismantling or reinstallation charges.

In case of defect, contact the security professional who installed and maintains your security system. NAPCO shall have no obligation under this warranty, or otherwise, if the product has been repaired by others, improperly installed, improperly used, abused, altered, damaged, subjected to accident, nuisance, flood, fire or acts of God, or on which any serial numbers have been altered, defaced or removed. NAPCO will not be responsible for any dismantling, reassembly or reinstallation charges.

In order to exercise the warranty, the product must be returned by the user or purchaser, shipping costs prepaid and insured to NAPCO. After repair or replacement, NAPCO assumes the cost of returning products under warranty.

There are no warranties, express or implied, which extend beyond the description on the face hereof. There is no express or implied warranty of merchantability or a warranty of fitness for a particular purpose. Additionally, this warranty is in lieu of all other obligations or liabilities on the part of NAPCO.

Any action for breach of warranty, including but not limited to any implied warranty of merchantability, must be brought within the six months following the end of the warranty period. In no case shall NAPCO be liable to anyone for any consequential or incidental damages for breach of this or any other warranty, express or implied, even if the loss or damage is caused by the seller's own negligence or fault.

This warranty contains the entire warranty. It is the sole warranty and any prior agreements or representations, whether oral or written, are either merged herein or are expressly cancelled. NAPCO neither assumes, nor authorizes any other person purporting to act on its behalf to modify, to change, or to assume for it, any other warranty or liability concerning its products.

In no event shall NAPCO be liable for an amount in

excess of NAPCO's original selling price of the product, for any loss or damage, whether direct, indirect, incidental, consequential, or otherwise arising out of any failure of the product. Seller's warranty, as hereinabove set forth, shall not be enlarged, diminished or affected by and no obligation or liability shall arise or grow out of Seller's rendering of technical advice or service in connection with Buyer's order of the goods furnished hereunder.

NAPCO RECOMMENDS THAT THE ENTIRE SYSTEM BE COMPLETELY TESTED WEEKLY.

Warning: Despite frequent testing, and due to, but not limited to, any or all of the following; criminal tampering, electrical or communications disruption, it is possible for the system to fail to perform as expected. NAPCO does not represent that the product/system may not be compromised or circumvented; or that the product or system will prevent any personal injury or property loss by burglary, robbery, fire or otherwise; nor that the product or system will in all cases provide adequate warning or protection. A properly installed and maintained alarm may only reduce risk of burglary, robbery, fire or otherwise but it is not insurance or a guarantee that these events will not occur. **CONSEQUENTLY, SELLER SHALL HAVE NO LIABILITY FOR ANY PERSONAL INJURY, PROPERTY DAMAGE, OR OTHER LOSS BASED ON A CLAIM THE PRODUCT FAILED TO GIVE WARNING.** Therefore, the installer should in turn advise the consumer to take any and all precautions for his or her safety including, but not limited to, fleeing the premises and calling police or fire department, in order to mitigate the possibilities of harm and/or damage.

NAPCO is not an insurer of either the property or safety of the user's family or employees, and limits its liability for any loss or damage including incidental or consequential damages to NAPCO's original selling price of the product regardless of the cause of such loss or damage. If the user wishes to protect itself to a greater extent, NAPCO will, at user's sole cost and expense, obtain an insurance policy to protect the user, supplemental to user's own policy, at a premium to be determined by NAPCO's insurer upon written notice from user by Certified Mail, Return Receipt Requested, to NAPCO's home office address, and upon payment of the annual premium cost by user.

Some states do not allow limitations on how long an implied Warranty lasts or do not allow the exclusion or limitation of incidental or consequential damages, or differentiate in their treatment of limitations of liability for ordinary or gross negligence, so the above limitations or exclusions may not apply to you. This Warranty gives you specific legal rights and you may also have other rights which vary from state to state.

Enclosed is my check/money order for \$ _____ to cover the Napco sales aids ordered on the reverse side.

NAME _____

TITLE _____

COMPANY _____

ADDRESS _____

CITY _____ STATE _____ ZIP _____

TELEPHONE _____



SALES DEPARTMENT
NAPCO SECURITY SYSTEMS, INC.
333 Bayview Avenue, Amityville,, NY 11701
(800) 645-9445 (USA) (800) 832-5688 (NY) (800) 247-4047 (CAN) Telex 510-227-9854

PLACE
STAMP
HERE

SALES DEPARTMENT
NAPCO SECURITY SYSTEMS, INC.
333 Bayview Avenue
Amityville, New York 11701

**SEND NOW FOR
YOUR NAPCO
BUSINESS
BUILDERS.**