



**NAPCO**<sup>®</sup>

333 Bayview Avenue  
Amityville, New York 11701  
For Sales and Repairs, (800) 645-9445  
For Technical Service, (800) 645-9440  
Publicly traded on NASDAQ Symbol: NSSC

# N-100

## INDOOR STAINLESS STEEL KEYPAD WIRING & PROGRAMMING INSTRUCTIONS

© NAPCO 2006

WI1492 7/06

### GENERAL DESCRIPTION

The N-100 is a self-contained access control keypad designed for indoor basic access applications. Its heavy stainless steel faceplate is designed to mount on a standard single-gang electrical box. The N-100 operates up to three outputs (two relays and 1 open-collector transistor) and can be used to trigger a door strike, an electromagnetic door lock, or any other relay-activated device. Programming is performed manually at the keypad, allowing up to 150 individual Users, each with their unique User Codes. The N-100 Series includes the rugged sealed environment N-100WP (see WI1493) and the waterproof N-100IMWP (see WI1494) mullion keypad with illuminated keys.

In a typical application, the N-100 will energize one or both relays upon the keypad entry of a valid User Code. Outputs 1 and 2 are two relays of the three contact Form C type, and Output 3 is an open collector transistor (terminal labeled "OC") that switches "on" (closes with the ground terminal) when energized. The length of time the outputs are energized (their "activation duration") can be programmed to between 1 and 99 seconds. A Request-to-Exit button will momentarily short Output 1 by wiring terminals M and P1 using a normally-open momentary-close switch.

To program the keypad functions you must first perform the initial startup procedure, then enter *Program Mode* by pressing the Master Code at the keypad. Once in Program Mode, all system functions can be accessed and programmed. Exit Program Mode to put the keypad (with its new programming) into use.

### SPECIFICATIONS

- 12 to 24VDC (polarized) or 12 to 24VAC voltage input
- Output 1: 5A/250VAC relay
- Output 2: 3A/125VAC relay
- Output 3: 250mA open collector
- Capacity of 150 User Codes of 3 to 6 digits
- Output activation duration programmable from 01-99 seconds (program "00" to select "toggle" mode)
- All programming stored in non-volatile EEPROM memory
- Orange LED Keypress feedback
- Output #1 relay activation duration programmable per user code
- Tamper switch output terminals (S1 - S2) on PCB
- Sounder "beeps" can be activated or deactivated for user code entries
- Operating Temperature: -13°F to 131°F  
-25°C to +55°C
- Dimensions (WxHxD): 3" x 4<sup>3</sup>/<sub>8</sub>" x 7<sup>7</sup>/<sub>8</sub>"  
7.6cm x 11.1cm x 2.2cm
- Operating Voltage: 12VDC to 28VDC  
10VAC to 26 VAC
- Maximum Current Draw:
  - 12VDC: 13mA (Standby) 48mA (Active)
  - 24VDC: 20mA (Standby) 58mA (Active)
  - 12VAC: 30mA (Standby) 100mA (Active)
  - 24VAC: 50mA (Standby) 121mA (Active)

**N-100 Wiring Table**

Terminal Markings	Description
+	+ 12V or 24V AC/DC Input
-	- Ground
M	Request to Exit Input
P1	Request to Exit Input
OC	Open Collector Output
NO	Relay 1 Normally Open
C1	Relay 1 Common
NC	Relay 1 Normally Closed
NO	Relay 2 Normally Open
C2	Relay 2 Common
NC	Relay 2 Normally Closed
S1	Tamper SW Output
S2	Tamper SW Output

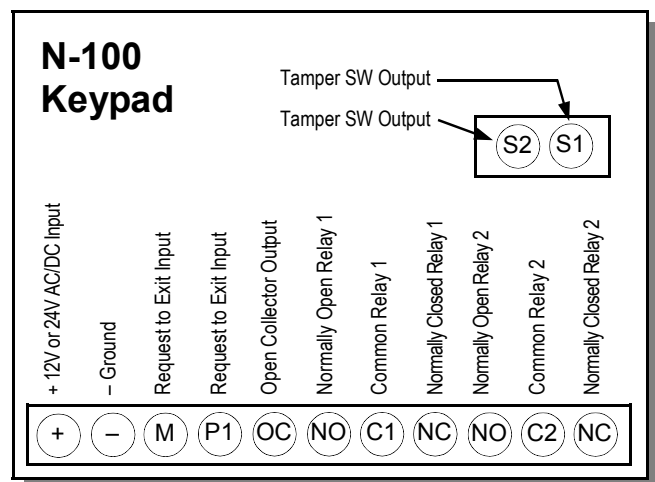

## GETTING STARTED

### First Time Startup--Self-Test

After you unpack the lock from its factory packaging, perform the initial startup procedure (outlined below). For keypads already in use, this startup procedure can also be used to erase all existing keypad programming and return the keypad back to its original "out of box" factory default condition.

1. **Install the jumper** located on the back of the keypad.
2. **Apply power** (12-24VDC polarized or 12-24VAC) to the power input terminals.
  - Orange LED blinks once
3. **Press** **7 8 9 0 # 1 2 3 4 5 6 \*** (note that keys are silent when pressed).
  - Red LED turns ON
  - Orange LED turns ON
  - Green LED turns ON
  - Green LED turns OFF
  - Each Output 1,2 & 3 activates for 1½ seconds
  - Orange LED turns OFF
  - Sounder beeps twice (memory resets and default values enabled)
4. **Close the "Request to Exit" button** (short terminals M and P1).
  - Red LED blinks
5. **Remove the jumper** on the back of the keypad.
  - Sounder beeps once
6. **Remove power** to the power input terminals.
7. **Apply power** to the power input terminals.
  - Sounder beeps once

If the keypad encounters a problem while memory is re-setting at step 3, the sounder will beep continuously until the jumper is removed and the procedure is repeated at step 1. The factory default values are detailed in the section below.

### Default Values

No pre-configured user codes exist for new "out of the box" keypads. Other default values include:

<b>User Code length</b>	4 digits
<b>Maximum Delay Between Key Presses</b>	10 seconds
<b>Auto Exit Program Mode</b>	120 seconds
<b>Factory Default Master Code</b>	1234
<b>Output Activation Duration</b>	5 seconds
<b>Sounder</b>	Always ON
<b>First Key Press Activates Output 3</b>	Inactive

### Enter Program Mode

The keypad software has only two "modes"--"Normal Mode" and "Program Mode". When you want to make changes to the keypad (enter new User Codes, etc.), you enter "Program Mode". When you finish programming and wish to put the keypad into use, you exit Program Mode to enter "Normal Mode".

- **Enter Program Mode:** Press **5 5 # 1 2 3 4 \***.

Enter Program Mode by pressing **5 5 #**, then press the *Master Code* of the lock that was set at the factory

(**1 2 3 4**), followed by the **\*** key (the orange LED lights and the sounder beeps twice).

The factory Master Code (**1 2 3 4**) is basically a secret passcode that allows you to enter Program Mode. But since all keypads leave the factory with this same Master Code, the factory Master Code is therefore not very secret--and should be changed to your own personal Master Code. This way, only YOU can enter Program Mode and make changes to the keypad programming.

### Change Factory Master Code

Although the factory Master Code can be changed at any time, for highest security, follow the procedure below:

Think of a new four-digit numeric Master Code and either commit it to memory or write it here:                    .

**Note:** Only numbers zero through 9 are valid digits for either User Codes or the Master Code. Keys **\*** or **#** are not allowed. In addition, the Master Code and all User Codes must always be the same number of digits in length (3-6 digits allowed). Therefore, if you enter Program Mode and change this "Code Length" using Function 30, you must then remain in Program Mode and change the Master Code to conform to the new "Code Length". At this point, however, we recommend you do not change the Code Length unless you are an advanced user.

1. **If not in already, enter Program Mode** (press **5 5 # 1 2 3 4 \***).
  - Orange LED lights - sounder beeps twice.
2. **Press** **3 1 #**
  - Green LED blinks once - sounder beeps once.
3. **Press new 4-digit Master Code** and press **#**.
  - Green LED blinks once - sounder beeps once.
4. **Re-press new 4-digit Master Code** and press **# \***.
  - Green LED lights / sounder beeps for 1 second indicating the Master Code was changed successfully.

The keypad remains in Program Mode while the orange LED remains lit. **Note:** The keypad will automatically exit Program Mode if no keys are pressed within 120 seconds (2 minutes).

### Adding User Codes

*User Codes* are 3-6 digit numbers the User presses into the keypad keys to activate one or more Outputs. The N-100 Series keypads can hold up to 150 User Codes in its memory, thus allowing up to 150 people to possess their own individual User Codes. The keypad memory associates each User Code with a 3-digit *User Number* listed from 000 to 149. Therefore, when adding new User Codes, you must also select a 3-digit User Number between 000 and 149 that will be associated ("linked") with the new User Code. As with the Master Code, only numbers zero through 9 are valid digits for User Codes (keys **\*** or **#** are not allowed) and each User Code must be unique.

1. **If not in already, enter Program Mode.**
  - Orange LED lights - sounder beeps twice.

2. **Press** [3] [2] [#]
  - Green LED blinks once - sounder beeps once.
3. **Press new 3-digit User Number** and press [#].
  - Green LED blinks once - sounder beeps once.
4. **Press new 4-digit User Code** and press [#].
  - Green LED blinks once - sounder beeps once.
5. **Re-press new 4-digit User Code** and press [#] [\*].
  - Green LED lights / sounder beeps for 1 second indicating the User Code was added successfully.

#### Delete a User Code

1. **If not in already, enter Program Mode.**
  - Orange LED lights - sounder beeps twice.
2. **Press** [3] [4] [#]
  - Green LED blinks once - sounder beeps once.
3. **Press the 3-digit User Number** associated with the User Code you wish to delete and press [#] [\*].
  - Green LED lights / sounder beeps for 1 second indicating the User Code was deleted successfully.

#### Exit Program Mode

When you finish programming and wish to put the keypad into use, you exit Program Mode to enter "Normal Mode" as follows:

- **Exit Program Mode:** Press [\*].

The orange LED turns off, the sounder beeps twice and the red LED lights. **Note:** The keypad will automatically exit Program Mode if no keys are pressed within 120 seconds (2 minutes).

#### Test the Keypad

Be sure to test all User Codes. Keep in mind the following:

- Valid User Codes must be followed by the star ([\*]) key
- Master Code and User Codes must all be the same length
- By default, a valid User Code always activates Output 1 unless Output selection is changed

## ALL PROGRAMMING FUNCTIONS

Your keypad is designed to support several options and functions. Using the keypad, you can select the features you wish to activate, such as if the keypad sounder should be disabled or enabled or you wish to change the code length from 4 to 6 digits..

Each function is organized below by its function number, which is the first two digits pressed into the keypad when programming. To program, first enter Program Mode as follows:

- **Enter Program Mode:** Press [5] [5] [#] [Master Code] [\*].

When you finish programming and wish to put the keypad into use, exit Program Mode to enter "Normal Mode" as follows:

- **Exit Program Mode:** Press [\*].

**Note:** The audible sounder and visual LED indicators are displayed in the text below as follows:

[O2] = Orange LED lights and sounder beeps twice

[G1] = Green LED lights and sounder beeps once

[R2] = Red LED lights and sounder beeps twice

**Note:** Every duration field is a two digit field. Master code is strictly reserved for entering Program Mode and cannot be used to activate an Output.

#### 21 Output 1 Activation Duration

Program time from 01 to 99 seconds. Program 00 to select "latch mode" where output remains activated by the entry of a valid User Code (until deactivated by the entry of a second valid User Code). **Note:** By default, a valid User Code always activates Output 1 unless Output selection is changed.

**Press:** [2] [1] [#] [G1] \_\_\_\_ [#] [\*] [G1].

#### 22 Output 2 Activation Duration

Program time from 01 to 99 seconds. Program 00 to select "latch mode" where output remains activated by the entry of a valid User Code (until deactivated by the entry of a second valid User Code).

**Press:** [2] [2] [#] [G1] \_\_\_\_ [#] [\*] [G1].

#### 23 Output 3 Activation Duration

Program time from 01 to 99 seconds. Program 00 to select "latch mode" where output remains activated by the entry of a valid User Code (until deactivated by the entry of a second valid User Code).

**Press:** [2] [3] [#] [G1] \_\_\_\_ [#] [\*] [G1].

#### 30 Code Length

Changes the number of required digits in all new User Codes and the existing Master Code. 3-6 digits are allowed, thus valid entries are "3", "4", "5" or "6". The factory default Code Length is 4.

**WARNING:** When the Code Length is changed, all existing User Codes and the Master Code become invalid. Because the Master Code and all User Codes must *always* be the same number of digits in length, if you change the Code Length with Function 30 you **MUST** remain in Program Mode and change the Master Code to conform to the new programmed "Code Length".

**Press:** [3] [0] [#] [G1] \_\_\_\_ [#] [\*] [G1].

#### 31 Modify Master Code

Changes existing Master Code. **Note:** The Master Code and all User Codes must *always* be the same number of digits in length. If changing the number of digits in the Master Code, you must first change the Code Length via Function 30 (to accommodate the new number of digits in the new Master Code) and—without exiting Program Mode—change the Master Code via Function 31.

**Press:** [3] [1] [#] [G1] (new MC) [#] [G1] (new MC) [#] [\*] [G1].

Be sure to either commit the Master Code to memory or record it in a safe place. If the Master Code is ever lost, the keypad will need to be restarted using the First Time Startup procedure described on page 2.

### 32 Add (or Edit) a User Code

Allows you to add a new or edit an existing *User Code*. User Codes are 3-6 digit numbers the User presses into the keypad keys to activate one or more Outputs. The N-100 Series keypads can hold up to 150 User Codes in its memory, thus allowing up to 150 people to possess their own individual User Codes. The keypad memory associates each User Code with a 3-digit *User Number* listed from 000 to 149. Therefore, when adding new User Codes, you must also select a 3-digit User Number between 000 and 149 that will be associated ("linked") with the new User Code. As with the Master Code, only numbers zero through 9 are valid digits for User Codes (keys \* or # are not allowed) and each User Code must be unique. Programming requires entering the new User Code twice for confirmation, as follows:

**Press:** [3] [2] [#] [G1] (User Number) [#] [G1] (User Code) [#] [G1] (re-enter User Code) [#] [\*] [G1].

### 33 Add (or Edit) a User Code with Output 1 Duration

Same as Function 32 plus the ability of the individual User Code to activate Output 1 for a specified duration (from 01 to 99 seconds). Program 00 to select "latch mode" where output remains activated by the entry of a valid User Code (until deactivated by the entry of a second valid User Code).

**Press:** [3] [3] [#] [G1] (time 01-99) [#] [G1] (User Number) [#] [G1] (User Code) [#] [G1] (re-enter User Code) [#] [\*] [G1].

### 34 Delete User Code

Overwrites specified User Number with vacant data, thus erasing the User Code from memory.

**Press:** [3] [4] [#] [G1] (User Number) [#] [\*] [G1].

### 40 Reset Keypad

Erase all existing keypad programming and return the keypad back to its original "out of box" factory default condition

**Press:** [4] [0] [#] [G1] [1] [2] [3] [4] [5] [#] [G1] [1] [2] [3] [4] [5] [#] [\*] [G1].

### 52 Add (or Edit) a User Code with Output Activation

Same as Function 32 plus the ability of the individual User Code to activate the specified Output(s).

**Press:** [5] [2] [#] [G1] (2-digits\*) [#] [G1] (User Number) [#] [G1] (User Code) [#] [G1] (re-enter User Code) [#] [\*] [G1].

\*Some examples of the "2-digits" field:

- press "12" to activate Outputs 1 and 2
- press "23" to activate Outputs 2 and 3
- press "13" to activate Outputs 1 and 3
- press "02" to activate Output 2 only
- press "10" to activate Output 1 only ...etc.

**Note:** If Function 70 ("Output 3 Activates on First Keypress") is enabled, Output 3 cannot be included in the choices offered by Function 52.

**Note:** The value in "Output 2 timer value" (from 01 to 99 seconds) is the duration of relay #2 activation when the door bell button is momentarily pressed. If the door bell activation must follow the key press action, then "Output 2 timer value" should be 00.

### 60 Sounder Beeps

Activate sounder beeping or deactivate when pressing User Codes only.

**Always ON Press:** [6] [0] [#] [G1] [1] [#] [\*] [G1].

**OFF for User Codes:** [6] [0] [#] [G1] [0] [#] [\*] [G1].

Sounder factory default is "Always ON".

### 70 Output 3 Activates on First Keypress

Enable Output 3 to activate upon any first keypress when in "Normal Mode" (such as the first keypress when entering a User Code). Output 3 is a 250mA open collector transistor output. Function 70 can be used for many purposes, such as to trigger a surveillance camera to record all activity at the keypad. In addition, Output 3 is silent, therefore Users will be unaware when Output 3 is activated. Function 70 can also be used to deactivate this feature, as follows:

**Activate Press:** [7] [0] [#] [G1] [1] [#] [\*] [G1].

**Deactivate Press:** [7] [0] [#] [G1] [0] [#] [\*] [G1].

**Note:** If Function 70 is enabled, Output 3 cannot be included in the choices offered by Function 52.

**NOTE:** This equipment has been tested and found to comply with the limits for a Class B digital device, pursuant to part 15 of the FCC Rules. These limits are designed to provide reasonable protection against harmful interference in a residential installation. This equipment generates, uses and can radiate radio frequency energy and, if not installed and used in accordance with the instructions, may cause harmful interference to radio communications. However, there is no guarantee that interference will not occur in a particular installation. If this equipment does cause harmful interference to radio or television reception, which can be determined by turning the equipment off and on, the user is encouraged to try to correct the interference by one or more of the following measures: —Reorient or relocate the receiving antenna. —Increase the separation between the equipment and receiver. —Connect the equipment into an outlet on a circuit different from that to which the receiver is connected. —Consult the dealer or an experienced radio/TV technician for help.

Audible Sounder Indicators		
Beep(s)	In Normal Mode	In Program Mode
1 short	Unit power up and when a key is pressed	Valid data confirmation
1 long	Relay activation following a valid User Code	Data recorded
2 short	Enter Program Mode	Exit Program Mode
4 short	Data error	Data Error

Visual LED Indicators		
LED	In Normal Mode	In Program Mode
Red	Remains lit while waiting for a keypress	Confirms errors Blinks when editing an existing User Number
Orange	Flashes to confirm keypress	Steady On to confirm in Program Mode. Flashes to confirm keypress
Green	Confirms activation of Outputs, memory reset and Master Code reset	Confirms valid data or empty User Number

## WIRING EXAMPLES

### ONE KEYPAD CONTROLS A DOOR

The diagram at right displays basic wiring—how to control a single door with one keypad. When you enter a valid code on Keypad 1, the magnetic lock unlocks directly. This wiring is "Fail Secure" which means that if power is lost, the door will remain locked.

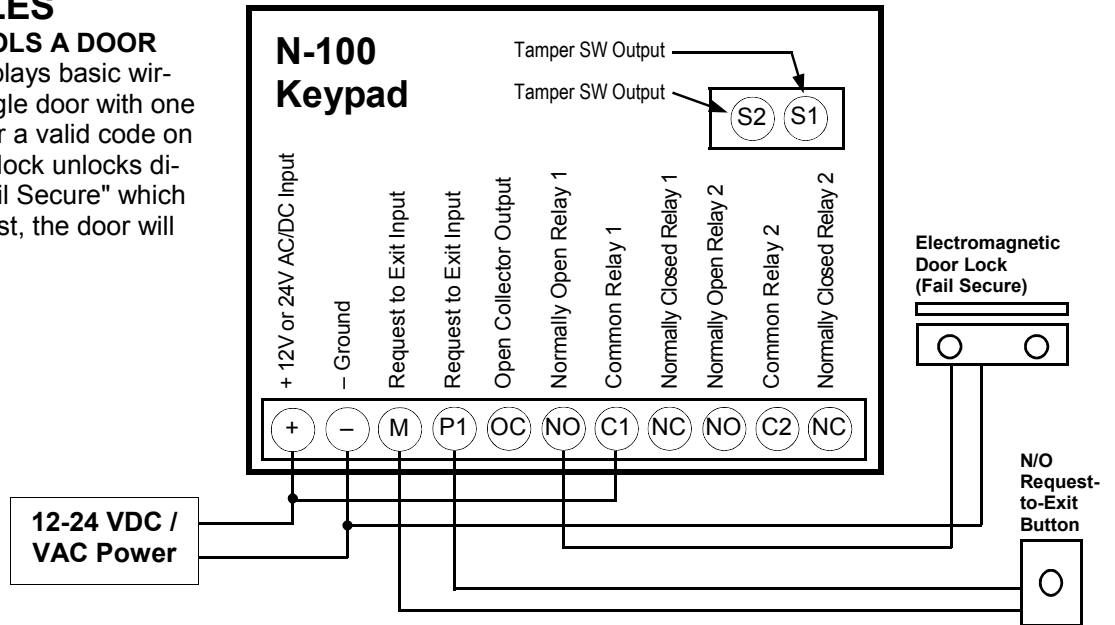

### TWO KEYPADS CONTROL ONE DOOR

The below diagram displays how to control a single door with two keypads. When you enter a valid code on Keypad 2, the magnetic lock unlocks directly. When you enter a valid code on Keypad 1, the Request-to-Exit input of keypad 2 is triggered, unlocking the door. **Note:** Valid user codes must be programmed into both Keypads 1 and 2.

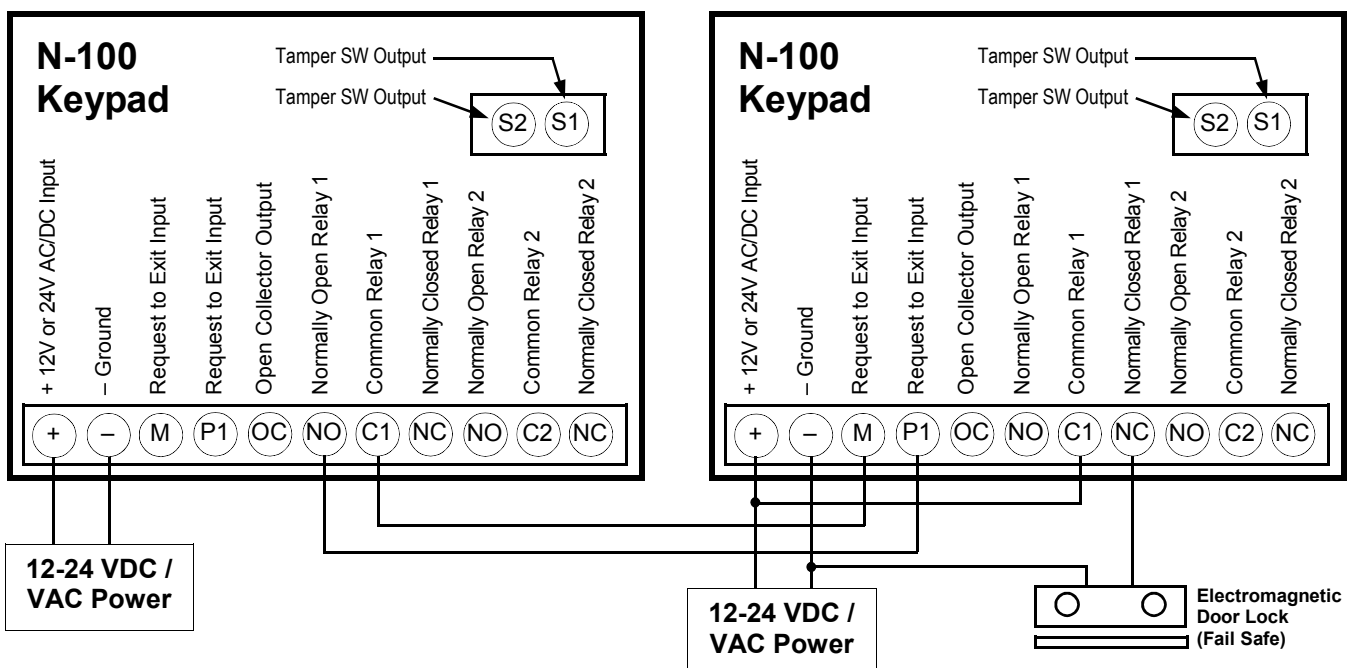

# PROGRAMMING FUNCTIONS--OVERVIEW

The audible sounder and visual LED indicators are displayed in the text below as follows:

[O2] = Orange LED lights and sounder beeps twice

[G1] = Green LED lights and sounder beeps once

[R2] = Red LED lights and sounder beeps twice

## PROGRAM MODE

FUNCTION NUMBER	DESCRIPTION	PRESS THESE BUTTONS ON KEYPAD
55	Enter Program Mode	Press <b>[5] [5] [#] [Master Code] [*]</b>
--	Exit Program Mode	Press <b>[*]</b>

## USER FUNCTIONS

FUNCTION NUMBER	DESCRIPTION	PRESS THESE BUTTONS ON KEYPAD
30	Code Length	Press: <b>[3] [0] [#] [G1] ____ [#] [*] [G1]</b> .
31	Modify Master Code	Press: <b>[3] [1] [#] [G1] (new MC) [#] [G1] (new MC) [#] [*] [G1]</b> .
32	Add (or Edit) a User Code	Press: <b>[3] [2] [#] [G1] (User Number) [#] [G1] (User Code) [#] [G1] (re-enter User Code) [#] [*] [G1]</b> .
33	Add (or Edit) a User Code with Output 1 Duration	Press: <b>[3] [3] [#] [G1] (time 01-99) [#] [G1] (User Number) [#] [G1] (User Code) [#] [G1] (re-enter User Code) [#] [*] [G1]</b> .
34	Delete User Code	Press: <b>[3] [4] [#] [G1] (User Number) [#] [*] [G1]</b> .
52	Add (or Edit) a User Code with Output Activation	Press: <b>[5] [2] [#] [G1] (2-digits) [#] [G1] (User Number) [#] [G1] (User Code) [#] [G1] (re-enter User Code) [#] [*] [G1]</b> .

## TIMER FUNCTIONS

FUNCTION NUMBER	DESCRIPTION	PRESS THESE BUTTONS ON KEYPAD
21	Output 1 Activation Duration	Program time from 01 to 99 seconds. Press: <b>[2] [1] [#] [G1] ____ [#] [*] [G1]</b> .
22	Output 2 Activation Duration	Program time from 01 to 99 seconds. Press: <b>[2] [2] [#] [G1] ____ [#] [*] [G1]</b> .
23	Output 3 Activation Duration	Program time from 01 to 99 seconds. Press: <b>[2] [3] [#] [G1] ____ [#] [*] [G1]</b> .

## SYSTEM FUNCTIONS

FUNCTION NUMBER	DESCRIPTION	PRESS THESE BUTTONS ON KEYPAD
40	Reset Keypad	Press: <b>[4] [0] [#] [G1] [1] [2] [3] [4] [5] [#] [G1] [1] [2] [3] [4] [5] [#] [*] [G1]</b> .
60	Sounder Beeps	Always ON Press: <b>[6] [0] [#] [G1] [1] [#] [*] [G1]</b> . OFF for User Codes: <b>[6] [0] [#] [G1] [0] [#] [*] [G1]</b> .
70	Output 3 Activates on First Keypress	Activate Press: <b>[7] [0] [#] [G1] [1] [#] [*] [G1]</b> . Deactivate Press: <b>[7] [0] [#] [G1] [0] [#] [*] [G1]</b> .

# MOUNTING TEMPLATE

The N-100 is designed to be installed in a single-gang box. The mounting screws are  $3\frac{1}{4}$ " apart.

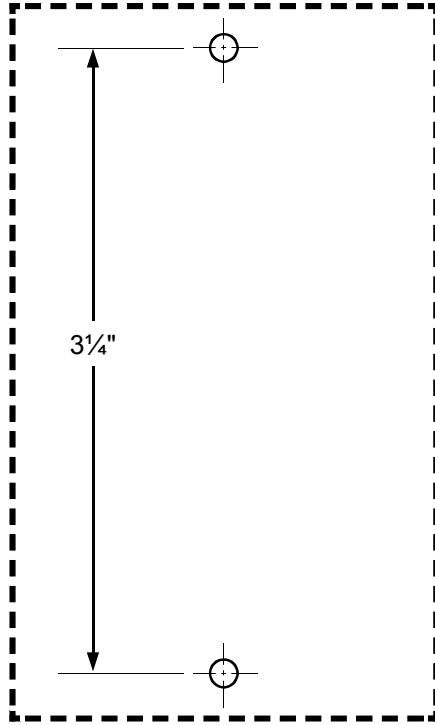

## NAPCO LIMITED WARRANTY

NAPCO SECURITY SYSTEMS, INC. (NAPCO) warrants its products to be free from manufacturing defects in materials and workmanship for thirty-six months following the date of manufacture. NAPCO will, within said period, at its option, repair or replace any product failing to operate correctly without charge to the original purchaser or user.

This warranty shall not apply to any equipment, or any part thereof, which has been repaired by others, improperly installed, improperly used, abused, altered, damaged, subjected to acts of God, or on which any serial numbers have been altered, defaced or removed. Seller will not be responsible for any dismantling or reinstallation charges.

THERE ARE NO WARRANTIES, EXPRESS OR IMPLIED, WHICH EXTEND BEYOND THE DESCRIPTION ON THE FACE HEREOF. THERE IS NO EXPRESS OR IMPLIED WARRANTY OF MERCHANTABILITY OR A WARRANTY OF FITNESS FOR A PARTICULAR PURPOSE. ADDITIONALLY, THIS WARRANTY IS IN LIEU OF ALL OTHER OBLIGATIONS OR LIABILITIES ON THE PART OF NAPCO.

Any action for breach of warranty, including but not limited to any implied warranty of merchantability, must be brought within the six months following the end of the warranty period. IN NO CASE SHALL NAPCO BE LIABLE TO ANYONE FOR ANY CONSEQUENTIAL OR INCIDENTAL DAMAGES FOR BREACH OF THIS OR ANY OTHER WARRANTY, EXPRESS OR IMPLIED, EVEN IF THE LOSS OR DAMAGE IS CAUSED BY THE SELLER'S OWN NEGLIGENCE OR FAULT.

In case of defect, contact the security professional who installed and maintains your security system. In order to exercise the warranty, the product must be returned by the security professional, shipping costs prepaid and insured to NAPCO. After repair or replacement, NAPCO assumes the cost of returning products under warranty. NAPCO shall have no obligation under this warranty, or otherwise, if the product has been repaired by others, improperly installed, improperly used, abused, altered, damaged, subjected to accident, nuisance, flood, fire or acts of God, or on which any serial numbers have been altered, defaced or removed. NAPCO will not be responsible for any dismantling, re-assembly or reinstallation charges.

**This warranty contains the entire warranty. It is the sole warranty and any prior agreements or representations, whether oral or written, are either merged herein or are expressly cancelled. NAPCO neither assumes, nor authorizes any other person purporting to act on its behalf to modify, to**

**change, or to assume for it, any other warranty or liability concerning its products.**

In no event shall NAPCO be liable for an amount in excess of NAPCO's original selling price of the product, for any loss or damage, whether direct, indirect, incidental, consequential, or otherwise arising out of any failure of the product. Seller's warranty, as hereinabove set forth, shall not be enlarged, diminished or affected by and no obligation or liability shall arise or grow out of Seller's rendering of technical advice or service in connection with Buyer's order of the goods furnished hereunder.

NAPCO RECOMMENDS THAT THE ENTIRE SYSTEM BE COMPLETELY TESTED WEEKLY.

**Warning:** Despite frequent testing, and due to, but not limited to, any or all of the following; criminal tampering, electrical or communications disruption, it is possible for the system to fail to perform as expected. NAPCO does not represent that the product/system may not be compromised or circumvented; or that the product or system will prevent any personal injury or property loss by burglary, robbery, fire or otherwise; nor that the product or system will in all cases provide adequate warning or protection. A properly installed and maintained alarm may only reduce risk of burglary, robbery, fire or otherwise but it is not insurance or a guarantee that these events will not occur. CONSEQUENTLY, SELLER SHALL HAVE NO LIABILITY FOR ANY PERSONAL INJURY, PROPERTY DAMAGE, OR OTHER LOSS BASED ON A CLAIM THE PRODUCT FAILED TO GIVE WARNING. Therefore, the installer should in turn advise the consumer to take any and all precautions for his or her safety including, but not limited to, fleeing the premises and calling police or fire department, in order to mitigate the possibilities of harm and/or damage.

NAPCO is not an insurer of either the property or safety of the user's family or employees, and limits its liability for any loss or damage including incidental or consequential damages to NAPCO's original selling price of the product regardless of the cause of such loss or damage.

Some states do not allow limitations on how long an implied warranty lasts or do not allow the exclusion or limitation of incidental or consequential damages, or differentiate in their treatment of limitations of liability for ordinary or gross negligence, so the above limitations or exclusions may not apply to you. This Warranty gives you specific legal rights and you may also have other rights which vary from state to state.