

# ***XL-4, XL-4B, XL-5 Security System***

---

---

## ***Installation and Setup Guide***

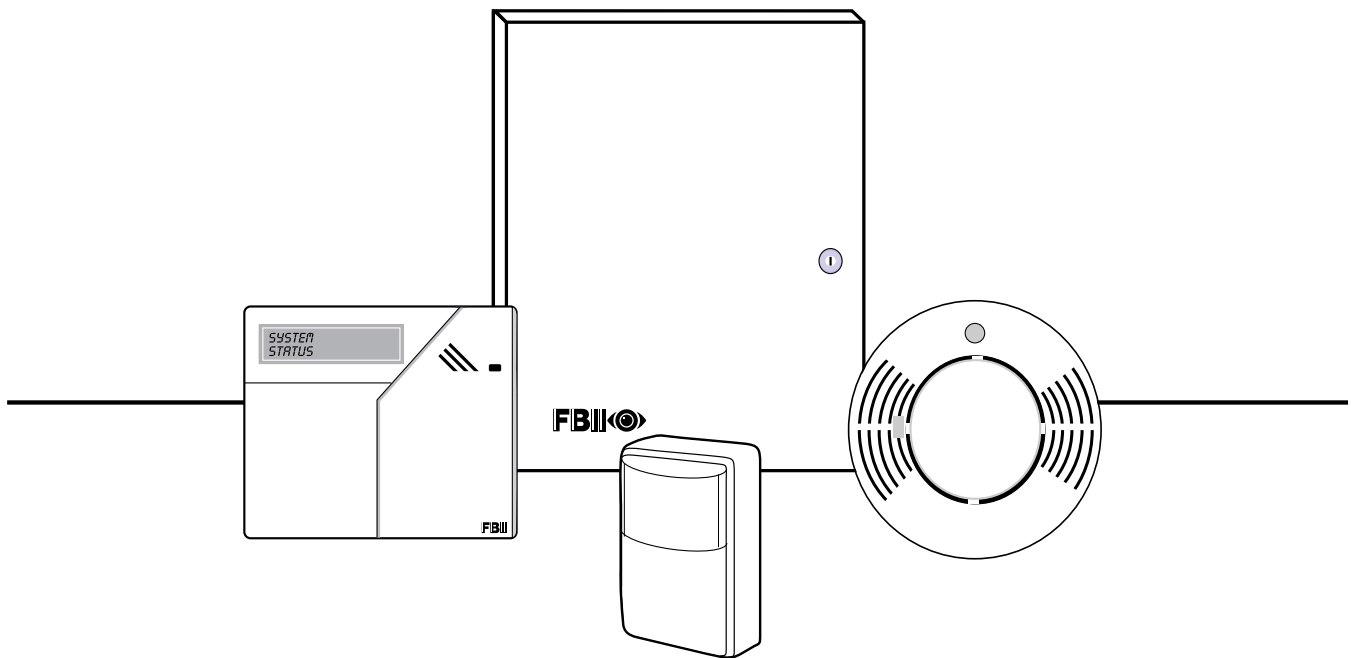

***Version 4***

---

---

# Table of Contents

<b>Conventions Used in This Manual</b> .....	<b>iv</b>
<b>Section 1 - Introduction</b> .....	<b>1-1</b>
General.....	1-1
UL Listings .....	1-2
How To Use This Manual .....	1-2
Related Documentation .....	1-2
<b>Section 2 - System Components</b> .....	<b>2-1</b>
Control Panels .....	2-1
Keypads.....	2-1
Expansion Modules .....	2-1
Accessories.....	2-1
Multiplex Peripherals .....	2-2
<b>Section 3 - System Wiring And Hookup</b> .....	<b>3-1</b>
Wiring Diagram.....	3-2
Zone Hookup.....	3-4
Hardwired Zone Expander (Optional) .....	3-4
Multiplex Zone Expander .....	3-5
Keypad Connections.....	3-6
Auxiliary Power .....	3-8
Programmer Connection.....	3-8
JP1.....	3-8
JP2.....	3-9
Default Reset .....	3-9
Panel Reset .....	3-9
Local Printer Connection.....	3-9
Line Seizure.....	3-9
Ground .....	3-9
Telephone Line .....	3-9
Tamper Switch .....	3-10
Relay #1.....	3-10
Relay #2 [Smoke Detector Power Reset].....	3-11
Trigger Connector .....	3-12
Transformer .....	3-13
Battery Backup.....	3-13
Keypad Mounting.....	3-13
<b>Section 4 - Multiplex Polling Loop</b> .....	<b>4-1</b>
Multiplex Expander Installation.....	4-1
Polling Loop Overview .....	4-2
<b>Section 5 - System Operations</b> .....	<b>5-1</b>
Keypad Layout .....	5-1
Sample LCD Display.....	5-4
Keypad Function Keys .....	5-4
Arming The System.....	5-4
STAY .....	5-6
Auto Stay .....	5-6
INSTANT.....	5-6
Instant-Stay.....	5-7
Bypass .....	5-7
Forced Arming.....	5-8
Unbypass.....	5-8
Groups.....	5-9
Group Bypass.....	5-9

## ***Table of Contents (cont'd)***

Group Unbypass.....	5-10
User Programming.....	5-10
User Deletion.....	5-11
Disarming.....	5-12
Keypad Auxiliary Conditions.....	5-12
Duress/Ambush.....	5-13
LCD Keypad Programming Mode.....	5-13
Quick Commands.....	5-13
Log Dump Function.....	5-17
Keypad Function Summary.....	5-18
<b>Section 6 - Installer Functions.....</b>	<b>6-1</b>
Keypad Programming.....	6-1
Time Date Setup.....	6-1
Walk Test.....	6-2
Walk Test With Bell Output.....	6-3
Default Reset.....	6-3
System Log View.....	6-3
<b>Index.....</b>	<b>I-1</b>

# Conventions Used in This Manual

Before you begin using this manual, it is important that you understand the meaning of the following symbols (icons).

---

**UL**

These notes include specific information that must be followed if you are installing this system for a UL Listed application.

---



These notes include information that you should be aware of before continuing with the installation, and which, if not observed, could result in operational difficulties.

---



This symbol indicates a critical note that could seriously affect the operation of the system, or could cause damage to the system. Please read each warning carefully. This symbol also denotes warnings about physical harm to the user.

---

ON: AWAY . . . . .  
... Exit now ...

In the text of this manual, LCD Keypad messages are shown in a single-line box.

# Introduction

---

## In This Section

- ◆ General
  - ◆ UL Listings
  - ◆ How To Use This Manual
  - ◆ Related Documentation
- 

## General

The XL-4 and XL-5 Series Control-Communicators are fully programmable devices with remote communication and control capabilities. Each control contains 8 hardwired zones located on the main control panel with multiplex and hardwired expansion capabilities. The expansion options include:

- 8 zone hardwire expansion (through 7105 module), providing a total of 16 hardwired zones, or
- XL-4 Multiplex polling loop expansion (through 7120 module), providing two wire multiplex loop of 64 zones (total system capacity of 72 zones)
- XL-5 Multiplex polling loop expansion (through 7126 module), providing two wire multiplex loop of 120 zones (total system capacity of 128 zones)

The system can also be setup in a partitioned configuration. Partitioning allows the control to look like as many as eight different protected locations to the Central Station. Each partition will be assigned zones, users and keypads. The account numbers transmitted for each partition are definable. Partitions can be setup to protect different functional areas of the same location (example, office area vs. warehouse) or different premises within close proximity (example, shopping center or multifamily complex).

## UL

---

If a partitioned or double area installation is configured, UL requires that the following installation requirements be observed.

1. All partitions or areas *must be* owned and managed by the same person(s).
  2. All partitions or areas *must be* part of one building at one street address.
  3. The audible alarm device(s) *must be* placed where it/they can be heard in all partitions or areas.
  4. The control cabinet itself *must be* tamper protected and connected to a 24-hour type zone so that any unauthorized access to the control cabinet will cause an alarm.
- 

The system also contains an event log that stores the past 128 events in time stamped order. This event log can be viewed by the installer through a LCD keypad, retrieved remotely from the PC Downloading software or automatically transmitted to a remote or local printer at a specified time.

Programming of the control can be accomplished either through the LCD keypad locally, or remotely from the Alarm Company location using the EZ-MATE PC Based Downloader. In addition, remote operations can be performed.



Failure to connect and program the control unit as described in this manual is a violation of the Listing Mark. Programming requirements are contained in the LCD Keypad Programming Guide.

## UL Listings

The XL-4 is the Residential (Household) version of the has been listed by Underwriters Laboratories for the following applications:

- UL 1023 Household Burglar
- UL 985 Household Fire Warning

The model XL-4B is the Commercial Burglary configuration of the control panel and has been listed by Underwriters Laboratories for the following applications:

- UL 365 Police Connected Burglar (Grade A Mercantile, Grade B)
- UL 609 Local Burglar (Grade A Mercantile, Grade B)
- UL 1610 Central Station Burglar (Grade B, Grade C)
- UL 1635 Digital Burglar

## How To Use This Manual

The Installation and Setup Guide has been organized into the following sections:

**Section 1: Introduction** – Describes the basic features and capabilities of the control and explains the sections of the Installation Instructions.

**Section 2: System Components** – Specifies the components and accessories available with the system.

**Section 3: System Hookup And Wiring** – Wiring diagram and installation instructions for the control panel.

**Section 4: Multiplex Polling Loop** – Describes the functions of the multiplex polling loop.

**Section 5. System Operations** – Describes the operational procedures as performed through the LCD and LED keypads.

**Section 6. Installer Functions** – Defines the keypad commands reserved for installers during the installation and troubleshooting of the control panel.

## Related Documentation

### XL-4, XL-4B, and XL-5 LCD Keypad Programming Guide

Detailed manual describing the complete programming of a control through the LCD keypad. This manual describes and explains all of the programmable parameters of the system.

### User Guide

Booklet designed for the end user to describe how to use the system. This manual covers both the LED and LCD keypads.

# System Components

## In This Section

- ◆ *Control Panels*
- ◆ *Keypads*
- ◆ *Expansion Modules*
- ◆ *Accessories*
- ◆ *Multiplex Peripherals*

## Control Panels

- XL-4 Includes 8 zone control/communicator and transformer. Household Burglary and Fire version of the XL-4 system. Keypads available separately.
- XL-4B XL-4 for UL Mercantile Applications. Contains control panel, transformer, and attack proof enclosure suitable for UL commercial installations. Keypads available separately.
- XL-5LT 8 zone control/communicator, less transformer. Keypads available separately.

## Keypads

- XK-7LC LCD Keypad, two line by sixteen-character English language display. Up to 8
- XK-5LC LCD keypads can be used per system.
- XK-716 LED Keypad with separate zone indicator lights. Up to 8 LED keypads can be
- XK-516 used per system. Note: This keypad can only be used in systems with zone numbers less than 16.

## Expansion Modules

- 7105 Zone Expander. Plug in module provides an additional eight hardwired zones for the XL-4 and XL-5.
- 7120 XL-4 Multiplex Expansion Module. Plug in module provides expansion capability of 64 zones on two-wire polling loop bus.
- 7126 XL-5 Multiplex Expansion Module. Plug in module provides expansion capability of 120 zones on two-wire polling loop bus.
- 7130 Serial Interface Module. Used to connect a serial printer (300-Baud) for the purpose of outputting the system log to a local serial printer.

## Accessories

- 7103UL Trigger cable assembly to interface to the controls voltage level trigger outputs.
- 7700 EZ-Mate PC Downloader. Software written for IBM or compatible personal computers (requires a hard drive) and a Hayes 1200 Smartmodem or Hayes Optima 33.6 External modem (configured as 2400) with a 7702 interface. Provides database maintenance and remote communications with the control. Note: The downloading software has not been investigated by Underwriters Laboratories Inc.

## **Multiplex Peripherals**

XL-4701	Single Point Multiplex Interface.
XL-4702	2 Point Multiplex Adapter Module that allows two conventional alarm sensing devices to be connected to the multiplex bus.
XL-4708	8 Point Multiplex Adapter Module. Used to interface 8 conventional sensing devices to the multiplex bus. Each point will contain a unique address.
XL-4722	Dual Element Passive with built in multiplex point.
XL-4750SDT	Smoke Detector with built in multiplex point.
ZR-745MSL	Recessed Contact with RPM.
ZR-750MOH	Multiplex Overhead Door Contact.
ZR-795MR	Recessed Multiplex Contact.



---

The controls multiplex capability will ONLY operate with Fire Burglary Instruments multiplex accessories.

A ZR-700P Programmer Multiplex Contacts is needed to program the multiplex address for the XL-4701, ZR-745MSL, ZR-750MOH, and ZR-795MR.

---

XL-4705 Relay Module. Each XL-4705 relay module contains 5 relays that may be used by the system alarm types. Each relay has a unique address selected by Dip switch settings within the XL-4705 Relay Module.

# System Wiring And Hookup

**In This Section**

- ◆ *Wiring Diagram*
- ◆ *Zone Hookup*
- ◆ *Hardwired Zone Expander*
- ◆ *Multiplex Zone Expander*
- ◆ *Keypad Connections*
- ◆ *Auxiliary Power*
- ◆ *Programmer Connector*
- ◆ *JP1*
- ◆ *JP2*
- ◆ *Default Reset*
- ◆ *Panel Reset*
- ◆ *Ground Start*
- ◆ *Line Seizure*
- ◆ *Ground*
- ◆ *Telephone Line*
- ◆ *Tamper Switch*
- ◆ *Relay #1*
- ◆ *Relay #2*
- ◆ *Trigger Connection*
- ◆ *Transformer*
- ◆ *Battery Backup*
- ◆ *Keypad Mounting*

Wiring Diagram

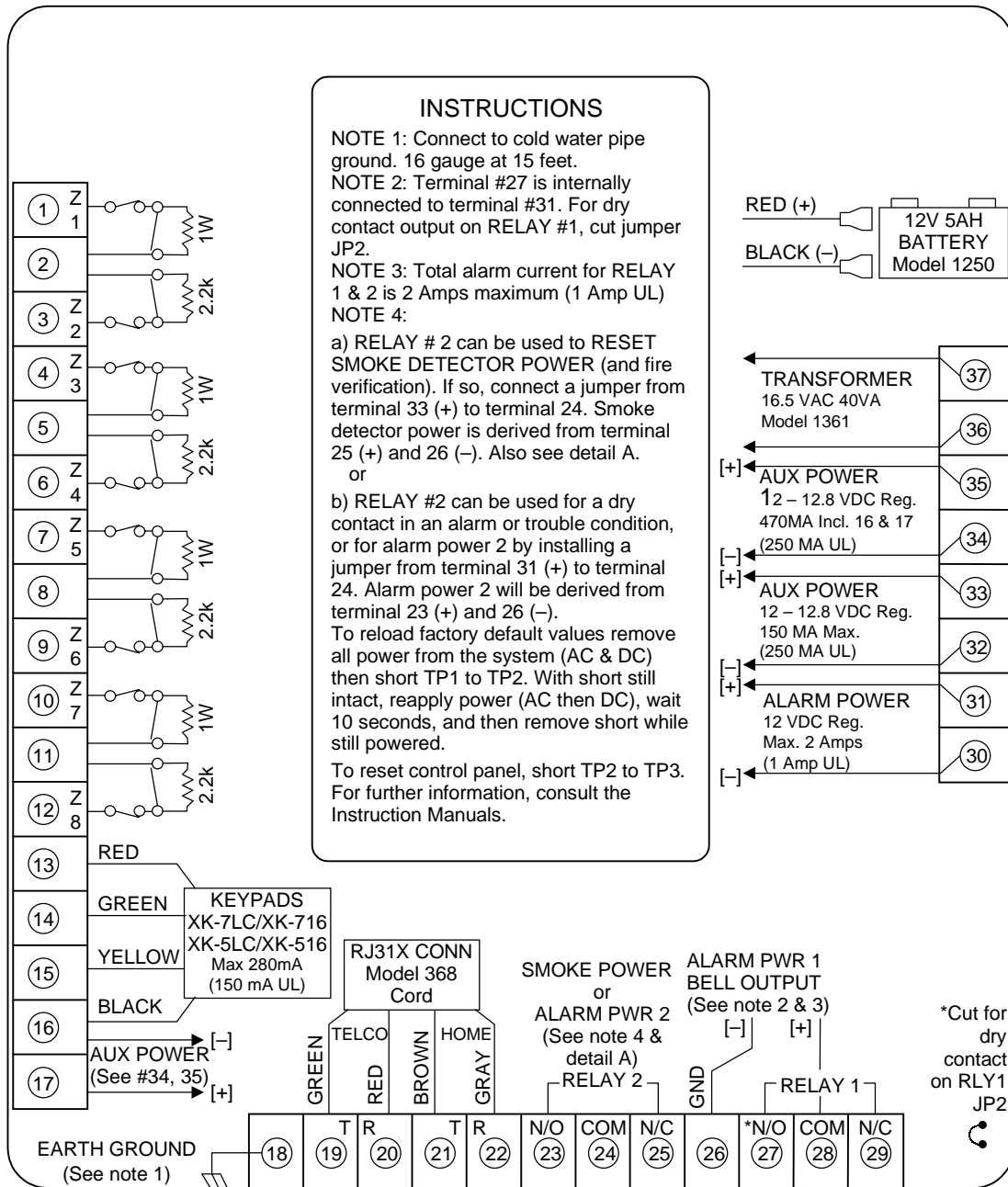

### XL-4 and XL-5 CONNECTIONS FOR HOUSEHOLD FIRE/BURGLAR ALARM SYSTEMS UL985 AND 1023

**NOTES: For UL Installation (Household)**

- 1- Connect to a grounded cold water pipe, 16 ga. at 15 feet.
- 2- Total AUX. Power available is 750 mA, which includes keypad power and expansion boards when using a 5AH battery.
- 3- System must be tested on a weekly basis. For information refer to references (N9144 & N9146, dated 7/92).
- 4- Do not connect the transformer to a receptacle controlled by a switch.
- 5- Installation of equipment and wiring methods are required to be in accordance with the National Electricians code and ANSI/NFPA no 74. More information may be obtained from the NFPA, Battery March Park, Quincy, MA 02269.
- 6- Battery capacity for Emergency Standby is a minimum of 4 hours. Under normal conditions this battery will last 3 years, use only exact replacements.
- 7- Maximum entrance time is 45 seconds, maximum exit time is 60 seconds.
- 8- Maximum of four keypads.
- 9- Expansion Modules: Model 7015 8 zone hardwire or 7120 (XL-4) /7126 (XL-5) Multiplex module.
- 10- Limited energy cable must be used.

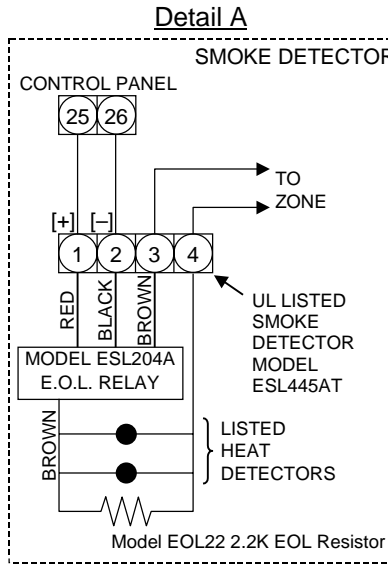

**WARNING**  
DISCONNECT PHONE LINES PRIOR TO SERVICING.

**WARNING**  
THIS UNIT INCLUDES AN ALARM VERIFICATION FEATURE THAT WILL RESULT IN A DELAY OF THE SYSTEM ALARM SIGNAL FROM THE INDICATED CIRCUITS. THE TOTAL DELAY (CONTROL UNIT PLUS SMOKE DETECTOR SHALL NOT EXCEED 60 S. NO OTHER INITIATING DEVICES SHALL BE CONNECTED TO THESE CIRCUITS UNLESS APPROVED BY THE LOCAL AUTHORITY HAVING JURISDICTION.

CIRCUIT (ZONE)	CONTROL UNIT DELAY - SEC.	SMOKE DETECTOR MODEL	DELAY - SEC*
	20		

\*Obtain from smoke detector installation instructions.

**NOTE:** For installations containing multiple smoke detectors, break the wire to maintain supervision.

**CAUTION:**  
Incorrect connections may result in damage to the unit.

### XL-4B CONNECTIONS FOR HOUSEHOLD FIRE/BURGLAR ALARM SYSTEMS UL985 AND 1023

**NOTES: For UL Installation (Household)**

- 1- Connect to a grounded cold water pipe, 16 ga. at 15 feet.
- 2- Total AUX. Power available is 750 mA, which includes keypad power and expansion boards when using a 5AH battery.
- 3- System must be tested on a weekly basis. For information refer to references (N9144 & N9146, dated 7/92).
- 4- Do not connect the transformer to a receptacle controlled by a switch.
- 5- Installation of equipment and wiring methods are required to be in accordance with the National Electricians code and ANSI/NFPA no 74. More information may be obtained from the NFPA, Battery March Park, Quincy, MA 02269.
- 6- Battery capacity for Emergency Standby is a minimum of 4 hours. Under normal conditions this battery will last 3 years, use only exact replacements.
- 7- Maximum entrance time is 45 seconds, maximum exit time is 60 seconds.
- 8- Maximum of four keypads.
- 9- Expansion Modules: Model 7015 8 zone hardwire, or 7120 Multiplex module.
- 10- Limited energy cable must be used.

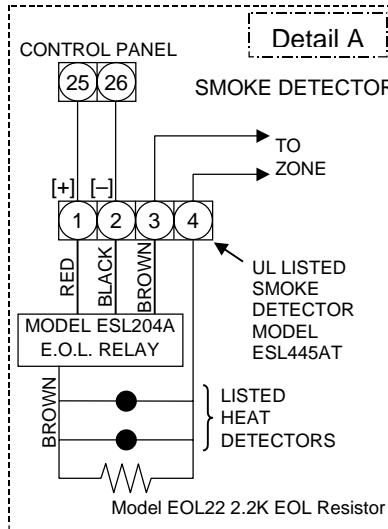

**WARNING**  
DISCONNECT PHONE LINES PRIOR TO SERVICING.

**WARNING**  
THIS UNIT INCLUDES AN ALARM VERIFICATION FEATURE THAT WILL RESULT IN A DELAY OF THE SYSTEM ALARM SIGNAL FROM THE INDICATED CIRCUITS. THE TOTAL DELAY (CONTROL UNIT PLUS SMOKE DETECTOR SHALL NOT EXCEED 60 S. NO OTHER INITIATING DEVICES SHALL BE CONNECTED TO THESE CIRCUITS UNLESS APPROVED BY THE LOCAL AUTHORITY HAVING JURISDICTION.

CIRCUIT (ZONE)	CONTROL UNIT DELAY - SEC.	SMOKE DETECTOR MODEL	DELAY - SEC*
	20		

\*Obtain from smoke detector installation instructions.

**NOTE:** For installations containing multiple smoke detectors, break the wire to maintain supervision.

**CAUTION:**  
Incorrect connections may result in damage to the unit.

### CONNECTIONS FOR MERCHANTILE BURGLAR ALARM SYSTEM UL 365, 609, AND 1635 (NOTE: All other connections are the same as above.) FOR ADDITIONAL INFORMATION REFER TO UL611 an UL681

**NOTES: For UL Installation (MERCANTILE)**

- 1- Installation of equipment and wiring methods shall be accomplished in accordance with the National Electrical Code and ANSI/NFPA no. 70.
- 2- Fire Zones shall not be employed in a Commercial application.
- 3- Maximum entrance time is 15 seconds, maximum exit time is 60 seconds.
- 4- For UL certified installations, this product shall be connected to a compatible listed Digital Alarm Receiver.
- 5- Installation requires circuit board enclosure tamper. Use either AMSECO type ATS-1 or ADEMCO No. 19, closed circuit tamper switch. Mount using the three holes provided on the side of the enclosure.
- 6- The cover of the enclosure must be secured with the eleven 1/2" long No. 8-32 screws provided.
- 7- Metal conduit shall be used to connect the bell to the control panel.
- 8- This control unit is intended for use as a Household Fire & Burglary Warning System Control Unit, Grade A Local Alarm Unit, Grade A Police Station Connected Unit with basic line security, and Grade B Central Station Burglar Alarm Unit with compatible bell, or Grade C Central Station Burglar Alarm Unit without compatible bell.

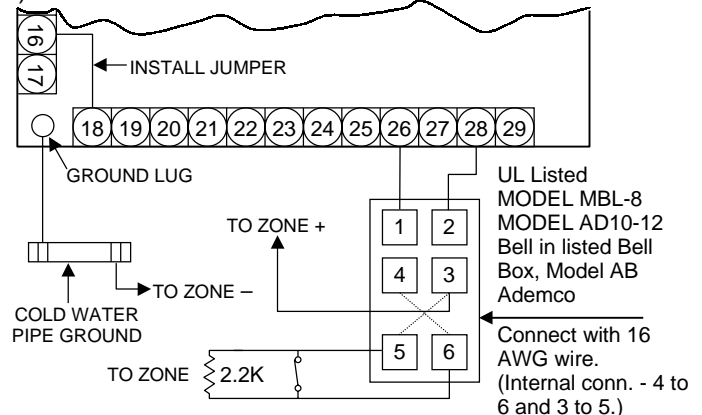

## Zone Hookup

The first eight zones are connected to T1 through T12 on the main circuit board as follows:

Zone 1	Terminal 1 & 2 (-)
Zone 2	Terminal 3 & 2 (-)
Zone 3	Terminal 4 & 5 (-)
Zone 4	Terminal 6 & 5 (-)
Zone 5	Terminal 7 & 8 (-)
Zone 6	Terminal 9 & 8 (-)
Zone 7	Terminal 10 & 11 (-)
Zone 8	Terminal 12 & 11 (-)

Control panel zones on the main circuit board and through the zone expander should be supervised using the 2.2K end of line resistors supplied.



Fire zones must use Listed part number EOL22 end of line resistors.

## Hardwired Zone Expander (Optional)

The optional Zone Expander Module model 7105 provides an additional eight zones to the control panel. Note: Either the 7105 expander, the 7120 expander (XL-4), or the 7126 expander (XL-5) can be installed in the control panel. The 7105 zone expander can be installed as follows:

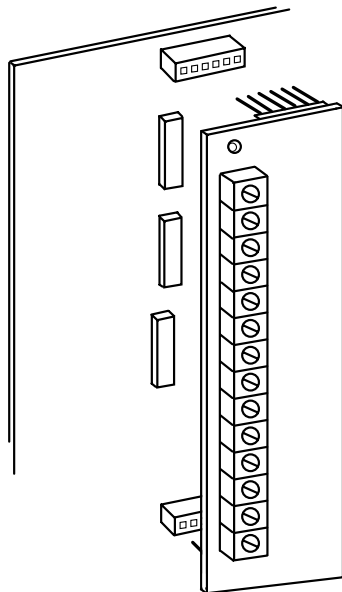

1- Remove all power from the control panel.

2- Attach the three plastic support mounting pieces to the zone expander module in the three holes located on the printed circuit board.

3- Attach the zone expander to the control panel board through the plug in connections located to the left of the wiring diagram. Carefully align the six pins on the top and bottom of the mounting connectors. Press down firmly on the expander board to insure that the board is secure in both connectors.

Note: In order for the control panel to recognize the zone expander the appropriate programming option enabling the 8-zone expander must be turned on. This can be accomplished through the LCD keypad programming sequence or the EZ-Mate PC Downloader. The second eight zones are connected to T38 through T49 on the zone expander as follows:

Zone 9	Terminal 38 & 39
Zone 10	Terminal 39 & 40
Zone 11	Terminal 41 & 42
Zone 12	Terminal 42 & 43
Zone 13	Terminal 44 & 45
Zone 14	Terminal 45 & 46
Zone 15	Terminal 47 & 48
Zone 16	Terminal 48 & 49

## Multiplex Zone Expander

The 7120 or 7126 Multiplex expander module provides multiplex loop expansion to the control panel. Each multiplex loop consists of a two-wire hookup that transmits power and data from the control panel to the multiplex accessories. The multiplex expander can be installed as follows:

- 1- Remove all power from the control panel.
- 2- Attach the three plastic support mounting pieces to the multiplex expander module in the three holes located on the printed circuit board of the multiplex expander. Place the pointed end through the bottom of the multiplex expander.
- 3- Attach the multiplex expander to the control panel through the plug in connections located to the left of the wiring diagram. Carefully align the six pins on the top and bottom of the mounting connectors. Press down firmly on the expander board to insure that the board is secure in both connectors.



In order for the control panel recognize the multiplex expander the programming option enabling multiplex operation must be turned on. This can be performed through the keypad programming sequence or through the EZ-Mate PC Downloading software. Consult the appropriate manuals to determine the method to enable the multiplex capability.

The multiplex bus can be connected as follows:

MULTIPLEX BUS LOOP NUMBER/POLARITY	7120 MULTIPLEX ZONE EXPANDER	7126 MULTIPLEX ZONE EXPANDER
1 -	LP1 -	LP1 -
1 +	LP1 +	LP1 +
2 -	N/A	LP2 -
2 +	N/A	LP2 +



Proper polarity of the multiplex bus must be maintained.

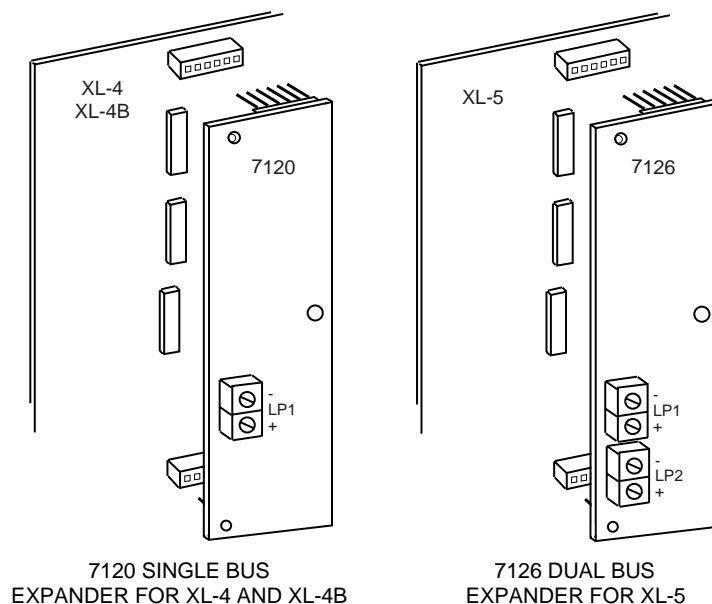

## Keypad Connections

The keypads are connected to the control panel with four-conductor cable to terminals 13 through 16. Attach each keypad used within the system to the terminals as follows:

- T13 Red ( + voltage)
- T14 Green
- T15 Yellow
- T16 Black ( - voltage)

The following rules apply concerning keypad wiring using 22 AWG wire:

- A) Maximum keypad wire runs shall not exceed 1500 feet (any single keypad).
- B) Daisy chain sum of keypad runs shall not exceed 3000 feet. This is the sum of the distances to all keypads from the control panel on one daisy chain branch. For example, if one keypad is 750 feet from the panel and another keypad is 500 feet from the first keypad, then this distance would equal  $750 + (750 + 500) = 2000$  feet. Note that rule A still applies.
- C) Total sum of all single runs and daisy chains shall not exceed 4000 feet. Note that rules A & B still apply. For example, if there were two single keypad wire runs each 1000 feet from the control panel, plus the daisy chain example from rule B, the sum of these wire runs would equal 4000 feet.
- D) If any keypads are powered from sources other than the control panel, then a common ground must be connected between terminal 16 and the ground (negative) of the external power supply.
- E) Keypad wires should be run avoiding sources of possible AC induction or interference caused by other devices. For example, Electrical wiring, Computer wires, etc.

The available keypad power (from terminals 13 and 16) is restricted to 280 mA (250 mA for UL applications). Each keypad draws approximately 70 mA and therefore a maximum of 4 keypads can obtain power from these connections. Additional keypads must obtain their power from the other auxiliary panel outputs (if sufficient capacity is available) or an external power supply.



---

All keypads must be connected to terminals 14 and 15 regardless of where they obtain power.

---

## Keypad Addressing

Both versions of keypads (LED models XK-716 or XK-516 and LCD models XK-7LC or XK-5LC) contain switches to set the address of the keypad. This address will identify the keypad number to the control panel. In a partitioned system each keypad can be assigned to a partition.

Within the control panel programming questions the LED keypads are known as keypads 1-8 and the LCD keypads are known as 9-16.

These switches are located under the cover at the bottom left of XK-516 and XK-5LC keypads. To access the switches in the XK5LC and XK-516 keypads, remove the front of the keypad from the keypad back by placing a straight-slot screwdriver into one of the two slots in the bottom of the keypad and twisting the screwdriver. The switches are located behind the pull open door and zone card for XK-716 and XK-7LC keypads. The switch positions for the keypads are as shown below:

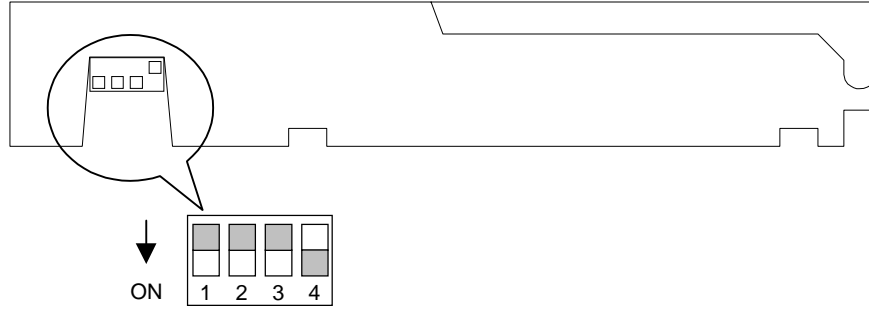

XK-5LC AND XK-516 BOTTOM VIEW (WITH BACK REMOVED)

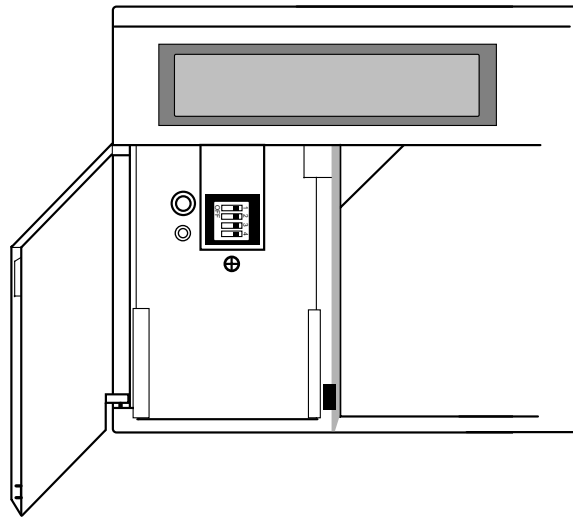

XK-7LC AND XK-716 FRONT VIEW (WITH COVER OPEN)

The first three switches (SW1 - SW3) should be set as follows:

KEYPAD NUMBER		SW1	SW2	SW3
	LCD			
1	9	ON	ON	ON
2	10	OFF	ON	ON
3	11	ON	OFF	ON
4	12	OFF	OFF	ON
5	13	ON	ON	OFF
6	14	OFF	ON	OFF
7	15	ON	OFF	OFF
8	16	OFF	OFF	OFF

On XK-716 and XK-7LC keypads, when the right hand side of the switch is pushed in the switch is in the ON position. When the left-hand side of the switch is pushed in the switch is in the OFF position. On XK-516 and XK-5LC keypads, when the switch is pushed toward the back of the keypad the switch is in the ON position. When the switch is pushed toward the front of the keypad the switch is in the OFF position.

The system should always be powered down and when changing dip switches or hooking up keypads.



The factory default settings enable the first LCD keypad within the system (address 9, SW1-ON, SW2-ON, SW3-ON). At least one LCD keypad is necessary in order to perform keypad programming.



1. Keypads of the same type should not be set with the identical addresses.
2. The keypads need to be enabled within the programming sequence.
3. The control panel supports up to sixteen keypads consisting of eight LED and eight LCD keypads.
4. LED keypads can only be utilized on systems with zone numbers less than 16 zones.

#### Switch 4 - Keypad Sounder

Enables or disables the keypad sounder. In the OFF position the keypad sounder will be active. In the ON position the keypad will only sound indicating the depression of keys.

**UL**

For UL applications the keypad sounder **MUST** be enabled.



This switch is only read upon exit from the keypad programming sequence. Therefore to change the keypad sounder status set the switch (SW4) to the desired position then enter and exit from the keypad programming mode.

### Auxiliary Power

Auxiliary power (13.8VDC regulated) can be obtained from three different outputs of the control panel. The total regulated output power from the control panel is 900 mA (600mA for UL applications) with the following current distribution:

TERMINALS	MAX. CURRENT	APPLICATION
13 (+) & 16(-)	280mA (250mA UL)	Keypads
17 (+) & 16(-) Or 35 (+) & 34 (-)	470mA (250mA UL)	Misc. (Passives etc.).
33 (+) & 32(-)	150mA (100mA UL)	Smoke Detectors

Note: Terminal 35(+) is internally connected to 17 (+). The maximum current available from both of these points added together is 470mA (250mA for UL applications).

Power can be obtained from any of these connections provided that the total does not exceed the rated capacity of the terminals.

Consult the specifications for the devices being connected to determine the power requirements for your installation.

### Programmer Connection

The section of the PC board labeled EZ-MATE Programmer is not used on the control panel. Do not attempt to make any connections.

### JP1

Adding a jumper to JP1 causes earth ground to become the system ground. Alternately, this can be performed by connecting terminal 34 to 18.

**JP2**

Jumper 2 is used in conjunction with the application of relay #1. JP2 should be cut if relay #1 is being used with dry contacts, or left connected if relay #1 is being used as a bell output.

**Default Reset**

Shorting TP1 to TP2 will cause the panel to revert to the original panel default values. This should only be performed if the programming status is unknown and the panel defaults are desired. The control panel default values can be viewed in the LCD Keypad Programming Guide.

To perform a default reset, remove all power to the panel, AC & DC. Short TP1 & TP2 and while short is still intact reapply power AC then DC. Wait 8 to 10 seconds then remove the short while the unit is still powered. The system default reset may take 20 to 30 seconds.



If the INSTALLER LOCKOUT option has been selected within the programming sequence then a default reset through these pins will perform a default with the exception of the CSID and Installer Code.

**Panel Reset**

Shorting connection TP3 to TP2 while the system is powered on will cause a panel reset to occur. This will not alter any of the programming information within the system.

**Local Printer Connection**

This pin (P1) is used to connect to the 7130 Serial Printer Interface Module to output the System Log to a local printer.

NOTE: P1 may be labeled as GND START on the PC board.

**Line Seizure**

This pin (P2) is active (low) when line seizure has occurred.

**Ground**

Connect terminal to a cold water grounding pipe utilizing #16AWG wire at a distance no greater than 15 feet. If the premises pipes terminate in PVC, this terminal must be connected to a 6-foot grounding rod.



To increase lightning and static protection on this panel, we strongly recommend the use of the *Ground Lug* as instructed above instead of using terminal 18. The Ground Lug is located on the lower left-hand corner of the panel.

**Telephone Line**

Connect an FBII model 368 cord to an RJ31X jack as follows:

- 19 Green Telco Tip
- 20 Red Telco Ring
- 21 Brown Home Tip
- 22 Grey Home Ring

The FCC registration number is (AE398E-69554 AL-E) and the ringer equivalent is (0.0B). The control panel should not be connected to party lines or coin operated phone lines. The device should not be connected to a telephone line that has call waiting, unless the call waiting interrupt numbers have been programmed into the panel dialing sequence.



If this control panel will be used for uploading, downloading or remote command applications, the telephone line connected to the control panel must not be shared with a fax machine or modem.

### Tamper Switch

For UL Mercantile installations the circuit board enclosure (panel model XL-4B) **MUST** be tampered. Three mounting holes are provided on the right hand side of the enclosure to install the tamper switch. (AMSECO ATS-1, or ADEMCO No.19) Refer to UL Standard 681 for further information.

### Relay #1

Relay #1 can be used as a bell output or as dry contacts as shown below:

#### Bell Output

UL commercial installations require ADEMCO model AD10-12 or ADEMCO MBL-8 mounted in the model AB bell housing. Maximum alarm load is 1 Amp.

**REFER TO WIRING DIAGRAMS FOR FURTHER DETAILS**

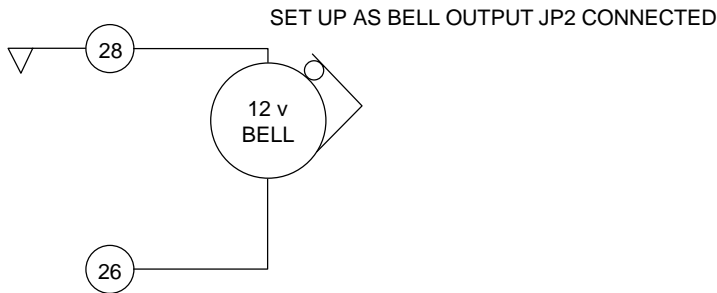

#### Connections To FBII Siren Drivers

Control Panel	679 Siren Driver	VS279 Voice Siren Driver	VS299 Voice Siren Driver
28 (Bell)	1	1	2
30(-)	2	3	7
31 (Const. Power)	N/A	4	6

#### NOTES FOR VS279 & VS299

Burglary message requires Relay 1 programmed for latched operation. Fire message requires relay 1 programmed for pulsed operation.

Consult the Installation Instructions of the siren drivers for additional information.

#### Dry Contacts

Contacts rated 110 VAC, 24 VDC, 3 Amps.

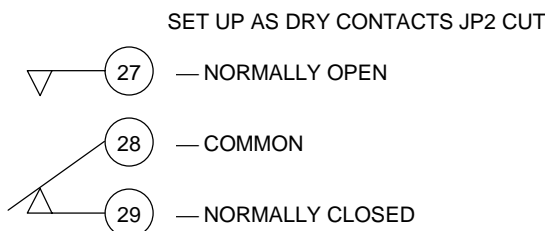

## Relay #2 [Smoke Detector Power Reset]

Relay #2 can be used as a smoke detector reset or as dry contacts as shown below:

### Smoke Detector



To utilize relay #2 as smoke detector power reset connect a jumper between terminals 33 and 24 to power the smoke detectors.

### UL Listed smoke detectors: ESL model 445AT

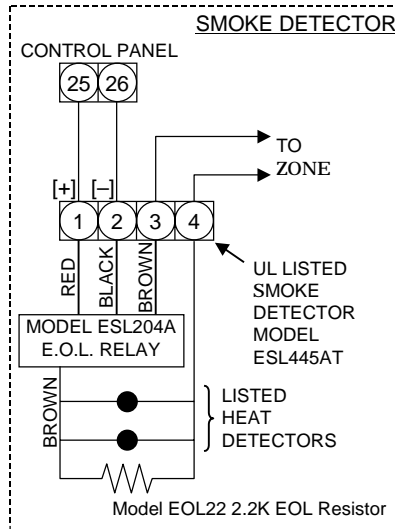

### WARNING

THIS UNIT INCLUDES AN ALARM VERIFICATION FEATURE THAT WILL RESULT IN A DELAY OF THE SYSTEM ALARM SIGNAL FROM THE INDICATED CIRCUITS. THE TOTAL DELAY (CONTROL UNIT PLUS SMOKE DETECTOR) SHALL NOT EXCEED 60 S. NO OTHER INITIATING DEVICES SHALL BE CONNECTED TO THESE CIRCUITS UNLESS APPROVED BY THE LOCAL AUTHORITY HAVING JURISDICTION.

CIRCUIT (ZONE)	CONTROL UNIT DELAY - SEC.	SMOKE DETECTOR MODEL DELAY - SEC*
	20	

\*Obtain from smoke detector installation instructions.

**NOTE:** For installations containing multiple smoke detectors, break the wire to maintain supervision.

**CAUTION:** Incorrect connections may result in damage to the unit.

This hookup applies to the connection of smoke detectors to the hardwired zones of the control panel.



Smoke detector power ranges from 10.2 and 14.0 volts. The maximum voltage available for smoke detectors is 100mA from terminals 32 and 33. Additional power is available through the other aux. power outputs providing that the total power being used does not exceed the rated values of the outputs and that the total power consumed does not exceed the standby requirements. Consult the aux. power section for further information.

The unit has been designed to operate with four wire smoke detectors and end of line relays for supervision of the power to the detectors. Listed below are some recommended smoke detectors and EOL relays:

Gentex Model #6040 & 6041

Voltage 10 - 16 VDC, standby 5mA, Alarm 60mA

ESL Model # 445AT

Voltage 5.1 - 16.5VDC, standby 1.5mA, Alarm 100mA

Power supervision End of Line relay Model 204A

Standby 40mA at 12VDC

BRK System Sensor Model # 2412 or 2412TH

Voltage 11.3 - 17.3, standby 120mA, Alarm 77mA

End of line relay model # A77-716-01

Standby 25mA at 12VDC

**Dry Contacts**

Contacts rated 110 VAC, 24 VDC, 3 Amps.

SET UP AS DRY CONTACTS. NO FIRE ON SYSTEM.

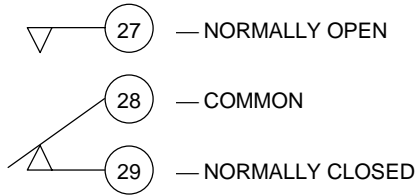

**Trigger Connector**

The control panel contains eight voltage level triggers that are provided through connector P3. The connections for the trigger outputs are displayed below and requires connection of FBII part number 7103UL Trigger Connector. The triggers can be programmed for pulsed or latched operation through the programming questions. The triggers when active deliver 12VDC, 25ma maximum.

Pin 3 of the trigger connector is an Arm/Disarm trigger which can be selected for high or low output through the programming questions and is normally active high (high = 3mA, low = 12mA).

Trigger 7 is the data line and Trigger 8 is the clock line for the XL-4705 relay module, when activated.

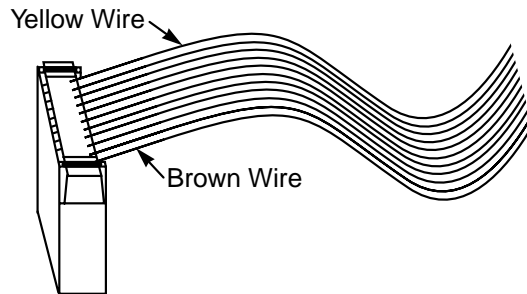

COLOR	CONNECTION
White w/Yellow stripe	Trigger 7
White w/Orange stripe	Trigger 8
White w/Red stripe	Trigger 6
White w/Brown stripe	Arming Status
White w/Black stripe	Trigger 5
Grey	Trigger 4
Blue	Trigger 3
Yellow	Trigger 2
Orange	Ground
Red	Trigger 1
Brown	Ground

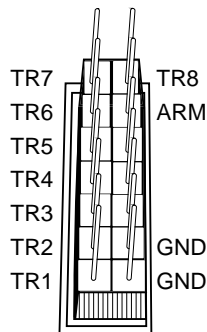

## Transformer

Connect the 16.5VAC 40VA transformer to terminals 36 and 37, using #16AWG wire at 15 feet maximum to an unswitched 120 VAC outlet.



Do not use any other transformer since this may result in improper operation or damage to the unit.

AC loss reporting delay time is programmable in 15-minute increments within the programming sequence. If AC loss is detected then the panel will report the AC loss code using the account number defined for partition #1.

## Battery Backup

The RED (+) and BLACK (-) flying leads must be connected to a 12VDC 5AH GELL CELL, to serve as backup power in the event of AC loss. A 12VDC 5AH GELL CELL battery provides approximately 4 hours of backup. The system performs automatic battery test approximately every 4 minutes, with a low battery level at about 11VDC. If low battery is detected then it will be reported using the programmed low battery code using the account number defined for partition #1. Battery backup requirements for a 24-hour backup will require various backup battery capacities based on the amount of auxiliary power being used by the control panel and auxiliary devices. The chart below summarizes the recommended backup battery requirements based on the auxiliary power being used:

<u>AUX POWER</u>	<u>REQUIRED BACKUP BATTERY</u>
620mA	20AH
300mA	12AH
200mA	10AH
100mA	8AH

To determine the total auxiliary power being used, add the current requirements for all of the external devices connected to the control panel (i.e., smoke detectors, keypads, multiplex peripheral accessories, and zone expander boards). The power does not include the power consumed by the control panel.

## Keypad Mounting

Keypad mounting is identical for both the LED and LCD versions of each keypad. Differences do occur between the XK-7 series (XK-7LC and XK-716) and XK-5 series (XK-5LC and XK-516) Keypads. The XK-7LC and XK-716 Keypads can be surface mounted or flush mounted. Keypad mounting procedures are provided below.



The XK-7LC LCD keypad contains an adjustment located behind the door of the keypad to vary the intensity of the display.

**XK-5LC and XK-516 Surface Mounting**

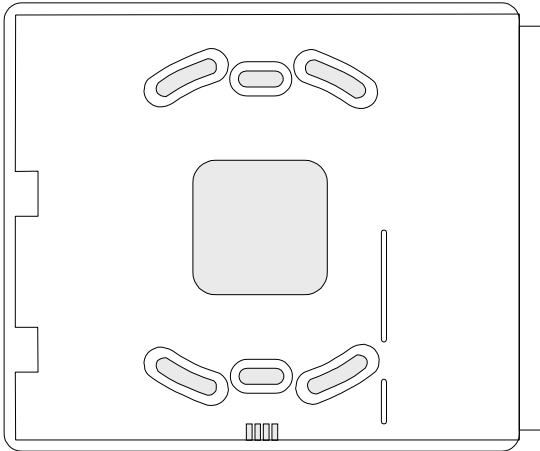

- 1- Remove the front of the keypad from the keypad back by placing a straight-slot screwdriver into one of the two slots in the bottom of the keypad and twisting the screwdriver.
- 2- Select the desired keypad mounting location and place the plastic rear plate of the keypad on the wall. Mark the location of the cutout for the keypad wiring cable.
- 3- Create an opening for the keypad wiring in the location previously marked. Run the keypad wiring using the four-wire connector provided to the control panel.
- 4- Place the keypad wiring through the cutout provided and secure the keypad backplate to the wall through the holes provided (see diagram).
- 5- Connect the keypad wiring connector to the keypad and place the keypad on the mounting plate attached to the wall.
- 6- Snap the keypad front onto the the keypad back.

**XK-7LC and XK-716 Surface Mounting**

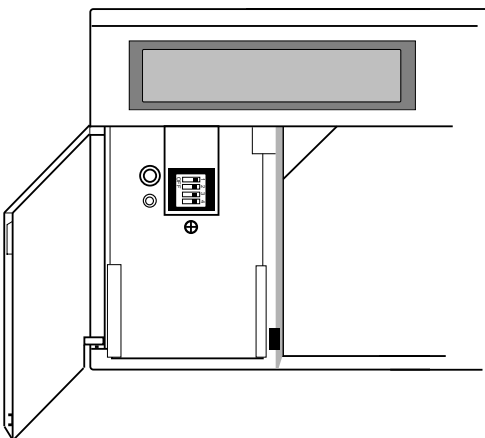
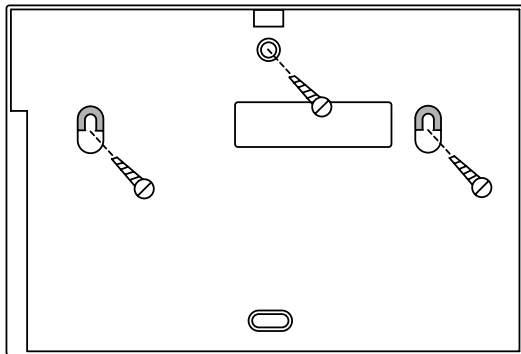

- 1- Select the desired keypad mounting location and place the plastic rear plate of the keypad on the wall. Mark the location of the cutout for the keypad wiring cable.
- 2- Create an opening for the keypad wiring in the location previously marked. Run the keypad wiring using the four-wire connector provided to the control panel.
- 3- Place the keypad wiring through the cutout provided and secure the keypad backplate to the wall through the holes provided (see diagram).
- 4- Connect the keypad wiring connector to the keypad and place the keypad on the mounting plate attached to the wall.
- 5- Secure the keypad to the rear mounting plate by attaching the 5/8-inch screw provided in the lower hole, located behind the keypad door.

**XK-7LC and XK-716 Recessed Mounting**

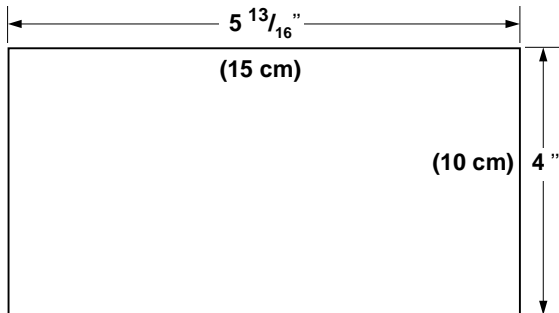

1- Select the desired location for mounting the keypad. Note: For recessed mounting this must be between two studs. Note: The rear plastic mounting plate is not used for recessed installations.

2- Create an opening in the wall exactly 4 inches high by 5 13/16 inches wide. As a template see diagram provided on the inside rear cover of this manual.

3- Turn over the keypad and remove the Phillips head screw (item 1 on diagram) in the upper left hand side of the keypad printed circuit board. Note: This screw is located immediately to the left of the keypad connector.

4- Attach the black metal mounting strap to the rear of the keypad as follows (see diagram):

- Face the pointed section of the mounting strap facing the front of the keypad. This will be used to latch onto the inside of the wall.

- Place the small white plastic spacer underneath the mounting strap. Secure the mounting strap using the 5/8 inch Phillips head screw (supplied with the keypad mounting hardware) and the plastic spacer to location 1.

- Secure the other end of the strap (location 2 on diagram) to the white plastic opening using the Phillips head screw removed in step 2.

5- Connect the white plastic tab into the round opening immediately behind the keypad door. Place the longer Phillips head screw located with the keypad mounting hardware through the opening inside the keypad door and begin to tighten the screw. At this point, loosely tighten the screw and leave the tab in a downright position.

6- Run the keypad wiring to the control panel and attach the wiring to the keypad.

7- Place the keypad into the wall opening with the side containing the black metal strap first. The black metal strap with the hook will act as a spring and grab the inside of the wall.

8- After inserting the side of the keypad with the metal strap, insert the other side into the opening until the entire keypad is firmly in the wall. Straighten out the keypad to the desired position.

9- Open the keypad door and completely tighten the screw inserted in step 5. This will cause the plastic piece previously inserted into the back to flip up and tightly grab the inside of the wall.

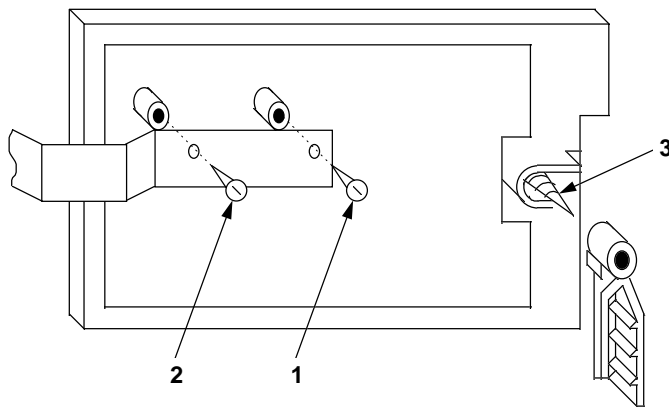



# Multiplex Polling Loop

## In This Section

- ◆ *Multiplex Expander Installation*
- ◆ *Polling Loop Overview*

Expansion of the system can be accomplished through addition of the 7120 (XL-4) or 7126 (XL-5) Multiplex Loop Expander module to the expansion slot of the control panel. The 7120 board provides an additional 64 zones through a two-wire multiplex polling loop. The 7126 board provides an additional 120 zones through a two-wire multiplex polling loop. Each of the points connected to the bus will be known as separate system zones as follows:

Zones 1-8	Hardwired zones located on circuit board
Zones 9 – 72 (XL-4)	Multiplex zones through the 7120 module [multiplex bus]
Zones 9 – 128 (XL-5)	Multiplex zones through the 7126 module [multiplex bus]



The multiplex loop can accommodate 64 (7120) or 120 (7126) points, with any combination of point types.

## Multiplex Expander Installation

The 7120 or 7126 Multiplex expander module provides a two wire multiplex bus to the control panel. The 7120 or 7126 Multiplex expander can be installed as follows:

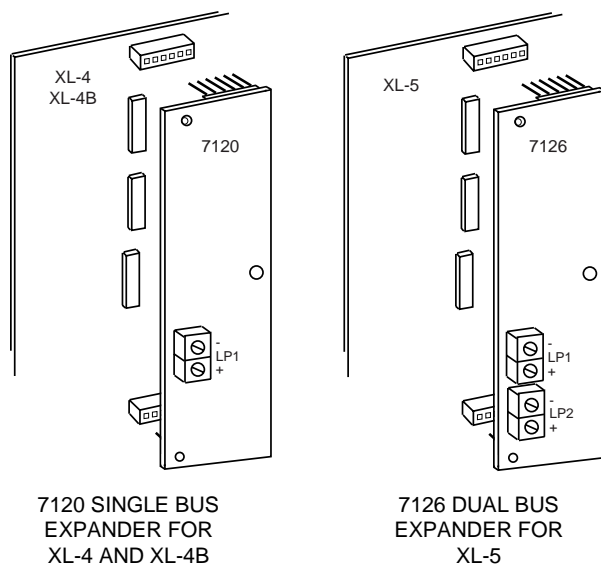

- 1- Remove all power from the control panel.
- 2- Attach the three plastic support mounting pieces to the multiplex expander module in the three holes located on the printed circuit board of the multiplex expander. Place the pointed end through the bottom of the multiplex expander.
- 3- Attach the multiplex expander to the control panel through the plug in connections located to the left of the heat sink. Carefully align the six pins on the top and bottom of the mounting connectors. Press down firmly on the expander board to insure that the board is secure in both connectors.

**Note:** In order for the control panel recognize the multiplex expander the programming option enabling multiplex operation must be turned on. This can be performed through the keypad programming sequence or through the EZ-Mate PC Downloading software. Consult the appropriate manuals to determine the method to enable the multiplex capability.

The multiplex busses can be connected as follows:

MULTIPLEX BUS LOOP NUMBER/POLARITY	7120 MULTIPLEX ZONE EXPANDER	7126 MULTIPLEX ZONE EXPANDER
1 -	LP1 -	LP1 -
1 +	LP1 +	LP1 +
2 -	N/A	LP2 -
2 +	N/A	LP2 +



Proper polarity of the multiplex bus must be maintained.

Maximum current output of the multiplex polling loop (LP1) is **75mA**. The 7126 has an additional output (LP2) which also has a maximum current output of **75mA** providing a total current output of **150mA**. Consult the polling loop accessory worksheet to determine the proper operation of polling loops. If the power is exceeded on the multiplex bus or the distance for the gauge of wire used is exceeded, then the multiplex extender module can be utilized to provide additional power to the multiplex bus.

### Polling Loop Overview

The multiplex polling loop consists of a two-wire bus between the control panel and the multiplex peripherals. The polling loop provides power to the multiplex accessories and serves as a communications path between the control panel and the individual sensors.

Each sensor must be assigned a unique address that will correspond to the zone number within the control panel. Consult the installation instructions for the individual multiplex accessories to determine address selection. On most of the devices, a series of dip switches will select the address (or zone number) for that device.

The 7120 multiplex bus can accommodate 64 points and the 7126 multiplex bus can accommodate 120 points as follows:

- The 7120 multiplex bus can contain no more than 64 points and the 7126 multiplex bus can contain no more than 120 points. The number of points depends on the type of multiplex accessory used. For example, if the 8 zone multiplex adapter is used then this device counts as 8 points.
- Duplication of point (zone) numbers within the multiplex loop is not permitted
- Total power requirements for the multiplex devices connected to the bus must not exceed 75mA (150 mA for the 7126, see polling loop worksheet). If the power requirements exceed the capacity of the bus then the multiplex loop extender can be used to provide additional power to the bus.

### System Powerup

Upon initial system powerup or system reset (exiting from programming mode), the control panel will determine the valid multiplex points based on the multiplex expander option which is defined within the programming sequence. These options are described below:

*Multiplex Expander 1* will automatically scan the multiplex bus and determine the active multiplex points based on the points physically connected to the multiplex bus at the time of powerup. In this mode each multiplex point must be programmed to the desired attributes, and be connected and operational to the multiplex loop at the time of system reset.

*Multiplex Expander 2* determines the valid zones based on the programmed zone attributes. Valid zones are defined as any multiplex zone (9 - 72) that contains a zone attribute that can generate an alarm or trouble condition on open or short. Inactive points will be zones that have the alarm/trouble on open or short questions all answered as NO. If zones are missing that have been defined within the programming sequence then these zones will appear in the

system log and the keypad will display “SYSTEM NOT READY Zn #”, “CHK LOG & RESET! MPX ZONE ERRORS”, or “SYSTEM NOT READY SUPERVIS ZN #”. If extra zones exist that have not been defined in programming, then the keypad will display “CHK LOG & RESET”, “MPX ZONES ERRORS” and the event log will reflect “Extra Zone Zn#”. All zones must be enabled in programming even if not used.



Whenever additional points are added to the multiplex bus it is necessary to define the zones to the desired attributes within the programming sequence.

### Zone Definition

The multiplex points must be defined within the programming sequence to contain the desired attributes. Consult the LCD Keypad Programming Guide or the EZ-Mate PC Downloader for more details.

### Configurations

Any of the multiplex point accessory devices can be used, in any combination, to obtain up to 64 points on the multiplex bus. The polling loop can be run in a variety of configurations as shown in the diagrams below. The configuration should be selected to suit the particulars of each installation, however the polarity of the system must be maintained throughout the loop. If the polarity of the loop is reversed at any point an alarm conditions will be generated.

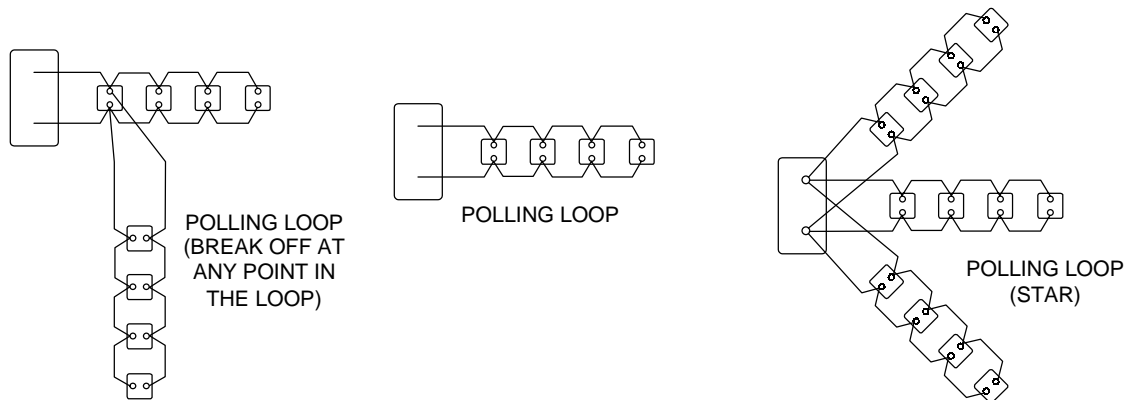

The individual multiplex points must be wired in parallel to the two-wire polling loop, making sure that no more than the maximum allowable wire length is used per loop run as follows:

	<u>NON-SHIELDED</u>	<u>SHIELDED</u>
#22 gauge	@650' maximum	@325' maximum
#20 gauge	@950' maximum	@475' maximum
#18 gauge	@1500' maximum	@750' maximum
#16 gauge	@2400' maximum	@1200' maximum



Twisted pair is recommended for all normal wire runs.

**IMPORTANT:** The maximum combined polling loop run is 4000'. If using shielded wire, the maximum is 2000'. If longer runs are needed, the Multiplex loop Extender Module must be used.

**Intercom Considerations**

If an intercom system is used, the multiplex polling loop wires must be as far from the intercom wiring as possible (minimum 6"). If this spacing cannot be achieved, shielded wire must be used. If this is not done, interference on the intercom system might occur. Also note that the maximum total wire length supported is cut in half when shielded wire is used.

**Supervision**

The control panel will poll points that exist on the polling loop. If the point is not found, a supervision error exists. This could occur if a point has not responded or if a portion (or all) of the polling loop has been removed. Supervision problems will be handled based on the programming characteristics of the specific point and the arming status of the panel. For example if the point is defined as a 24-hour alarm, an alarm condition will be generated based on the programming of that zone. If the zone is a non-24 hour zone then an alarm will be generated only if the system is armed.

**Tamper**

The two point multiplex adapter modules contain a built in tamper switch. If the cover on the individual module is removed then an alarm condition will be generated based on the programming characteristics of the left loop of that device. For example, if the left loop is defined as a 24-hour device then an alarm condition will be generated; if a non 24-hour alarm (controlled device) then the reaction will depend on the arming status.

**Power Considerations**

The maximum allowable current draw for the polling loop is 75mA (75mA per loop output on the 7126). In order to confirm that you are not exceeding the current limitations of each multiplex bus, complete the following worksheet based on the types of devices connected to each bus:

MULTIPLEX LOOP POWER WORKSHEET

Multiplex Device	Maximum Current	Mux Loop			
		LP1		LP2 (7126 ONLY)	
		# Devices	Current	# Devices	Current
2 Point * [XL-4702] Multiplex Adapter	1mA Low Setting 2mA High Setting				
8 Point * [XL-4708] Multiplex Adapter	16mA				

\* Burglary Applications Only TOTAL

NOTE: Maximum current of 75mA for LP1 and 75mA for LP2

The following listing provides the current requirements for the multiplex peripheral devices:

<u>MODEL</u>	<u>NAME</u>	<u>CURRENT</u>
XL-4701	Single Point Multiplex Interface	1mA
XL-4702	2 Point Multiplex Adapter Module	1mA
XL-4708	8 Point Multiplex Adapter Module	1mA
XL-4722	Dual Element Passive	1mA
XL-4750SDT	Smoke Detector	1mA
ZR-745MSL	Recessed Contact with RPM	1mA
ZR-750MOH	Multiplex Overhead Door Contact	1mA
ZR-795MR	Recessed Multiplex Contact	1mA

# System Operations

## In This Section

- ◆ Keypad Layout
- ◆ Sample LCD Display
- ◆ Arming The System
- ◆ Stay
- ◆ Instant-Stay
- ◆ Bypass
- ◆ Forced Arming
- ◆ Unbypass
- ◆ Groups
- ◆ Group Bypass
- ◆ Group Unbypass
- ◆ User Programming
- ◆ User Deletion
- ◆ Disarming
- ◆ Keypad Auxiliary Conditions
- ◆ Duress/Ambush
- ◆ LCD Keypad Programming Mode
- ◆ Quick Commands
- ◆ Log Dump Function
- ◆ Keypad Function Summary

The purpose of this section of the manual is to describe how to perform routine functions on the control panel.

## Keypad Layout

The system can be operated through either the LCD keypad (models XK-7LC or XK-5LC) , or the LED keypad models XK-716 or XK-516. As many as eight of each keypad type can be connected to each control panel.



The LED based keypad (models XK-716 or XK-516) shall only be utilized on systems containing zone numbers less than sixteen. These keypads can only indicate the status of the first sixteen zones.

The keypads have the following appearance:

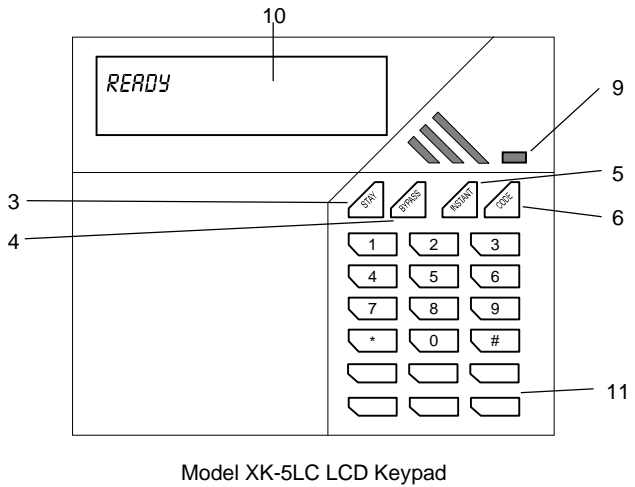
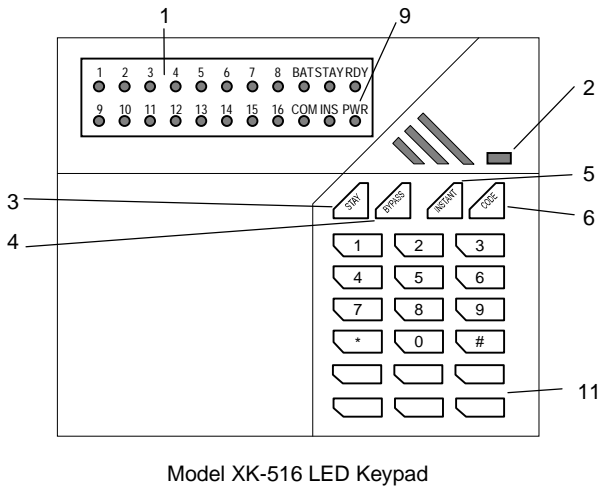
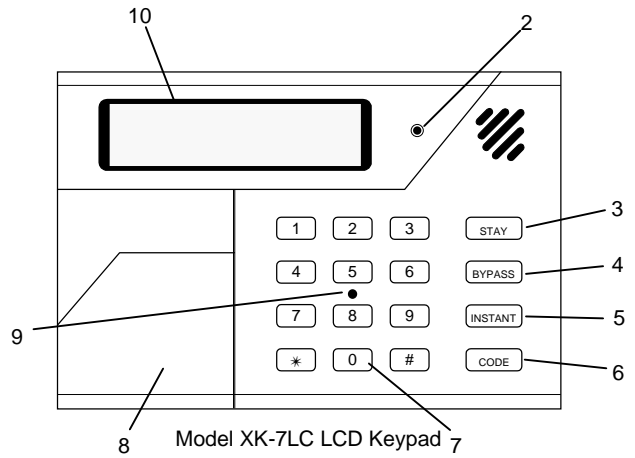
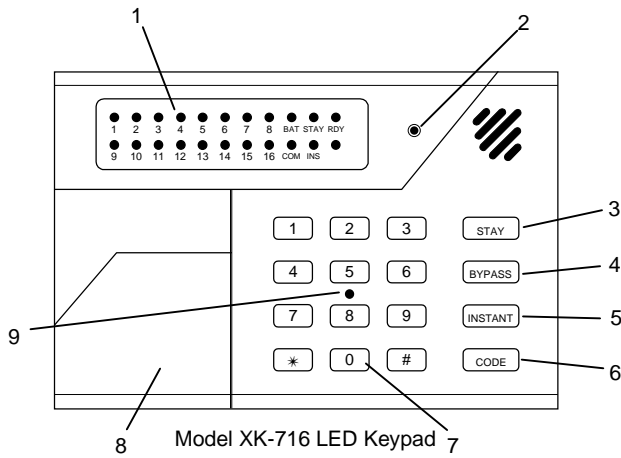

**1) LED KEYPAD INDICATOR LIGHTS**

This section of the LED keypad displays the current system status using indicator lights for the various zones and system conditions.

The zone indicator lights work as follows:

**ALARMS** Fast Blink (approx. 150 msec. ON - 150 msec. OFF). As alarms are being displayed, the other indications (bypass, trouble and faulted zone) are suppressed.

**TROUBLES** Slow Pulse (approx. 600 msec. ON - 600 msec. OFF). As troubles are being displayed, all bypass and faulted zone indications are suppressed.

**BYPASSES** Slow Blink (600 msec. ON - 600 msec. OFF). Zone bypasses are displayed as a very slow blink of the zone indicator light.

**FAULTED ZONES** Solid ON. Faulted zones are displayed with the LED solidly ON.

The remaining LEDs display current system status as follows:

**BAT** - Indicates low battery condition ON = Low Battery, OFF = Normal.

**STAY** - LED ON when the system is armed in the STAY mode. Slow Blink (600 msec. ON - 600 msec. OFF) when the system is armed in the AUTO STAY mode.

**RDY** - LED ON when the system (or partition) is Ready to be armed. The LED will go OFF if any of the zones are not READY.

**COM** - Indicates a communications failure with the Central Station. This will be active if the panel has attempted unsuccessfully for the maximum number of attempts with the CS. If the communication failure LED is on then entry of a valid user code is required to turn the LED off.

**INS** - Indicates whether the system has been armed in the instant mode.

## **2) ARM/DISARM INDICATOR**

This LED indicates whether the system is currently armed (activated) or disarmed (deactivated). If the system partitioned then this indicator reflects the arming status of the partition assigned to the keypad.

## **3) STAY**

The STAY mode ARMS the system with the exception of interior protection. This will provide perimeter protection of the location while allowing access through the interior of premise.

## **4) BYPASS**

The BYPASS key is used to temporarily turn off protection to a portion of the premise. Zones can be bypassed by authorized users for zones that have been defined as bypassable.

## **5) INSTANT**

The INSTANT mode arms the system and eliminates the entry delay.

## **6) CODE**

Function key used to perform various system functions through the keypad including Programming, Walk Test, User Code Modification, and System Activity Log View.

## **7) NUMERICAL KEYPAD**

The numerical section of the keypad operates in a similar manner to a calculator or TouchTone telephone. The digits 0 - 9 are clearly marked and used to enter numerical values. In addition to the numerical keys there are \* and # keys which are used to perform certain functions that require multiple keystrokes.

## **8) PULL OPEN DOOR**

The front of the keypad contains a door that pulls open. Behind this door is a zone description card and end user instructions.

In addition, on the LCD keypads there is an intensity adjustment inside the door of the keypad. This adjustment can be made to optimize the LCD intensity to suit the installation.

## **9) POWER INDICATOR**

The indicator light located shows that AC power is connected to the system.

## **10) LCD DISPLAY AREA**

The display area of the LCD keypad contains a two line by sixteen-character read-out that continuously shows the current system status. The information displayed will be custom tailored for each installation based on the programming values. For example, if a zone has been violated the display will contain the zone number and a description of the zone location. The display area is backlit providing readability in a variety of lighting conditions. The LCD keypad can also be used for programming and the display area will contain the programming questions.

**11) EMERGENCY KEYS**

These keys generate Fire, Medical, or Panic signals when certain key combinations are entered.

**Sample LCD Display**

The LCD keypad consists of a two line by sixteen-character display as shown in the sample below:



This sample display indicates that a burglary has taken place in zone 055, which corresponds in the example shown above to the master bedroom.

**Keypad Function Keys**

Throughout this section of the manual the following conventions will be used to describe the keystroke actions performed from the keypads.

BYPASS	Function key labeled BYPASS
INSTANT	Function key labeled INSTANT
STAY	Function key labeled STAY
CODE	Function key labeled CODE
*	Key labeled * within numerical section of keypad.
#	Key labeled # within numerical section of keypad.
[USER]	Four digit user code. These codes must already be programmed into the system and represent the valid users of the panel. User codes can be entered into the system through an external programming device, through an installer keypad programming session, or by an authorized user through the keypad. Note: From an initial default state the panel will contain the user code 1234. Either the installer or end user must program all other user codes. Note: An option exists within the programming sequence to select a 7-digit user code. If a seven digit user code is selected then the user code will be the three digit user number followed by the four digit user code (example user number 43 with a user code of 7543 will be 0437543)
+	Indicates the simultaneous entry of two keys. For example, * + 3 means that the * and 3 keys should be pressed at the same time.
[Installer Code]	Six-digit code required to gain access to the installer mode functions. This value can be modified through keypad programming or the external programming devices. The default value for the installer code is 123456.

**Arming The System**

System arming can be performed only if the system is ready.

**System Ready**

Under normal disarmed conditions the following message will appear in the display area of the LCD keypad:

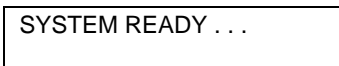

Note: The second line can contain a partition description that describes the location of the alarm system (example, SMITH RESIDENCE). In addition the second line can scroll through

additional system information such as zone bypasses. This message indicates that all the zones are READY and that there are currently no conditions that could prevent arming. On the LED keypad the system is ready if the RDY LED is ON.

### Arming Procedure

#### [USER]

Enter the four-digit user code. In order to arm the system the user must be defined as a valid user within the partition. The system has been successfully armed when the following display appears on the LCD keypad only:

```
ON: AWAY . . . . .
. . . Exit now . . .
```

The ARMED indicator will now be lit and the user may exit through an exit/entry zone for the time period established as the exit delay. The EXIT NOW message on the second line of the display will appear for the duration of the exit delay (LCD keypads only).

### System Not Ready

If the system is not ready to be armed the LCD keypad display will scroll through the zones that are currently not ready. For example;

```
NOT RDY: Zne 005
MASTER BEDROOM
```

```
SYSTEM NOT READY
```

This display indicates that zone number 13 is not ready. The display contains three digits to display the zone number. When the problem with zone 13 has been corrected the READY display will appear. Note: If more than one zone is not ready then the zones that are not ready will scroll on the display approximately every two seconds.

On LED keypads, the RDY LED will be off when the system is not ready, and the zone(s) LEDs that are not ready will be ON.

The system can not be armed if there are zones in TROUBLE condition. For example:

```
TROUBLE ZN 003
REAR FOIL
```

In order to clear a trouble display a valid user code must be entered. When the trouble has been cleared the SYSTEM READY indication should reappear. Alternately, the reset function (depression of the \* key based on programming option) can be performed to clear troubles if the reset option has been enabled within the programming sequence.

In order to arm the system when not ready one of the following actions are necessary:

- Make the zone(s) ready. Determine which zones are not ready and perform the action necessary to ready the zone(s) (example, close the door or window, etc.)
- or
- Bypass the zones(s) that are not ready. Bypassing should only be performed if the zone cannot be made ready or intentionally will remain not ready.
- or
- Force arm the system, bypassing all zones which are not ready.



The system can be armed without the back-up battery connected.

## STAY

The STAY mode will ARM the system and deactivate any interior protection zones that exist within the system. In order to perform the STAY function the system must be ready. See description of READY state within ARMING sequence.

### Stay Procedure

#### STAY [USER]

Depress the STAY key followed by any valid four-digit user code.

Following a successful STAY arming the following display will appear on LCD keypads:

```
ON: STAY . . . . .
. . . Exit now . . .
```

The EXIT NOW message will appear on the second line of the display for the duration of the exit delay. In addition the ARMED indicator will be lit. The second line of the display may scroll through zones that have been bypassed.

On LED keypads both the ARMED and STAY indicators will be lit.



An option exists within the programming sequence to determine whether bypasses are transmitted to the CS when performing STAY arming.

## Auto Stay

The Auto Stay mode will ARM the system bypassing selected zones which have been defined as Auto Stay zones. Auto Stay zones are burglary zones with Bypass and Auto Stay enabled. Auto Stay is enabled in the same manner as AWAY except, the entry/exit door must not be opened during the exit delay period.

### Auto Stay Procedure

#### [USER]

Enter any valid four-digit user code. In order to arm the system the user must be defined as a valid user within the partition. Following a successful entry, the following display will appear on LCD keypads:

```
ON: AWAY . . . . .
. . . Exit now . . .
```

The ARMED indicator will now be lit. The message on the display will appear for the duration of the exit delay. DO NOT PASS THROUGH AN ENTRY/EXIT ZONE DURING THE EXIT DELAY. At the end of the exit delay, the following display will appear on LCD keypads:

```
ON: AUTO STAY
```

## INSTANT

The INSTANT mode ARMS the system and eliminates the entry and exit delay time period. This mode should be used when the violation of any protected zone should cause an instant alarm.

The system must be READY to perform the INSTANT function.

### Instant Procedure

#### INSTANT [USER]

Upon successful INSTANT arming of the system the ARMED indicator will be lit and the following display appears on LCD keypads:

ON: AWAY INSTANT

On LED keypads both the ARMED and INSTANT LEDs will be lit.

The INSTANT option will automatically be reset after the system is disarmed. The second line of this display can scroll between various system conditions such as zones that are currently bypassed.

## Instant-Stay

The INSTANT-STAY mode will arm the system with the characteristics of both the INSTANT and STAY modes. The system will be armed with the interior portions bypassed and the entry and exit delays will be suspended.

The system must be READY in order to perform this function.

### Instant-Stay Procedure

**INSTANT STAY [USER]**

or

**STAY INSTANT [USER]**

After a successful INSTANT STAY arming the armed indicator will be lit and the following display will appear on LCD displays:

ON: STAY INSTANT

On LED keypads the ARMED, STAY and Instant LEDs will be lit.

## Bypass

Bypasses are performed to exclude burglary zones that are faulty or not ready from activating the system. In order to bypass a zone, the zone definition must specify that the zone can be bypassed. In addition, the user performing the bypass must be authorized for bypass (levels 1, 2, 3 or 4).

Bypassing is only permitted if there are no alarms or latched troubles present in the system. In addition, a zone cannot be unbypassed if its current state would put the zone into an alarm state.

### Bypass Procedure

**BYPASS [USER] ZN**

where:

ZN Three digit zone number.

For example to bypass zone 17 enter;

BYPASS [USER] 017

Multiple zones may be bypassed by repeating the sequence for the desired zones within a fifteen-second interval as shown in the following example:

BYPASS [USER] 002 BYPASS 043 BYPASS 055 Bypass zones 2, 43, and 55

If a zone entered is already bypassed, the sequence will unbypass the zone except if the system is armed and the bypassed zone is still not ready.

After a bypass or unbypass command has been accepted the LCD keypad will emit a continuous beep and display;

BYPASSED Zne 002  
UPSTAIRS BEDROOM

or

UNBYPASS Zne 002  
UPSTAIRS BEDROOM

Note: Bypassing can be performed either while the system is armed or disarmed.

A bypass signal will be transmitted to the Central Station if a bypass code has been programmed and the zone has been enabled for bypass. If the system is disarmed an option (auto unbyypass enable) exists to retain the bypassed zones until a manual unbyypass is performed.

To immediately ARM the system enter [USER] after the last zone bypass.

On LED keypads the zone indicator LED for that zone will blink slowly.



If a zone is already bypassed, the bypass command will unbyypass the zone. Bypassed zones will not be protected when the system is armed.

### Forced Arming

Forced Arming is a method that will automatically bypass all faulted zones and ARM the system.

#### Forced Arming Procedure

##### **BYPASS [USER] BYPASS**

If any of the zones currently faulted are not bypassable, then the command will not succeed, and a long beep will follow. A programming option exists to determine whether forced arming is permitted.

Following a successful FORCED ARMING the ARMED indicator will be lit and the ARMING (ON:AWAY) message will appear on the LCD display. Note: Forced arming capability can be enabled or disabled through the programming sequence. User must be a level 1,2,3 or 4.



If the auto unbyypass option is enabled and an alarm occurs during the armed period upon disarm, bypassed zones will be retained until a second reset is performed.

### UL

For UL applications this feature MUST not be enabled.

### Unbypass

The UNBYPASS function removes an existing bypass from a currently bypassed zone. The procedure is similar to a bypass.

#### Unbypass Procedure

##### **BYPASS [USER] ZN**

See bypass description.

### UL

For UL systems bypassed zones should automatically be unbyypassed during disarm (see auto-unbyypass option in programming guide).

## Groups

The system contains a concept known as groups. This allows multiple zones within a partition to be grouped together for bypassing and alarm transmission purposes. There can be up to 24 groups.

### *HOW TO DEFINE A GROUP*

A programming option has been added to the zone definition section to define whether the zone should be considered as [part of a group. If enabled, then the group number will be the determined by the alarm type or trouble type if there is no condition for that zone which can activate an alarm. The group will contain all of the zones (within the partition) of the same alarm type or trouble type that has been programmed as part of a group. The group number will be the alarm type (01 - 16) or trouble type (17 - 24) for that zone. Therefore, to create a group within a partition, the following items must be programmed:

- Group enable question for the zone must be answered as YES
- Zones desired for the same group must all specify the same alarm or trouble type
- Zones must be within the same partition

Groups affect the traffic transmitted to the Central station for alarms and restores. Alarms will only be transmitted to the CS for the first zone within the group that goes into alarm. Subsequent alarm conditions from other zones within the same group will not transmit to the CS. Local indications such as keypad display, keypad sounder and bell output will remain the same. In addition, all activity will enter the system log.

Restores for groups will only be transmitted after all of the zones within the group have restored. In addition the restore code will be transmitted for the first zone number in the group that went into alarm.

## Group Bypass

Entire groups can be bypassed using the following procedure:

### **Group Bypass Procedure**

#### **BYPASS [USER] \* 1 GP**

Where:

BYPASS = Bypass Key on keypad

[USER] = User Code

\* 1 = \* 1 keys

GP = Group number (01 - 24). The group number will be the alarm type (01 - 16) or the trouble type (17 - 24, for trouble types 1 - 8 example trouble type 1 = group 17)

This procedure will bypass all of the zones within the partition defined as part of the group.

For example to bypass group 3 enter:

BYPASS [USER] \* 1 03

If the quick bypass (# 5 command) has been enabled, then the following keystrokes can be used:

QUICK GROUP BYPASS        # 5 \* 1 xx (Where XX is the group number)

QUICK GROUP UNBYPASS    # 5 \* 2 xx (Where XX is the group number)

## Group Unbypass

Groups can also be unbypassed through the following command:

### Group Unbypass Procedure

**BYPASS [USER] \* 2 GP**

where:

BYPASS = Bypass Key on keypad

[USER] = User Code

\* 1 = \* 1 keys

GP = Group number (01 - 24). The group number will be the alarm type (01 - 16) or the trouble type (17 - 24, for trouble types 1 - 8)

This procedure will remove the bypasses from all of the zones within the partition defined as part of the group.

For example to remove the bypasses from all zones within group 3 enter:

BYPASS [USER] \* 2 03

If the quick bypass (# 5 command) has been enabled, then the following keystrokes can be used:

QUICK GROUP UNBYPASS # 5 \* 2 xx (Where XX is the group number)

## User Programming

Users can be programmed through the keypad in addition to the external programming devices. Keypad programming allows authorized users to change user access codes and authorization levels.

Note: The initial user authorization levels and partition assignments are initially setup through the EZ-Mate PC Downloader, LCD Keypad programming, or obtained through the default values.

Users within the control panel have the following characteristics:

USER NUMBER	The XL-4 system accommodates up to 64 (XL-4) or 128 (XL-5) different user codes. The user number determines which user is being defined or modified with numbers ranging from 001 – 064 (XL-4) or 000 – 128 (XL-5).
USER ID	Actual four digit code (0000 - 9999) entered at the keypad to perform the keypad operations described in this section. This value is displayed throughout this chapter as [USER]. USER ID's cannot be duplicated within the same panel.
AUTHORIZATION LEVEL	Each user of the system is assigned an authorization level which determines access to various system functions as described below: LEVEL 1 - ARM, DISARM, BYPASS, PROGRAM USERS, CHANGE PARTITION ASSIGNMENTS IN ALL PARTITIONS LEVEL 2 - ARM, DISARM, BYPASS, PROGRAM USERS, CHANGE PARTITION ASSIGNMENTS IN OWN PARTITION LEVEL 3 - ARM, DISARM, BYPASS, PROGRAM USERS LEVEL 4 - ARM, DISARM, BYPASS LEVEL 5 - ARM, DISARM LEVEL 6 - DURESS CODE LEVEL 7 - ARM ONLY (Maid Code)



Multiple users can be assigned the same authorization level and perform the identical functions.

### User Programming Procedure

#### CODE [USER]

Depress the CODE key followed by the four-digit user access code. The user code entered must be a level 1, 2, or 3 user. Assuming that the user is authorized to perform programming within the specified partition the following displays will appear:

(XL-4)

```
ENTER User No. . .
001-064, *= exit
```

(XL-5)

```
ENTER User No. . .
001-128, *= exit
```

Enter the user number to be entered or modified. The user number must be entered as a three-digit value; for example user #3 will be entered as 003.

```
ENTER User CODE
* exit, # erase
```

Enter the four-digit user code to be defined. The user code entered (0001 - 9999) must be unique and cannot be a duplicate of another existing user code. If an invalid code is entered, the keypad will beep four times and the keypad will repeat the question.

The last question within user definition is the authorization level. Note: Users cannot program authorization codes higher than their own level. Enter the desired value from 1 to 7 as follows:

```
ENTER Authority
1 - 7, * to exit
```

After completion of the user code either enter another user code or press \* to exit.

Example: Define user #3 with an ID of 7493 with an authorization level of 2. [Assume a level 1 user code of 1234]

```
CODE 1234 003 7943 2 *
```

### User Deletion

Removal of users from the panel can be performed as follows:

#### User Deletion Procedure

**CODE [USER] [User #] #**

where:

[User #] Represents the user number being deleted (001 – 064 for the XL-4 or 001 – 128 for the XL-5).

User deletion can only be performed by a level 1, 2, or 3 user code.

Example: Delete user number 4 (Assume a level 1 user with a code of 2468).

```
CODE 2468 004 #
```

The deletion procedure should be used only when the user being removed is not being replaced with another user.

## Disarming

To disarm the system from an armed state:

### Disarming Procedure:

#### [USER]

Enter a valid user code.

The keypad display that appears on LCD keypads depends whether or not alarms have taken place while the system was armed.

#### A) IF NO ALARMS HAVE TAKEN PLACE

The system disarming will optionally remove all bypasses and the ARMING indicator will go off. The system display will reflect the current status.

#### B) IF ALARMS HAVE TAKEN PLACE

If alarms or other conditions have taken place since the initial system arming, they will appear on the display. The alarm(s) that have occurred will scroll on LCD keypads approximately every two seconds in time sequence as shown in the sample displays below;

BURGLARY	zn012
MASTER BEDROOM	

BURGLARY	zn055
LIVING ROOM	

FIRE	zn004
MAIN HALLWAY	

After scrolling through the alarms, the display will return to the first condition and repeat the sequence of alarms until the system is cleared.

On LED keypads the zones that were in alarm will pulse rapidly. To acknowledge the conditions and clear the display of the alarm signals enter [USER] again, or the \* key if the RESET function has been enabled.

## Keypad Auxiliary Conditions

In addition to individual zone alarms the control panel contains three programmable keypad aux. conditions. These conditions are initiated through the depression of two keys as listed below:



The keypad auxiliary conditions are active 24 hours a day.

The three keypad conditions can be initiated as follows:

CONDITION	KEYSTROKES (ALL KEYPADS)	ADDITIONAL COMBINATIONS USING XK-516 or XK-5LC KEYPAD EMERGENCY KEYS
FIRE	3 + # or 7 + 9	Left 2 Keys
MEDICAL	1 + *, 1 + 3, or 4 + 6	Middle 2 Keys
PANIC	* + #	Right 2 Keys

Note: + indicates the simultaneous depression of the two keys shown. For example, 3 + # indicates pressing the 3 and # keys at the same time.

## Duress/Ambush

The system contains duress capability, which can be obtained through use of a user code with an authorization level of 6. The duress feature will report to the Central Station based on the parameters defined as keypad condition number 4.

## LCD Keypad Programming Mode

Installer programming can be performed through a LCD keypad to view or modify the programmable characteristics of the control panel. Entry into this mode will obtain numbered displays corresponding to the programming questions. Within the programming mode the installer can scroll through the questions sequentially or directly access any question. Full details on keypad programming can be found in the LCD Keypad Programming Guide.

## Quick Commands

The system contains some quick command functions that can be enabled or disabled through the programming sequence. These commands can be initiated by the end user through depression of the # key followed by the command number (and CODE key for Multi-Partition Mode) as shown below;

<u>SEQUENCE</u>	<u>COMMAND</u>
# 0 CODE	Keypad Common Partition Display
# 1	Quick Arming
# 2	Quick Forced Arm
# 3	Time/Date Set and Auto Arming*
# 4	LCD Zone Directory *
# 5	Quick Bypass
# 6	Chime On/Off
# 7	User Partition Assignment *

\* LCD Keypads Only



Each of the quick arming commands can be enabled or disabled through programming options.

### Keypad Common Partition Display [# 0 CODE]

The control panel can be configured to appear as multiple separate security systems. Each subgroup is known as a partition and users can be valid in different partitions. Each partition would contain its own zones and keypads and would normally be operated independently.

The keypad common partition display allows authorized users to view the status of all partitions and to perform functions to their assigned partition from any keypad within the entire system. The user will only be able to perform the functions authorized for that user. To enter the keypad common partition display, enter # 0 followed by a valid user code. LCD keypads will display:

ENTER PART (0 - 9) # VIEW, * EXIT
--------------------------------------

Next enter the desired partition. Note: The user must be authorized within the requested partition. Entry of 1 - 8 will return with the keypad displaying the status of the requested partition. At this point the user can perform any of the regular keypad functions, within the users authorization level, for the requested partition.



Alarms in a partition are not displayed on LCD keypads unless the partition containing the alarm is addressed. Alarms in a partition cause the partition LED to pulse in LED keypads. The alarm sounder in the keypad will not sound unless the alarm occurs in the partition that the keypad is assigned to.

In addition to the normal partition requests (1 - 8) the following special functions are available:

**Arm All Partitions (0)**

To arm all of the partitions that you are authorized to operate in, enter a 0 into the partition request. If all of the partitions are READY, this function will arm all of the partitions in the AWAY mode from the single keypad. A message "ALL SYSTEMS ARMED AND SECURE" will appear to confirm the arming. If any of the partitions are NOT ready, then none of the partitions will be armed. In this situation the VIEW mode can be utilized and the status of each partition can be viewed and resolved (make zones ready, bypass zones, force arm etc.)

**View Mode (#)**

The View mode allows an authorized user to view the status of all partitions through the keypad. Simply enter a # from the partition selection display and the keypad will display the armed status for all active partitions that the user has been authorized. LCD keypads will show the following when the system is ready to be armed or will display the partitions armed when some or all partitions have been armed.

SYSTEM STATUS ARMED:
-------------------------

On LED keypads, the partitions that are disarmed illuminate LEDs 9-16 and partitions that are armed illuminate LEDs 1-8. The Bat, Stay, Rdy, Com, and Ins LEDs perform their normal function.

**Disarm All Partitions (9)**

To disarm all partitions from a single keypad enter 9 into the partition selection display. This command will disarm all partitions where that the user is authorized that are currently armed.

**Quick Arming [# 1]**

Depression of the # key followed by the digit 1 will ARM the system without entry of a user code. This is known as QUICK ARMING and will arm the system in the AWAY mode. This is identical to the ARMING command previously described. Note: System disarming still requires entry of a valid user code.

**Quick Forced Arming [ # 2]**

Force arming will arm the system and bypass any burglary zones that are not ready, without entry of a user code. Simply press the # key followed by the digit 2.

**Set Date/Time [# 3]**

The system contains a built in system time clock that may be set as follows:

- 1) Press # 3 on a LCD keypad. The system will display the following message.

System clock (1) Clock (2) Arm
-----------------------------------

To set the system clock, depress 1 on the keypad.

- 2) The system will display the current time as follows:

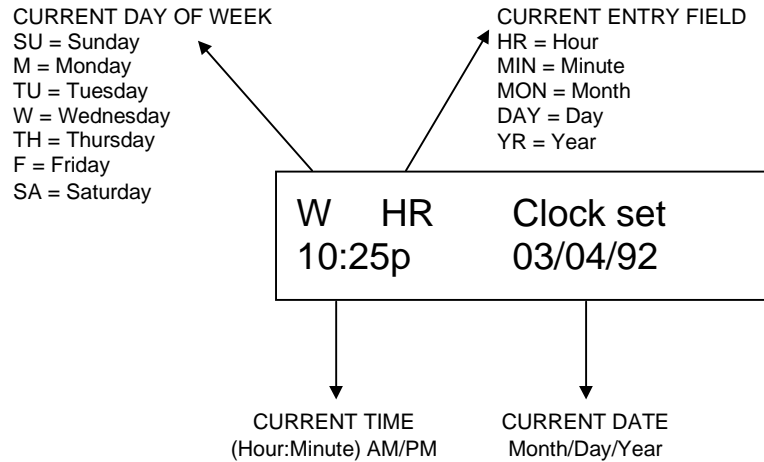

The top line shows the current time and the field being defined. The *INSTANT* key will be used to move between the fields and the *CODE* key is used to change between AM/PM.

- 3) Enter the current hour (00 - 12)
- 4) Press the *INSTANT* key and enter minutes (00 - 59). To change AM/PM, press the *CODE* key.



The *CODE* key must be depressed at least one time during the set clock procedure. If the key has not been depressed at least once, you will not be able to exit when you enter the \* at the end of this procedure.

- 5) Press the *INSTANT* key and enter the month (01 - 12)
- 6) Press the *INSTANT* key and enter the date (01 - 29)
- 7) Press the *INSTANT* key and enter the year (00 - 99)
- 8) Press \* to exit

**TIME SET EXAMPLE:**

Example: Set clock to 11:21 PM, December 21, 1992.

```
# 3
11 INSTANT 21 CODE
INSTANT 12 INSTANT 21 INSTANT 92 *
```

The system will automatically determine the day of the week and will adjust for leap year and daylight savings time if applicable. The system time must be reset if the AC power and battery have been removed.

**Partition Auto Arming By Day**

An auto arming schedule must be entered into the system when this function is enabled. To enter an auto arming schedule proceed as follows:

- 1) Enter #3 from the keypad. The keypad will display:

(1) clock (2) arm



The clock must be set prior to entering an auto arming schedule.

- 2) Press 2. The keypad will display:

Su AUTOARM HR 12:00 a Part 1
---------------------------------



---

The Part number will be the partition number the keypad is enabled in.

---

- 3) Set the hour by entering a number from 1 to 12 for the desired hour (HR).
- 4) Press the Instant key. The HR portion of the display will change to MIN.
5. Set the minute by entering a number from 0 to 59 for the desired minute (MIN).
- 6) Press the Code key to change from AM (a) to PM (p).



---

The CODE key must be depressed at least one time during this procedure. If the key has not been depressed at least once, you will not be able to exit when you enter the \* at the end of this procedure.

---

- 7) Press the Stay key to advance to the desired day of the week. Note that if the # key is pressed while in the auto arm mode, the display will show --:-- meaning that the time is disabled and there will be no auto arm for that day.
- 8) When all entries have been completed, press the \* to exit.

#### Zone Directory [# 4]

The LCD keypad can display descriptors of the zones connected to the system. To view the zone descriptors for your system simply press # 4 and the system will scroll the descriptors on the keypad. This command will display the descriptors for the zones associated with your partition only. To exit from the zone directory function, press any key from the keypad.

#### Quick Bypassing [# 5]

Bypassing can also be performed without entry of a user code through entry of # 5 followed by the three-digit zone number. For example to bypass zone 13 enter # 5 0 1 3. Note: The zone selected must be bypassable.

#### Chime Mode [# 6]

The system contains an optional chime feature which causes the keypad sounder to activate for one second every time selected zones such as an entrance door is opened while the system is disarmed. For example, this could be used to inform the end user each time that a selected opening such as an entrance door or patio door was opened. There is a programmable option per zone to select whether each zone can participate in the chime. To activate the chime feature Press # 6 then 0 to turn the chime mode on or off.

The LCD display shows the current CHIME status as follows:

CHIME is now ON 0 = OFF * = exit
-------------------------------------

In this example entry of a 0 will turn the system chime mode off, or the \* key will exit from the function.

#### Partition Assignment [ # 7 ]

The system has the ability to be broken into separate independent subsystems known as partitions. Each user code can be valid in one or more partitions. Normally partition assignments are made by the installer through any of the programming methods during the

initial system programming. This command allows authorized end users to modify the partition assignments for users. For example, a plant manager may have reason to create different user codes and change the areas of the plant (partitions) that each specific user can access.

The partition assignment function allows authorized users (level 1 & 2) to change the partition access of the various user codes. Note: A level 1 user will be able to change the partition assignment for users within all partitions, while a level 2 user can only change partition assignments within the partitions that he is permitted to access.

To enter the partition access section, enter # 7 followed by a level 1 or 2 user code.

(XL-4)

```
ENTER US# TO MAP
001-064, * EXIT
```

(XL-5)

```
ENTER US# TO MAP
001-128, * EXIT
```

Enter the user number (001 – 064 for the XL-4 or 001 – 128 for the XL-5) to be mapped to various partitions.

```
SET 1-8 *=EXIT XXX
PART 12345678
```

This display allows assignment or removal of users from each of the 8 partitions. The first line displays the user being modified (displayed as xxx). The second line shows the partitions where the user is currently active. For example, if the keypad shows 1 345 then the user is active in partitions 1 3 4 and 5. Entry of the partition number will toggle the state of that partition. If the user is already defined within that partition, entry of the number will remove that user, and vice versa. The display will reflect the current status (the partitions displayed reflect partitions where the user is active). Upon completion press the \* key.

## Log Dump Function

The control panel contains a feature that can automatically transmit the system activity log to a remote or local printer. This action can be programmed to occur on either a daily, weekly, or monthly basis.

### Remote Printer Option

If a remote printer is used for the log dump then the control panel will dial the telephone number defined as the DUMP phone number and transmit the log dump information at the defined interval.

In order to utilize the remote log dump printout, the following hardware must be present at the location where the DUMP telephone number is located:

**MODEM:** The modem must be a Bell 103 compatible (300 baud), with auto answer capability. These options must be selected through the dip switches or configuration settings of the modem. The modem tested by Fire Burglary Instruments is the Hayes Smartmodem.

**PRINTER:** The printer connected to the modem must contain a serial interface capable of operation at 300 baud, 8 data bits, one stop bit, no parity.

Since log dumps can occur at various times of the day it is strongly recommended that this hardware and the dump telephone number be dedicated and not shared for other applications. Note: This function has not been investigated by Underwriters Lab,

### Local Printer

A serial printer can be used at the control panel location to obtain a printout of the system log dump information. This requires the use of the FBII model 7130 Serial Printer Interface Module connected to P1.

Local printer output will occur regardless of a remote log dump transmission if the DUMP telephone number is defined or a null value (blank) through keypad or remote programming. The control panel will output the system log information based on the frequency

programmed (daily, monthly, weekly, # events). Note: To obtain a printout after each event, program the number of events to 1.

The local printer at the control panel location must have the following characteristics: Serial printer, 300 baud, 8 data bits, one stop bit, and no parity.

## Keypad Function Summary

### End User Functions

<u>PROCEDURE</u>	<u>KEY SEQUENCE</u>
ARM SYSTEM	[USER]
STAY	STAY [USER]
INSTANT	INSTANT [USER]
INSTANT-STAY	INSTANT STAY [USER] or STAY INSTANT [USER]
BYPASS	BYPASS [USER] [ZN]
GROUP BYPASS	BYPASS [USER] * 1 [ZN]
BYPASS multiple	BYPASS [USER] [ZN] BYPASS [ZN] BYPASS [ZN] .....
UNBYPASS	BYPASS [USER] [ZN]
UNBYPASS multiple	BYPASS [USER] [ZN] BYPASS [ZN] BYPASS [ZN] .....
GROUP UNBYPASS	BYPASS [USER] * 2 [ZN]
FORCED ARMING	BYPASS [USER] BYPASS
DISARM	[USER]
USER DEFINITION	CODE[USER][US#][USID][LEV]
MULTI-PARTITION	# 0 [USER] p            0=Arm all partitions, 9=Disarm all
QUICK ARM	# 1
QUICK FORCED ARM	# 2
TIME DATE Set	# 3
ZONE DIRECTORY	# 4                    [NOTE: LCD Keypads Only]
QUICK BYPASS	# 5 ZN
CHIME MODE	# 6
USER PART. ASSIGNMENT	# 7 [USER]

### Installer Functions

<u>PROCEDURE</u>	<u>KEY SEQUENCE</u>
KEYPAD PROGRAMMING	CODE * [INSTALLER CODE] 1
TIME/DATE SETUP	CODE * [INSTALLER CODE] 2
WALK TEST w/o BELL†	CODE * [INSTALLER CODE] 3
WALK TEST with BELL†	CODE * [INSTALLER CODE] 4
DEFAULT RESET	CODE * [INSTALLER CODE] 5
SYSTEM LOG VIEW	CODE * [INSTALLER CODE] 6

† = LCD KEYPADS ONLY

Keypad programming is exited by \* and #, all other functions are exited by the \* alone.

# Installer Functions

## In This Section

- ◆ Keypad Programming
- ◆ Time Date Setup
- ◆ Walk Test
- ◆ Walk Test With Bell Output
- ◆ Default Reset
- ◆ System Log View

The control panel contains functions reserved for the installer to be used during the initial installation and subsequent troubleshooting of the panel. Entry into the installer mode is protected by a six-digit installer code that can be programmed for each installing company. The default value for the installer code is 123456.

Entry into the installer mode requires the following sequence:

CODE \* [INSTALLER CODE] x

where:

CODE	is the CODE key on the keypad
*	is the asterisk key
[INSTALLER CODE]	is the six-digit installer code
x	is the desired function as follows:
	1 Keypad Programming *
	2 Time/Day Setup
	3 Walk Test *
	4 Walk Test with Bell Output *
	5 Default Reset
	6 System Log View *
	* LCD Keypad Only



The system must be in a disarmed state in order to perform any of the installer functions.

## Keypad Programming

Keypad programming can only be performed through a LCD keypad. If the installed system does not include any LCD keypads then a LCD keypad can be connected temporarily for programming purposes. Alternately programming can be performed remotely through the EZ-MATE Downloader. For information regarding keypad programming consult the LCD Keypad Programming Guide.

## Time Date Setup

This function allows the installer to modify the system date and time without use of a user code.

**Time Date Setup Procedure**

**CODE [INSTALLER CODE] 2**

This will generate similar keypad displays as the end user procedure. See time/date section for more details.

**Walk Test**

The walk test function provides the ability to test the zones that have been programmed within the system. The walk test has options to display the zones that require testing as well as displaying the zones that have been tested.

The zones to be tested during the walk test will depend on the system. Based on the system expansion module installed, the following zones will be tested:

No expander	Zones 1-8 only
7015 (Hardwired expansion)	Zones 1-16
7120 expander (XL-4/XL-B)	Zones 1 - 72 (Zones 1-8 Hardwired, zones 9-72 multiplex)
7126 expander (XL-5)	Zones 1 - 128 (Zones 1-8 Hardwired, zones 9-128 multiplex)

**Walk Test Procedure**

**CODE \* [INSTALLER CODE] 3**

Depress the CODE key followed by the \* key, and your six-digit installer code. A display will appear indicating that you have entered the installer walk test mode.

The following display will appear:

WALK TEST MODE

WALK TEST    Zne 004  
MASTER BEDROOM

The initial walk test mode will scroll through a list of the zones that have not been tested. The first line of the display shows the zone number and the second line contains the zone description. The zones included in the list depend on the programming option for zone expansion. Note: If the multiplex expander module is present (model 7120 or 7126) then the zones tested will depend on the zone expansion option selected.

At this point the individual zones can be tripped to test their operation. As each zone is violated the keypad will emit a sound every time a zone has been violated and/or restored. As each zone is tested the zone will be removed from the scrolling loop of zones that have not been tested.



---

Walk test can only be performed on LCD keypads.

---

The walk test mode will automatically terminate after approximately 5 minutes without any testing activity and the system will return to the previous system status.

**Display Tested Zones**

To display the zones already tested press the # key. This will scroll through the zones that have already been tested as follows:

Tested            Zne 006  
DINING ROOM

In this mode the keypad will scroll the zones that have already been tested. Depression of the # key will return to the previous displays showing the zones that still require testing.

---

To exit the walk test mode press the \* key. This will return to the previous state of the panel prior to the Walk Test.

## Walk Test With Bell Output

This function is identical to the normal walk test function except the bell will be activated with each zone violation. This mode might be used in a large facility where the keypads are not located within close enough proximity to the zones.

### Walk Test With Bell Output Procedure

**CODE \* [INSTALLER CODE] 4**

## Default Reset

The control panel is shipped with factory default values that reflect a common installation. These values can be modified through LCD keypad programming or the EZ-Mate Downloader. The default values are shown in the System Default section of the LCD Keypad Programming Guide.

The DEFAULT RESET function will return the system to the default values. This will replace any of the values that have already been modified within the programming sequence.

### Default Reset Procedure:

**CODE \* [INSTALLER CODE] 5**

Upon selecting the system default function the following display will appear:

```
SYSTEM DEFAULT
5 = YES, * = NO
```

To perform the system default enter 5, to exit press \*.

The default procedure may take up to 30 seconds as the default values are being read into the panel. After completion the panel will reset and return to the current panel status.



The default value reset should only be performed as a last resort if the programming state of the panel is unknown. After performing the default reset the programming options should be reviewed to reflect the characteristics of the installation.



If the INSTALLER LOCKOUT option has been selected within the programming sequence then a default reset through these pins will perform a default with the exception of the CSID and Installer Code.

The default reset function can also be performed by shorting the DEFAULT RESET (TP1 TP2) pins directly on the control panel.

## System Log View

The control panel contains a feature that retains the last 128 events. This system event log can be read directly through a LCD keypad or retrieved externally using the EZ-Mate PC Software.

Entry into the system log view can be performed as follows:

**CODE \* [INSTALLER CODE] 6**

Upon entry to the log view function the following display will appear:

```
LOG:<STAY>= CONT
# clear , * exit
```

The following keystrokes can be used within the system log view function:

**STAY** Advances to the next system log entry

- BYPASS Scroll in reverse through the system log
- # Clear the log
- \* Exit from the log view function

The list below shows the entries that can appear in the system log. These items will appear on the second line of the display, the first line contains the time and date of the entry. Note: The items shown in lower case letters will contain the actual zone number or partition based on the type of message.

<u>LOG MESSAGE</u>	<u>EXPLANATION</u>
ALARM Key pz p	Keypad emergency conditions. pz = keypad condition 1-4, p = partition
ALARM Zone zn p	Zone alarm zn = actual zone, p = partition
TROUBLE zn p	Trouble condition zn = actual zone p = partition
BYPASS us zn p	Bypass us = user performing the bypass, zn = zone bypassed, p = partition
UNBYP us zn p	Unbypass us = user performing they unbypass, zn = zone unbypassed, p = partition
P Prog us p	User code change us = User #, P = Partition
RESTORE K pz p	Restore of keypad emergency conditions. pz = keypad condition 1-4, p = partition
RESTORE Z zn p	Restore of zone. zn = actual zone, p = partition
Trb Rstr zn p	Restore of trouble condition an = zone number, p = partition
SYS TRBL	System trouble such as AC loss, Low Battery or System Error
SYS RSTR	System restore of condition such as AC Loss, Low Battery, System Error.
OPEN us p	Opening us = user performing the opening p = partition
CLOSE us p	Closing us = user performing the closing p = partition
CODE/RESET xx p	System abort or user code entered to leave alarm view mode
CS TEST REPORT	System test transmitted to Central Station
DOWNLOAD	Indicates that a download has take place.
AMBUSH us p	Indicates that an ambush code has been entered us = user number p = partition
LOG DUMP Request	Indicates that an attempt has been made to transmit the system log to the Dump telephone number.
CALLBACK Request	Indicates that a remote communications session requiring a callback was made.
Clock Set	Indicates system time/date was changed. The entry on the first line displays the revised system time.
ANSWERED Telcall	Shows that the panel has picked up the telephone line in response to a remote communication request.
ENDED Telcall	Indicates that a remote communications session has ended.
Key Programming	Indicates that keypad programming has been entered.
AC Loss	Indicates AC loss
Low Batt	Indicates Low Battery
Grd Fault	Indicates ground fault
Sys Error	Indicates System Error
Tamper zn p	Indicates a tamper condition sensed on a multiplex point zn = zone, p = partition
Tmp Restore zn p	Restore of tamper condition on a multiplex point. zn = zone number, p = partition

Extra zone zn	Indicates that an additional multiplex zone has been seen on the multiplex loop that was not defined within the programming sequence.
Supervisor zn p	Indicates a supervisory failure on a multiplex point. zn = zone number , p = partition
Sup Restore zn p	Indicates that multiplex points that previously not heard from have resumed communications with the control panel. ZN = zone number, p = partition
Abort us zn	Abort condition sent us = user number
Stop on Abort p	Indicates that an abort took place and no transmission took place. p = partition
Restore on Abort p	Indicates that an abort occurred and a restore signal was transmitted. p = partition
Comm Failure	Communications failure with CS
Stay Arm us p	Indicates that a STAY arming was performed. us = User, p = partition
Auto Stay Arm	Indicates that an Auto Stay arm was performed.
Group Bypass us gp	Indicates that a group bypass was performed. us = User code gp = group number
Group Unbypass us gp	Indicates that a group unbypass was performed. us - User code, gp = group number
End of Report	Indicates the end of the system log.

**Examples Of System Log Displays:**

Jul 12 12:18 TROUBLE 02 1
------------------------------

Trouble in zone 2 within partition 1 at 12:18 on July 12. Note: All times are displayed in military (24 hour) time.

Aug 01 16:15 BYPASS 11 02 1
--------------------------------

Bypass performed by user 11 on zone 2 within partition 1 at 16:16 (4:15PM) on August 1.



## WARNING

### LIMITATIONS OF THIS ALARM SYSTEM

While this system is an advanced design security system, it does not offer guaranteed protection against burglary, fire or other emergency. Any alarm system, whether commercial or residential, is subject to compromise or failure to warn for a variety of reasons. For example:

- Intruders may gain access through unprotected openings or have the technical sophistication to bypass an alarm sensor or disconnect an alarm warning device.
- Intrusion detectors (e.g., passive infrared detectors), smoke detectors, and many other sensing devices will not work without power. Battery operated devices will not work without batteries, with dead batteries or if the batteries are not put in properly. Devices powered solely by AC will not work if their AC power supply is cut off for any reason, however briefly.
- Signals sent by wireless transmitters may be blocked or reflected by metal before they reach the alarm receiver. Even if the signal path has been recently checked during a weekly test, blockage can occur if a metal object is moved into the path.
- A user may not be able to reach a panic or emergency button quickly enough.
- While smoke detectors have played a key role in reducing residential fire deaths in the United States, they may not activate or provide early warning for a variety of reasons in as many as 35% of all fires, according to data published by the Federal Emergency Management Agency. Some of the reasons smoke detectors used in conjunction with this System may not work are as follows: Smoke detectors may have been improperly installed and positioned. Smoke detectors may not sense fires that start where smoke cannot reach the detectors, such as in chimneys, in walls, or roofs, or on the other side of closed doors. Smoke detectors may not sense a fire on another level of a residence or building. A second floor detector, for example, may not sense a first floor or basement fire. Moreover, smoke detectors have sensing limitations. No smoke detector can sense every kind of fire every time. In general, detectors may not always warn about fires caused by carelessness and safety hazards like smoking in bed, violent explosions, escaping gas, improper storage of flammable materials, overloaded electrical circuits, children playing with matches, or arson. Depending on the nature of the fire and/or the location of the smoke detectors, the detector, even if it operates as anticipated, may not provide sufficient warning to allow all occupants to escape in time to prevent injury or death.
- Passive Infrared Motion Detectors can only detect intrusion within the designed ranges as diagrammed in their installation manual. Passive Infrared Detectors do not provide volumetric area protection. They do create multiple beams of protection, and intrusion can only be detected in unobstructed areas covered by the beams. They cannot detect motion or intrusion that takes place behind walls, ceilings, floors, closed doors, glass partitions, glass doors, or window. Mechanical tampering, masking, painting, or spraying of any material on the mirrors, windows or any part of the optical system can reduce their detection ability. Passive Infrared Detectors sense changes in temperature; however, as the ambient temperature of the protected area approaches the temperature range of 90 to 150F, the detection performance can decrease.
- Alarm warning devices such as sirens, bells or horns may not alert people or wake up sleepers who are located on the other side of closed or partly open doors. If warning devices sound on a different level of the residence from the bedrooms, then they are less likely to waken or alert people inside the bedrooms. Even persons who are awake may not hear the warning if the alarm is muffled by noise from a stereo, radio, air conditioner or other appliances, or by passing traffic. Finally, alarm warning devices, however loud, may not warn hearing-impaired people or waken deep sleepers.
- Telephone lines needed to transmit alarm signals from a premises to a central monitoring station may be out of service or temporarily out of service. Telephone lines are also subject to compromise by sophisticated intruders.
- Even if the system responds to the emergency as intended, however, occupants may have insufficient time to protect themselves from the emergency situation. In the case of a monitored alarm system, authorities may not respond appropriately.
- This equipment, like other electrical devices, is subject to component failure. Even though this equipment is designed to last as long as 10 years, the electronic components could fail at any time.

The most common cause of an alarm system not functioning when an intrusion or fire occurs is inadequate maintenance. This alarm system should be tested weekly to make sure all sensors are working properly.

Installing an alarm system may make one eligible for lower insurance rates, but an alarm system is not a substitute for insurance. Homeowners, property owners and renters should continue to act prudently in protecting themselves and continue to insure their lives and property.

We continue to develop new and improved protection devices. Users of alarm systems owe it to themselves and their loved ones to learn about these developments.

## **"FEDERAL COMMUNICATIONS COMMISSION (FCC) STATEMENT"**

This equipment has been tested to FCC requirements and has been found acceptable for use. The FCC requires the following statement for your information.

This equipment generates and uses radio frequency energy and if not installed and used properly, that is in strict accordance with the manufacturer's instructions may cause interference to radio and television reception. It has been tested and found to comply with the limits of Part 15 of FCC Rules, which are designed to provide reasonable protection against such interference in a residential installation. However, there is no guarantee that interference will not occur in a particular installation. If this equipment does cause interference to radio or television reception, which can be determined by turning the equipment off and on, the user is encouraged to try to correct the interference by one or more of the following measures:

- If using an indoor antenna, have a quality outdoor antenna installed.
- Reorient the receiving antenna until interference is reduced or eliminated.
- Move the radio or television receiver away from the control/communicator.
- Move the antenna leads away from any wire runs to the control/communicator.
- Plug the control/communicator into a different outlet so that it and the radio or television receiver are on different branch circuits.

If necessary, the user should consult the dealer or an experienced radio/television technician for additional suggestions.

The user may find the following booklet prepared by the Federal Communications Commission helpful:

"Interference Handbook"

This booklet is available from the U.S. Government Printing Office, Washington, DC 20402. Stock No. 004-000-00450-7.

**The user shall not make any changes or modifications to the equipment unless authorized by the installation Instructions or User's Manual. Unauthorized changes or modifications could void the user's authority to operate the equipment.**

## **IN THE EVENT OF TELEPHONE OPERATIONAL PROBLEMS**

In the event of telephone operational problems, disconnect the communicator by removing the plug from the RJ31X jack. Do not disconnect the phone connection inside the communicator; doing so will result in the loss of the telephone. If the telephone works correctly after the communicator has been disconnected from the phone lines, the communicator has a problem and should be returned for repair.

If upon disconnecting the communicator, there is still a problem on your line, notify the telephone company that they have a problem and request prompt repair service. The user may not under any circumstances (in or out of warranty) attempt any service or repairs on the system. It must be returned to the factory or an authorized service agency for all repairs.

## **FBI LIMITED WARRANTY**

Fire Burglary Instruments Inc., a Subsidiary of Pittway Corporation, and Pittway Corporation its divisions, subsidiaries, and affiliates ("Seller"), 149 Eileen Way, Syosset, New York 11791, warrants its products to be in conformance with its own plans and specifications and to be free from defects in materials and workmanship under normal use and service for five years from the date stamp control on the product, or for products not having a date stamp, for twelve months from the date of original purchase unless the installation instructions or catalog sets forth a shorter period, in which case the shorter period shall apply. Seller's obligation shall be limited to repairing or replacing, at its option, free of charge for materials or labor, any part which is proved not in compliance with Seller's specifications or proves defective in materials or workmanship under normal use and service. Seller shall have no obligation under this Limited Warranty or otherwise if the product is altered or improperly repaired or serviced by anyone other than Seller. For warranty service, return transportation prepaid, to Factory Service, 149 Eileen Way, Syosset, New York 11791.

THERE ARE NO WARRANTIES, EXPRESSED OR IMPLIED, OF MERCHANT ABILITY, OR FITNESS FOR A PARTICULAR PURPOSE OR OTHERWISE, WHICH EXTEND BEYOND THE DESCRIPTION ON THE FACE HEREOF. IN NO CASE SHALL SELLER BE LIABLE TO ANYONE FOR ANY CONSEQUENTIAL OR INCIDENTAL DAMAGES FOR BREACH OF THIS OR ANY OTHER WARRANTY, EXPRESS OR IMPLIED, OR UPON ANY OTHER BASIS OF LIABILITY WHATSOEVER, EVEN THE LOSS OR DAMAGE IS CAUSED BY ITS OWN NEGLIGENCE OR FAULT.

Seller does not represent that the products it sells may not be compromised or circumvented; that the products will prevent any personal injury or property loss by burglary, robbery, fire or otherwise; or that the products will in all cases provide adequate warning or protection. Customer understands that a properly installed and maintained alarm system may only reduce the risk of a burglary, robbery, or fire without warning, but it is not insurance or a guarantee that such will not occur or that there will be no personal injury or property loss as a result. CONSEQUENTLY, SELLER SHALL HAVE NO LIABILITY FOR ANY PERSONAL INJURY, PROPERTY DAMAGE OR OTHER LOSS BASED ON A CLAIM THE PRODUCT FAILED TO GIVE ANY WARNING. HOWEVER, IF SELLER IS HELD LIABLE, WHETHER DIRECTLY OR INDIRECTLY, FOR ANY LOSS OR DAMAGE ARISING UNDER THIS LIMITED WARRANTY OR OTHERWISE, REGARDLESS OF CAUSE OR ORIGIN, SELLER'S MAXIMUM LIABILITY SHALL NOT IN ANY CASE EXCEED THE PURCHASE PRICE OF THE PRODUCT, WHICH SHALL BE THE COMPLETE AND EXCLUSIVE REMEDY AGAINST SELLER.

This warranty replaces any previous warranties and is the only warranty made by Seller on this product. No increase or alteration, written or verbal, of the obligations of this Limited Warranty is authorized.



# Index

7103UL.....	See Trigger Cable Assembly
7105.....	See Hardwire Expansion
7120.....	See Polling Loop Expansion
7126.....	See Polling Loop Expansion
7130.....	See Serial Interface Module
7700.....	See EZ-Mate PC Downloader
Accessories.....	2-1
Auxiliary Power.....	3-8
Battery Backup.....	3-13
Bypass.....	5-7
Control Panel Wiring Diagram.....	3-2
Control Panels.....	2-1
Date Time Setup.....	6-1
Default Reset.....	3-9, 6-3
Disarming.....	5-12
Duress/Ambush.....	5-13
Expansion Modules.....	2-1
EZ-Mate PC Downloader	
7700.....	2-1
Forced Arming.....	5-8
Ground Connection.....	3-9
Group Bypass.....	5-9
Group Unbypass.....	5-10
Groups.....	5-9
Hardwire Expansion	
7105.....	1-1, 2-1, 3-4
Hardwired Zone Expander Installation.....	3-4
INSTANT.....	5-6
INSTANT-STAY.....	5-7
JP1.....	3-8
JP2.....	3-9
Keypad Addressing.....	3-6
Keypad Auxiliary Conditions.....	5-12
Keypad Connections.....	3-6
Keypad Function Keys.....	5-4
Keypad Function Summary.....	5-18
Keypad Layout.....	5-1
Keypad Mounting.....	3-13
Keypad Programming.....	6-1
Keypads.....	2-1
XK-516.....	2-1, 3-6, 5-1
XK-5LC.....	2-1, 3-6, 5-1
XK-716.....	2-1, 3-6, 5-1
XK-7LC.....	2-1, 3-6, 5-1
LCD Keypad Programming Mode.....	5-13
Log Dump Function.....	5-17
Multiplex Expander Installation.....	4-1
Multiplex Peripherals.....	2-2
XL-4701.....	2-2, 4-4
XL-4702.....	2-2, 4-4
XL-4708.....	2-2, 4-4
XL-4722.....	2-2, 4-4
XL-4750SDT.....	2-2, 4-4
ZR-745MSL.....	2-2, 4-4
ZR-750MOH.....	2-2, 4-4
ZR-795MR.....	2-2, 4-4
Multiplex Zone Expander Installation.....	3-5
Panel Reset.....	3-9
Polling Loop Expansion	
7120.....	1-1, 2-1, 3-4, 3-5, 4-1, 4-2, 6-2
7126.....	1-1, 2-1, 3-4, 3-5, 4-1, 4-2, 6-2
Polling Loop Overview.....	4-2
Programmer Connection.....	3-8
Quick Commands.....	5-13
Related Documentation.....	1-2
Relay #1.....	3-10
Relay #2.....	3-11
Relay Module.....	2-2
XL-4705.....	2-2, 3-12
Sample LCD Display.....	5-4
Serial Interface Module	
7130.....	2-1, 3-9, 5-17
Smoke Detector Reset.....	3-11
STAY.....	5-6
System Log View.....	6-3
Tamper Switch.....	3-10
Telephone Line Connection.....	3-9
Time Date Setup.....	6-1
Transformer Connection.....	3-13
Trigger Cable Assembly	
7103UL.....	2-1, 3-12
Trigger Connector.....	3-12
UL Listings.....	1-2
Unbypass.....	5-8
User Deletion.....	5-11
User Programming.....	5-10
View System Log.....	6-3
Walk Test.....	6-2
Walk Test With Bell Output.....	6-3
Wiring Diagram	
Control Panel.....	3-2
XK-516.....	See Keypads
XK-5LC.....	See Keypads
XK-716.....	See Keypads
XK-7LC.....	See Keypads
XL-4701.....	See Multiplex Peripherals
XL-4702.....	See Multiplex Peripherals
XL-4705.....	See Relay Module
XL-4708.....	See Multiplex Peripherals
XL-4722.....	See Multiplex Peripherals
XL-4750SDT.....	See Multiplex Peripherals
Zone Hookup.....	3-4
ZR-745MSL.....	See Multiplex Peripherals
ZR-750MOH.....	See Multiplex Peripherals
ZR-795MR.....	See Multiplex Peripherals



FIRE BURGLARY INSTRUMENTS INC.  
Subsidiary of Pittway Corp.

**149 Eileen Way, Syosset, New York 11791**  
Copyright © 1998 PITTWAY CORPORATION



**N9144V1 10/98**