

Fire Burglary Instruments, Inc.

50 Engineers Road, Hauppauge, New York 11787



INSTALLATION INSTRUCTIONS

Remember... "We do what they don't"

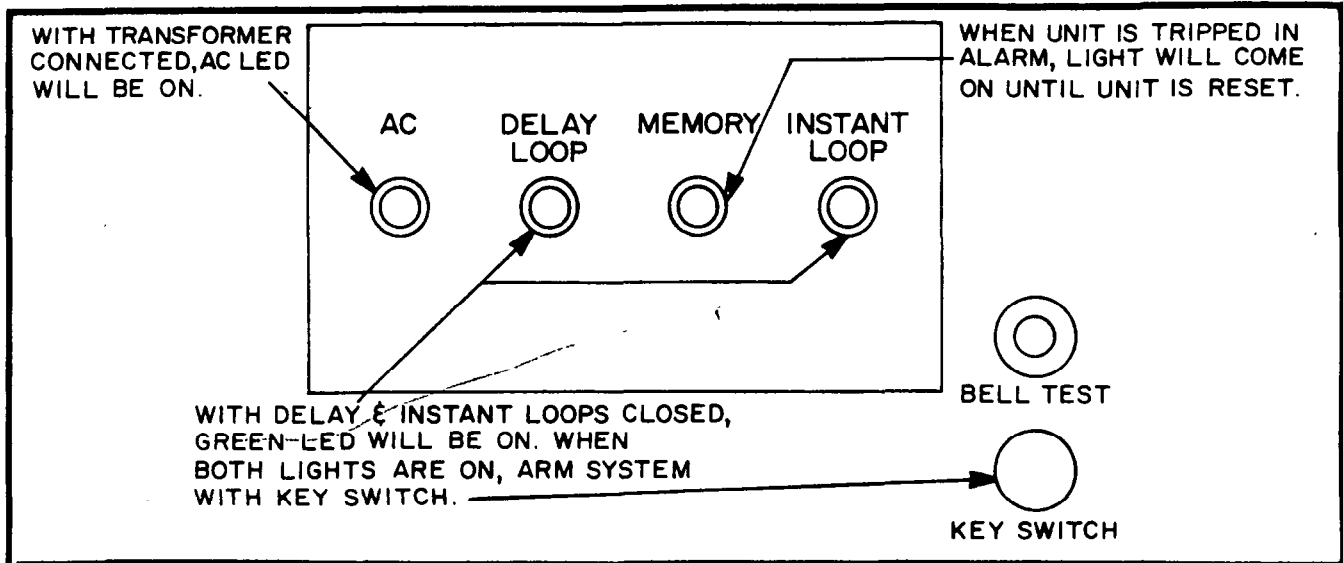

TERMINALS	DESCRIPTIONS
1 & 2	12VAC 20VA Input: Connect 1271 transformer (supplied) to 24 hour power outlet: wire output of transformer to 1 & 2 using 18 gauge wire.
3(+) & 4(-)	Sonalert: Early warning indication for entrance-exit circuit. Use 515/872.
5(+) & 4(-)	Bell output is 12 volts on burglary or panic. Use 18 gauge wire.
6 & 7	Open circuit contact that closes when burglary or panic circuit is activated. Use for dialer, siren, etc. (5 AMP, 110VAC).
8 & 9(+)	Secondary Circuit "Back-up System": Use open circuit devices only. After the system goes into bell cut-off & instant or delay loop remains open, a closure on the back-up system will cause the bell to ring again. USE FOR INTERIOR PROTECTION. See Note A for 3 wire connection to instant loop & back-up system.
9(+) & 15(-)	Continuous 12 Volt Power: Total current draw from panel is 1.5 AMPS, therefore, whatever current is not being drawn by devices connected to other terminals will be available here.
10 & 4(-)	24 Hour Panic Circuit: A latching closure will cause panel to go into alarm as long as closure is maintained. Use latching panic remote station 885.
11(+) & 12	Instant Loop: Closed protective circuit. Maximum resistance 1000 ohms. Green L.E.D. on when loop closed.
12 & 15(-)	Instant Loop: Open protective circuits (mats, etc.).
14 & 15(-)	Delay Loop: Wire closed delay circuit to these terminals. Maximum resistance 300 ohms. Green L.E.D. on when loop closed.
13 & 15	Key Switch Terminals: #510 shunt lock may be installed in hole provided on control box to turn system on/off. Use #22 wire or larger.
Loose Wires	Red: Connect to positive of rechargeable battery (use snap-on clip). Black: Connect to negative of rechargeable battery (use snap-on clip).
Panel Switches	Bell Test: Momentary button. With panel unarmed, bell will sound as long as button is depressed. With panel armed, bell will come on when button is depressed and remain on until panel is disarmed.

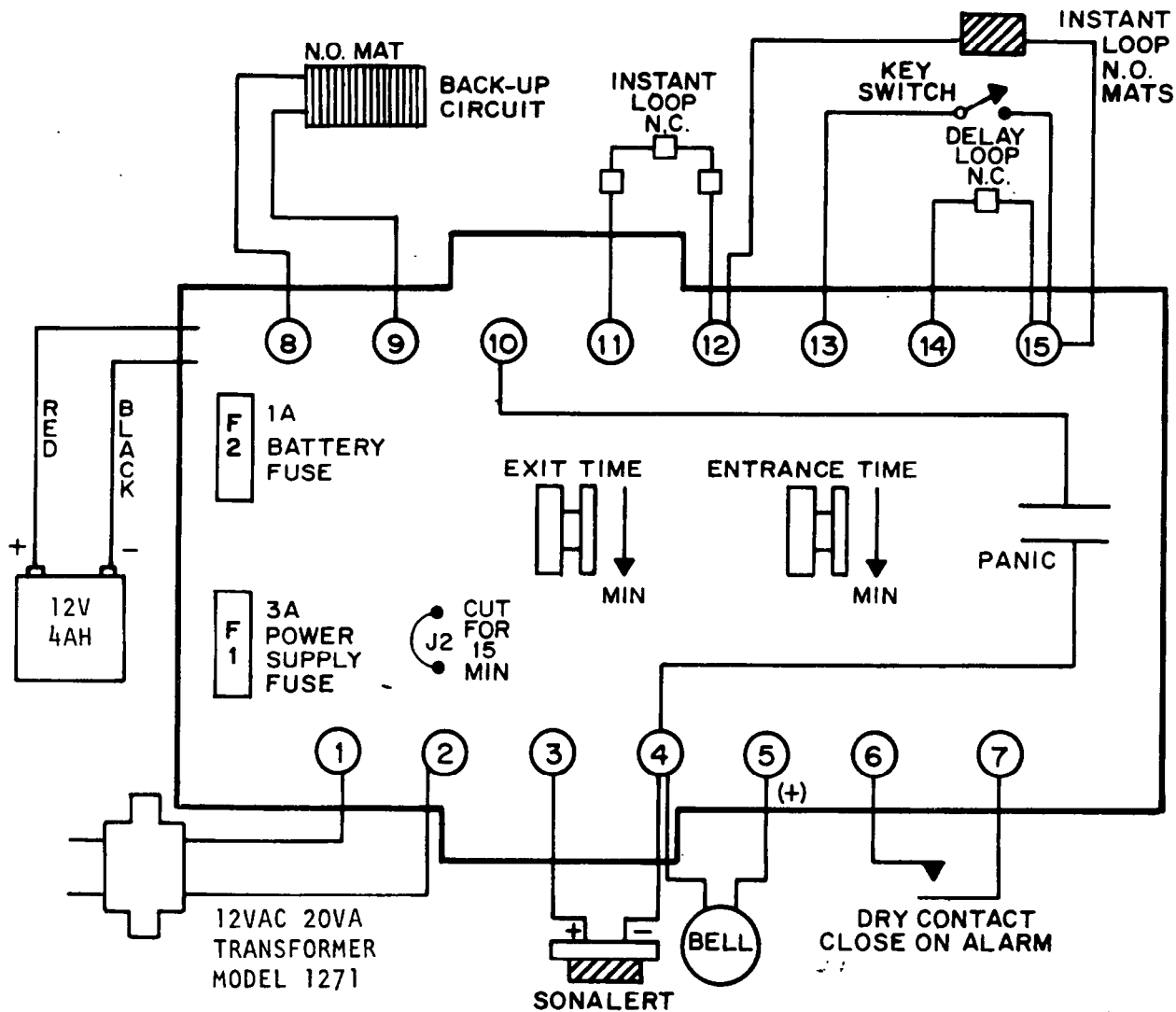

EXIT/ENTRANCE ADJUSTMENT PROCEDURE

1. Turn exit pot towards minimum.
2. Turn entrance pot towards maximum.
3. Test delay loop by putting a voltmeter or sonalert on terminals 3 & 4. Close the protective and delay loops and set the system to the "armed" condition. Now open delay door or remove connection to terminal 14; a reading of 15-17v should appear on terminals 3 & 4; or the sonalert should sound. This indicates that the delay loop is operating properly.
4. Exit Time is set for the desired delay period by turning the pot towards the top of the board. A 1/4 turn of the pot will yield about 20-30 seconds. Start timing the exit delay as soon as the system is "armed". Now open the delay door or remove the connection to terminal 14. Once again, wait for 15-17v to appear on terminals 3 & 4, or the sonalert to sound. This period is the exit time. To increase the exit time, turn the pot further towards the top of the board.
5. Entrance Time - From the time the sonalert sounds or 15-17v appear on terminals 3 & 4 to the time the bell rings is the entrance time. With the pot turned towards the top of the board, the entrance time is set to maximum. To decrease the time, turn the pot towards the bottom of the board.

NOTE A

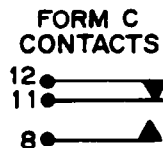

BELL CUT-OFF/RECYCLE TIME

Factory set for 30-50 seconds. With J2 cut 12-18 minutes

If loop is closed, (instant or delay), the bell will stop and the system will recycle. If the loop remains open, the bell will stop but the system will not recycle until the loop is restored. With the loop open and the bell cut off, the secondary back-up system is now active. A closure on this circuit will cause the alarm to activate.