

S P E C I F I C A T I O N S

**Beacon 3PLUS
Passive Infrared Detector**

STANDARD FEATURES:

- Low noise dual element detector
- SMD technology construction
- Temperature Compensation
- Selectable Pulse count (1,2 or 3)
- Walk test LED with Disable
- Tamper switch protection
- Built in wiring channel for simplified installation
- Reverse polarity Protection
- Interchangeable lenses include:
 - B3PLUS - LR Long Range Lens
 - B3PLUS - CL Curtain Lens
 - B3PLUS - PA Pet Alley Lens

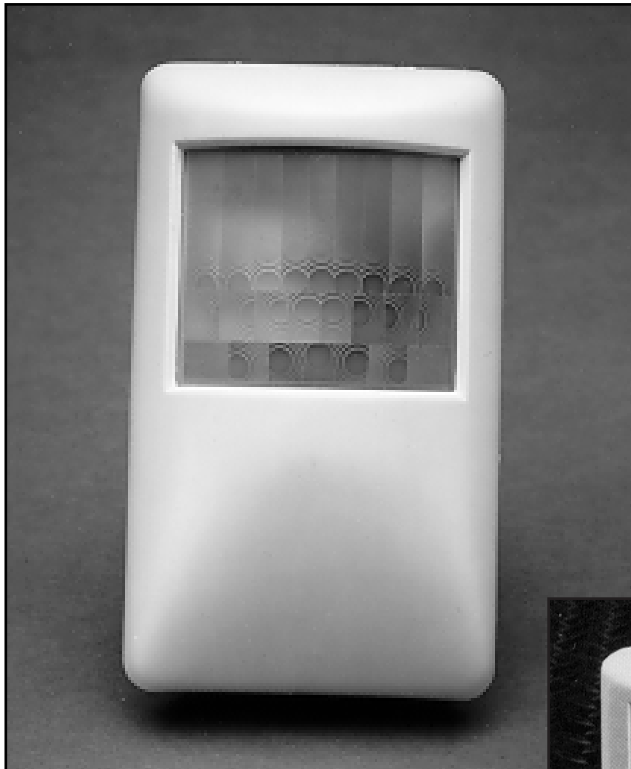

Beacon 3PLUS passive infrared detector

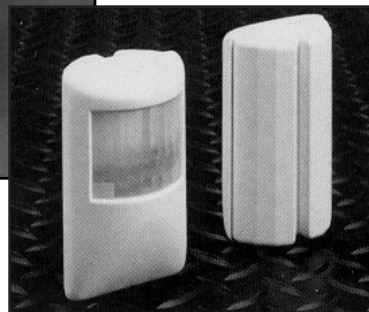

Wiring channel permits easy installation. Beveled rear cover allows precise corner mounting.

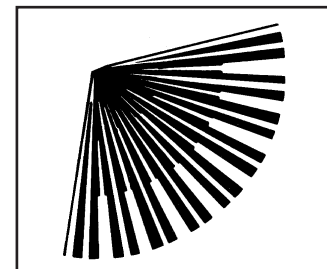

Standard Lens Pattern - 24 zones

SPECIFICATIONS

Detection Method	Passive Infrared
Coverage	55' x 55', 140° (with standard lens)
Detection Zones	24 Zones (11 long, 8 intermediate, 5 short)
Pulse Count	Installer selectable at 1, 2, or 3 event
Vertical Adjustment	Up to +5 or -15 degrees
Alarm Indicator	Red LED with enable/disable link
Mounting Height	7 ft nominal
Input Voltage	9 - 16 VDC
Power Consumption	15 mA at 12V
Relay Output	Normally closed dry contacts with 10 ohm resistor in series
Alarm Duration	1 second minimum
Tamper Switch	Normally closed dry contacts
Operating Temperature	14° F to 122° F (-10° C to 50° C)

Operating Humidity	Up to 95% relative humidity (max) non condensing
Dimensions	4.1" x 2.1" x 2.4" (105mm x 54mm x 60mm)

HOW TO ORDER

Beacon -3PLUS	Passive Infrared Detector, Dual Element
Accessory Lenses:	
B3PLUS-LR	Long Range Lens
B3PLUS-CL	Curtain Lens
B3PLUS-PA	Pet Alley Lens

Beacon 3PLUS LENS PATTERNS

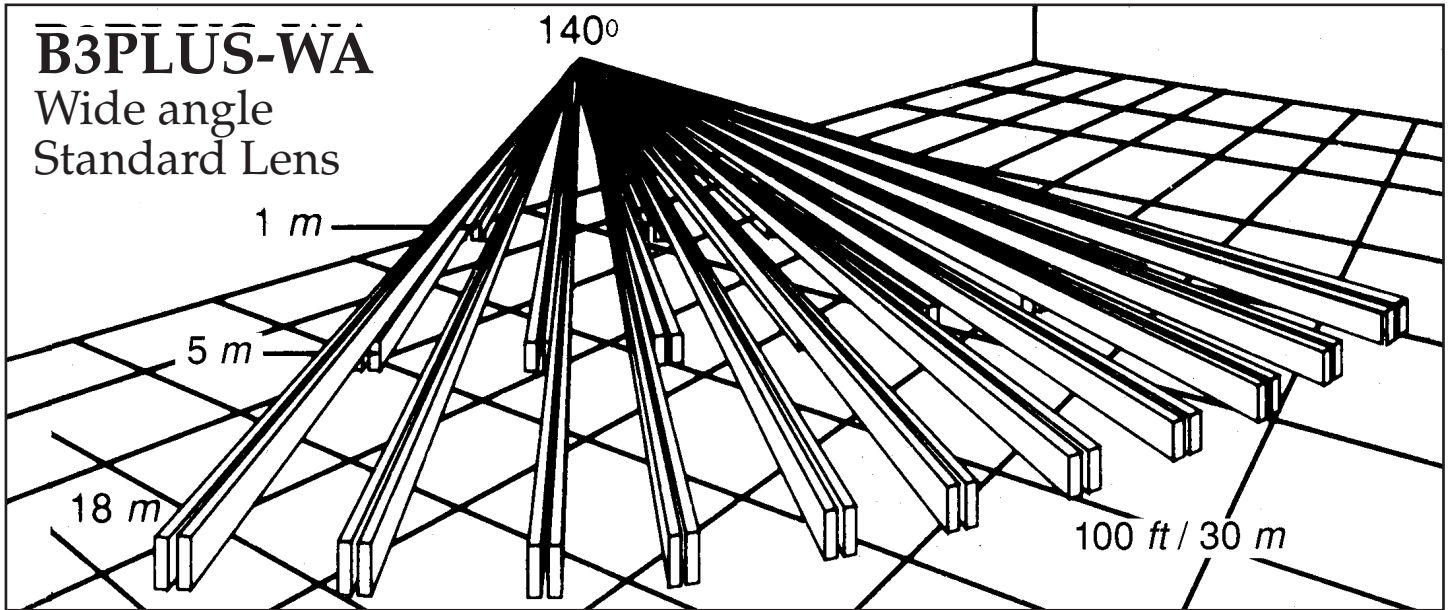

ACCESSORY LENSES

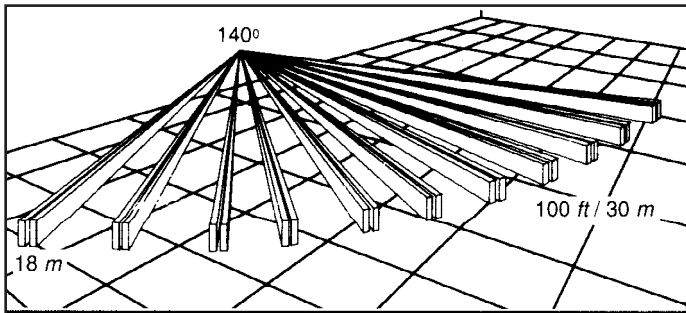

B3PLUS-PA
Pet alley

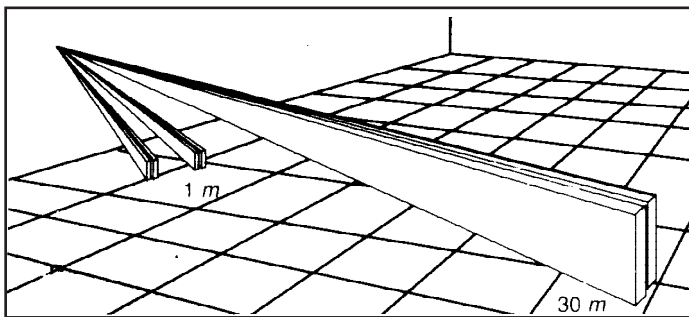

B3PLUS-LR
Long range

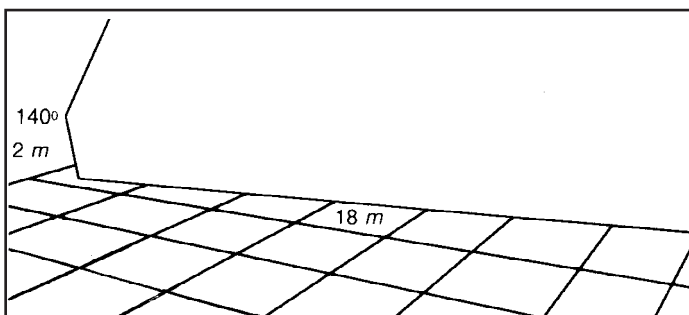

B3PLUS-CL
Curtain

Warranty valid within North America



FIRE BURGLARY INSTRUMENTS, INC.

A Subsidiary of Pittway Corp.

149 Eileen Way, Syosset, NY 11791

800-645-5430 • 516-921-8666