

# Sur-Gard MLR2000

## Virtual Network Receiver



## Installation Manual

---

**WARNING:** This manual contains information on limitations regarding product use and function and information on the limitations as to liability of the manufacturer. The entire manual should be carefully read.

version 1.4

## FCC Compliance Statement

**CAUTION:** Changes or modifications not expressly approved by Digital Security Controls Ltd. could void your authority to use this equipment.

This equipment has been tested and found to comply with the limits for a Class B digital device, pursuant to Part 15 of the FCC Rules. These limits are designed to provide reasonable protection against harmful interference in a residential installation. This equipment generates, uses and can radiate radio frequency energy and, if not installed and used in accordance with the instructions, may cause harmful interference to radio communications. However, there is no guarantee that interference will not occur in a particular installation. If this equipment does cause harmful interference to radio or television reception, which can be determined by turning the equipment off and on, the user is encouraged to try to correct the interference by one or more of the following measures:

Re-orient the receiving antenna.

Increase the separation between the equipment and receiver.

Connect the equipment into an outlet on a circuit different from that to which the receiver is connected.

Consult the dealer or an experienced radio/television technician for help.

The user may find the following booklet prepared by the FCC useful: "How to Identify and Resolve Radio/Television Interference Problems". This booklet is available from the U.S. Government Printing Office, Washington D.C. 20402, Stock # 004-000-00345-4.

### IMPORTANT INFORMATION

This equipment complies with Part 68 of the FCC Rules. On the side of this equipment is a label that contains, among other information, the FCC registration number and ringer equivalence number (REN) for this equipment. If requested, this number must be provided to the Telephone Company.

FCC Registration Number: 1VDCAN-25404-AL-N

REN: 0.2B

USOC Jack: RJ11C

### Telephone Connection Requirements

A plug and jack used to connect this equipment to the premises wiring and telephone network must comply with the applicable FCC Part 68 rules and requirements adopted by the ACTA. A compliant telephone cord and modular plug is provided with this product. It is designed to be connected to a compatible modular jack that is also compliant. See installation instructions for details.

**Ringer Equivalence Number (REN)** The REN is used to determine the number of devices that may be connected to a telephone line. Excessive RENs on a telephone line may result in the devices not ringing in response to an incoming call. In most but not all areas, the sum of RENs should not exceed five (5.0). To be certain of the number of devices that may be connected to a line, as determined by the total RENs, contact the local Telephone Company. For products approved after July 23, 2001, the REN for this product is part of the product identifier that has the format

US: AAAEQ##TXXXX. The digits represented by ## are the REN without a decimal point (e.g., 03 is a

REN of 0.3). For earlier products, the REN is separately shown on the label.

**Incidence of Harm** If this equipment Sur-Gard MLR2000 causes harm to the telephone network, the telephone company will notify you in advance that temporary discontinuance of service may be required. But if advance notice is not practical, the Telephone Company will notify the customer as soon as possible. Also, you will be advised of your right to file a complaint with the FCC if you believe it is necessary.

**Changes in Telephone Company Equipment or Facilities** The Telephone Company may make changes in its facilities, equipment, operations or procedures that could affect the operation of the equipment. If this happens the Telephone Company will provide advance notice in order for you to make necessary modifications to maintain uninterrupted service.

**Equipment Maintenance Facility** If trouble is experienced with this equipment Sur-Gard MLR2000, for repair or warranty information, please contact the facility indicated below. If the equipment is causing harm to the telephone network, the Telephone Company may request that you disconnect the equipment until the problem is solved. This equipment is of a type that is not intended to be repaired by the end user. Simplex Time Recorder Co. 100 Simplex Drive, Westminster MA 01441-0001 USA, Tel: (978) 731-2500

**Additional Information** Connection to party line service is subject to state tariffs. Contact the state public utility commission, public service commission or corporation commission for information. If your home has specially wired alarm equipment connected to the telephone line, ensure the installation of this equipment Sur-Gard MLR2000 does not disable your alarm equipment. If you have questions about what will disable alarm equipment, consult your telephone company or a qualified installer.

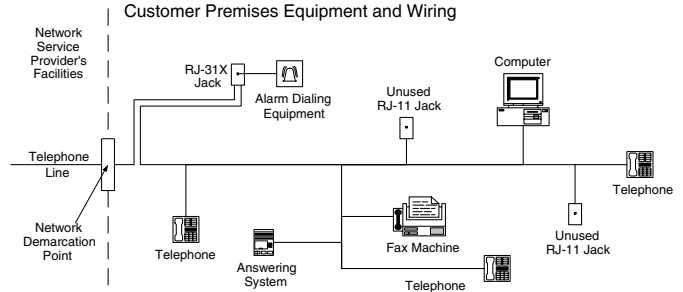

## Industry Canada Statement

IC: 160A-MLR2000

**NOTICE:** This equipment meets the applicable Industry Canada Terminal Equipment Technical Specifications. This is confirmed by the registration number. The abbreviation, IC, before the registration number signifies that registration was performed based on a Declaration of Conformity indicating that Industry Canada technical specifications were met. It does not imply that Industry Canada approved the equipment.

**NOTICE:** The Ringer Equivalence Number (REN) for this terminal is 01. The REN assigned to each terminal equipment provides an indication of the maximum number of terminals allowed to be connected to a telephone interface. The termination on an interface may consist of any combination of devices subject only to the requirement that the sum of the Ringer Equivalence Numbers of all the devices does not exceed five.

## Table of Contents

<b>Section 1 - Introduction .....</b>	<b>1</b>	7.4 Ademco Contact ID .....	23
1.1 CPM2000 .....	1	7.5 Ademco Express .....	25
1.2 DRL2000 .....	1	7.6 Ademco Super Fast (High Speed Format) .....	25
1.3 Power and Supervision .....	1	7.7 FBI Super Fast Format .....	25
1.4 CPM2000 Outputs/ Inputs .....	1	7.8 ITI Format .....	25
1.5 System Overview .....	2	7.9 ITI Sensor Library .....	25
1.6 Virtual Receiver Architecture .....	2	7.10 Modem II, Modem IIE, Modem IIIa <sup>2</sup> and BFSK Formats .....	26
1.7 Number of Line Cards Supported .....	2	7.11 SIA FSK .....	26
1.8 Redundancy .....	2	7.12 Silent Knight FSK1, FSK2 .....	26
1.9 Approvals .....	2	7.13 Silent Knight FSK2 Protocol .....	26
1.10 Virtual Connectivity .....	2	7.14 Sescoa Super Speed .....	27
1.11 Internal 10B2 Ethernet .....	2	7.15 DRL2000 Predefined Library Decoding and Event Codes Table27 .....	27
<b>Section 2 - Quick Start .....</b>	<b>3</b>	<b>Section 8 - CPM2000 Central Processing Module... 29</b>	
2.1 Receiver Setup and Operation .....	3	8.1 General Information .....	29
2.2 Bench Testing .....	9	8.2 Features .....	29
<b>Section 3 - Installation .....</b>	<b>10</b>	8.3 CPM2000 Controls .....	29
3.1 Dimensions .....	10	<b>Section 9 - CPM2000 Wiring Diagram .....</b>	<b>30</b>
3.2 Definity DNIS .....	10	9.1 Loss of Socket/Automation .....	30
3.3 Mounting the Receiver .....	10	9.2 CPM Redundancy .....	30
3.4 Printer Connections .....	10	9.3 CPM Restoral .....	30
3.5 Computer Connections .....	10	<b>Section 10 - MLR2000 Computer Interface .....</b>	<b>31</b>
3.6 Telephone Line Connections .....	10	10.1 Virtual connectivity .....	31
3.7 Grounding .....	10	10.2 Automation Mode .....	31
3.8 Power Supply .....	10	10.3 TCP/IP Ports .....	31
3.9 Battery Charging Current .....	10	10.4 Client Side Connects .....	31
3.10 Removing and Installing System Components .....	10	10.5 Stream Packet Structure .....	31
3.11 To Install a Line Card Module .....	10	10.6 Status Addressing .....	31
<b>Section 4 - DRL2000 Digital Receiver Line Card ....</b>	<b>11</b>	10.7 Overview of Communication .....	31
4.1 General Information .....	11	10.8 Console specifies which SG Automation to Supervise .....	32
4.2 DRL2000 Features .....	11	<b>Section 11 - PSU2000 Power supply Module .....</b>	<b>35</b>
4.3 Installation .....	11	<b>Section 12 - Automation Protocols .....</b>	<b>36</b>
4.4 DRL2000 Controls .....	11	12.1 Data Byte protocol .....	36
<b>Section 5 - DRL2000 Operating Mode .....</b>	<b>12</b>	12.2 Acknowledgment of the Signal .....	36
5.1 DRL2000 Standby Mode .....	12	<b>Section 13 - Detailed Description of Computers ...</b>	<b>37</b>
5.2 DRL2000 Cold Start-up .....	12	13.1 COM Responses .....	37
5.3 Communications in Progress .....	12	13.2 Automation Absent .....	37
<b>Section 6 - Profiles .....</b>	<b>13</b>	<b>Appendix A - DRL2000 Communication Formats .....</b>	<b>38</b>
6.1 Introduction .....	13	<b>Appendix B - Decimal - HEX - Binary Conversion Chart.</b>	<b>39</b>
6.2 A.H.S. (Automatic Handshake Selection) .....	14	<b>Appendix C - ASCII Character Chart .....</b>	<b>40</b>
6.3 Static Options: [00] - [2F] .....	14	<b>Appendix D - Printer Words: Options [60-6F] .....</b>	<b>41</b>
6.4 Dynamic Options: [30] - [FF] .....	16	<b>Appendix E - Panels Compatibility List .....</b>	<b>43</b>
<b>Section 7 - DRL2000 Communication Formats .....</b>	<b>23</b>		
7.1 Common Formats .....	23		
7.2 Sur-Gard DTMF Formats .....	23		
7.3 Acron Format .....	23		

**NOTE:**

## Section 1 - Introduction

The MLR2000 is a Multi-Line, Multi-Format Digital Receiver for commercial fire and burglary. The basic unit consists of 60 individual line-cards (DRL2000) connected to a dual redundant central resource, router and protocol converter (CPM2000). The MLR2000 includes many features, especially high bandwidth internal buses and high bandwidth external connections to allow traditional network philosophies to be observed for the first time on a central station receiver. The MLR2000 can decode a variety of popular and widely used communication formats. Refer to Appendix A, DRL2000 Communication Formats for a list of the available communication protocols.

The MLR2000's real-time clock and calendar 'stamps' all information received with the time and date, and all information may be printed or forwarded to a computer. To ensure security, adjustment of the clock, calendar and other programming is protected by password codes.

### 1.1 CPM2000

The CPM2000 Central Processing Module oversees operation of the receivers. Along with its built-in keypad and LCD message screen, the CPM2000 features TCP/IP, two parallel printers, one serial printer and two serial computer interface capability.

### 1.2 DRL2000

Each DRL2000 module can monitor two telephone lines. The line card module is equipped with a 256-event non-volatile memory buffer to record events and corresponding telephone numbers. Caller Source capability is built-in and telephone numbers can be printed out, sent to automation and stored in memory. Events and information stored in memory can be printed at any time. Each line card also features flash EPROM uploads through the Debug port for software upgrades or options programming.

### 1.3 Power and Supervision

#### 1.3.1 Power

The MLR2000 power supplies inputs are 120 Vac at 10A, 60 Hz. Each AC power supply supplies a nominal 28 Vdc +/-5% power. The receiver is equipped with 24V rechargeable stand-by battery connections at 160 Ahr. and an automatic battery charger. Provision is made for an internal battery pack for temporary use. User supplied batteries may be used externally but must be fused and connected to 10-32 lugs supplied via a stud termination. Full power operation is .5 Amps per line and 1 Amp per CPM at 28 Vdc nominal. All elements have extensive power down capabilities and are implemented in CMOS logic.

#### 1.3.2 Supervision

The stand-by battery voltage and connections are supervised. The Line Cards are also continuously supervised to ensure uninterrupted communication with the CPM2000. Any trouble conditions are reported on the LCD screens and sent to the printer and the computer.

The DRL2000 Line Card Module also verifies communications with the CPM2000. In the event of a malfunction, the operator will be advised with a visual indication and the Line Cards will continue to function. Each line card will continue to receive information.

The printer is supervised for off-line, paper out and other trouble conditions. The communication link to the computer through the RS232 ports is monitored by the supervisory 'heartbeat' test transmissions.

#### 1.3.3 Compatibility

Central station automation software packages such as:

- MAS • DICE • SIMS II • GENESYS • S.I.S. • IBS • MicroKey

support the MLR2000 Sur-Gard interface.

Refer to automation software specifications for compatibility.

**NOTES:** Automation connections are considered supplementary per UL864 Listing. Compatibility with the automation software in a system used at a central station is intended to be handled under a separate UL1981 software and/or site certification evaluation.

### 1.4 CPM2000 Outputs/ Inputs

- The CPM2000 features four switched-negative (PGMOUT1 is activated when automation fails) outputs, two relay outputs and four inputs.

### 1.5 System Overview

- Patented Caller Identification (Call Display) capability
- Patent Pending DNIS Identification
- nonvolatile RAM on each DRL2000 line card module for programming and event buffer.
- Fast Ethernet communication between line-cards and CPM
- Flash download for software upgrades
- Up to 64 different options set (profiles per line)
- Patented virtual configurations
- 3/1, 4/2 formats with or without parity, 4/1 without parity at 10, 14, 20, or 40 baud
- 4/1, 4/2, 4/3, and 4/3 DTMF formats
- Optional\* formats: 3-2, 4/1, 4/2 extended
- ACRON DTMF format
- Contact ID (DTMF) format
- Adcor 20 baud
- Super fast or high speed DTMF format, with or without parity
- DTMF 4/1 express format (optional)
- DTMF 4/2 express format
- FBI super fast format with or without parity
- Radionics Modem II, Modem IIE, Modem IIIa2 and BFSK formats
- SIA format: 110 and 300 baud, tone and data acknowledgement
- SK FSK0, FSK1, FSK2
- Any handshake frequencies by increment of 100 Hz from 100 Hz to 2300 HZ, Dual Tone, SIA FSK, Modem II and ITI selected by configuration commands
- Up to 8 different handshakes per profile.
- Large, easy to read 2-line, 16-characters-per-line, LCD (Liquid Crystal Display) screen
- All modules function individually to help ensure uninterrupted operation during hardware or software upgrades
- Inputs on CPM2000 for UPS supervisory
- 255 lines maximum per receiver
- 256-event memory buffer on each individual line card
- Real-time clock
- CPM2000 features 32-bit micro-controller
- Two parallel printer port; three serial RS232 ports and one 10 BaseT connection.
- Programmable serial ports configuration
- Programmable System Functions: Computer and printer
- Fast transmission of multiple alarms to the computer and printer to ensure operator's quick response

\*All formats noted as optional are selected using configuration commands.

- Continuous verification of the computer-receiver links with the 'heartbeat' function
- Switched-negative outputs on CPM2000 (special applications)
- AC-lost detection and stand-by battery supervision
- Low battery detection and automatic low battery disconnect to prevent deep-discharge damage to battery
- Operator Acknowledge
- Telephone Line Supervision

## 1.6 Virtual Receiver Architecture

The most novel feature of the DRL2000 is the ability to use Telco information delivered as a DNIS (dialed number identification service) to allow the Sur-Gard expert format identification system to option on the fly each received call to eliminate dedicated line pool hardware. Instead the DNIS allows call up options which set up virtual line pools to identify security formats and extend account numbers. Standard dialed number identification is supported up to 10 digits.

Each dialed number should be assigned to a virtual receiver. Each dialed number would have formerly been a line pool on conventional line-cards.

## 1.7 Number of Line Cards Supported

The system will support a maximum of 255 line-cards concurrently connected. Optional hubs will be required for backplane connectivity in installations beyond 5 shelves.

## 1.8 Redundancy

The MLR2000 has a main power supply module for side A and for side B, and an optional stand-by power supply per rack. Additional 10B2 Ethernet is available as a backup B side. This and the ability to mount an optional second CPM2000 controller will allow for seamless system redundancy in maximum configuration. In practical terms this means that any line card may fail and not affect system performance ; and with redundant CPM's the B unit will take up where the A unit failed with a loss of no more than 30 seconds. External networking components would necessarily be duplicated to take full advantage of this configuration.

## 1.9 Approvals

### 1.9.1 Industry Approvals

The MLR2000 in redundant configuration is listed under the following UL standards:

- UL 864 Control Units for Fire-Protective Signaling Systems
- UL 1610 Central Station Burglar Alarm Units

**This equipment should be installed in accordance with the requirements of NFPA72, NFPA70 and UL827.**

### 1.9.2 System Connectivity

The system may have two identical CPMs both connected to internal resources. Internal connections are A and B side 28 V power and A and B side 10B2 Ethernet. Additional internal connections are power monitoring services on the primary rack. External connections are two parallel

printer and three serial ports. The serial ports are intended primarily for debug applications but may be used for fall-back automation outputs (optional). The primary automation connection is via 10BT Ethernet connection. Again if redundant CPM's are used the external network components must be duplicated to allow for full redundancy.

### 1.9.3 Automation Mode

In automation mode it is expected that the primary connection is via TCP/IP networking on the 10BT Ethernet connection. A menu on the CPM2000 will prompt the user for the IP address setup and port setup. Once the configuration management port is set up, all other options and setups may be done via a Telnet session or the Sur-Gard Console.

### 1.9.4 UL Manual Mode

For UL manual mode, each event will activate the internal buzzer to be acknowledged manually. Each event will be sent automatically to all connected printers.

**NOTE: For central station applications the signaling performance of each dact shall be manually tracked. Failure to receive a signal from a dact over a 24-hour period shall be handled as a trouble signal.**

## 1.10 Virtual Connectivity

Each receiver has one IP address and a number of associated ports. Internal socket programming uses specific ports for expected tasks. The MLR2000 is the listener.

### 1.10.1 Configuration Management - Sur-Gard Configuration Port 1024

A tool is provided for NT 4 + or Windows 9x/2000/XP environments which provides graphical style menu for configuration management. Additional features are storage of virtual receiver setups, formats conversion table and configuration wizards.

### 1.10.2 Status Addressing

Line card status will be reported via physical addressing. This will be assigned by shelf and slot number. All device status information is in Sur-Gard format. The reporting of status on this port, automation output and printer will relate to physical addressing.

### 1.10.3 Automation input/output (Port 1025, 1026)

Traditional automation communication will be provided via a minimum of two ports. The primary port is Sur-Gard standard output and provides Sur-Gard standard automation output.

Optional secondary automation communication will be provided to map to proprietary types. It is expected that named virtual receiver types will be mapped to this output. In addition two way automation commands may be supported on this port.

## 1.11 Internal 10B2 Ethernet

Internal Ethernet is not standard TCP/IP instead it has allocated proprietary type per Internet standards. Full physical 10B2 requirements are met allowing approved segment interconnects to be used including hubs, optical transceivers and wan interconnects (wan interconnects preclude trap and capture commands).

## Section 2 - Quick Start

### 2.1 Receiver Setup and Operation

#### 2.1.1 Unpacking

Carefully unpack the receiver and inspect for shipping damage. If there is any apparent damage, notify the carrier immediately.

#### 2.1.2 Ethernet Connections

**NOTES:** Be sure to be properly grounded.

- Take a 50 ohm coaxial cable and connect one end to the BNC connector (ETHERNET A) of the CPM2000. The other end of the coaxial cable should be connected to the BNC connector (ENET A IN) of the backplane.

- Take a 50-ohm coaxial cable and connect one end to the BNC connector (ETHERNET B) of the CPM2000. The other end of the coaxial cable should be connected to the BNC connector (ENET B IN) of the backplane.
- Make sure that there are 50 ohm BNC terminators on the other end of the T Connectors of the CPM2000 labelled ETHERNET A AND B.
- Make sure that there are 50 ohm BNC terminators connected on the BNC terminals marked ENET A OUT and ENET B OUT of the backplane. (This should be already done.)

Figure 1, 60 Line Cards Configuration

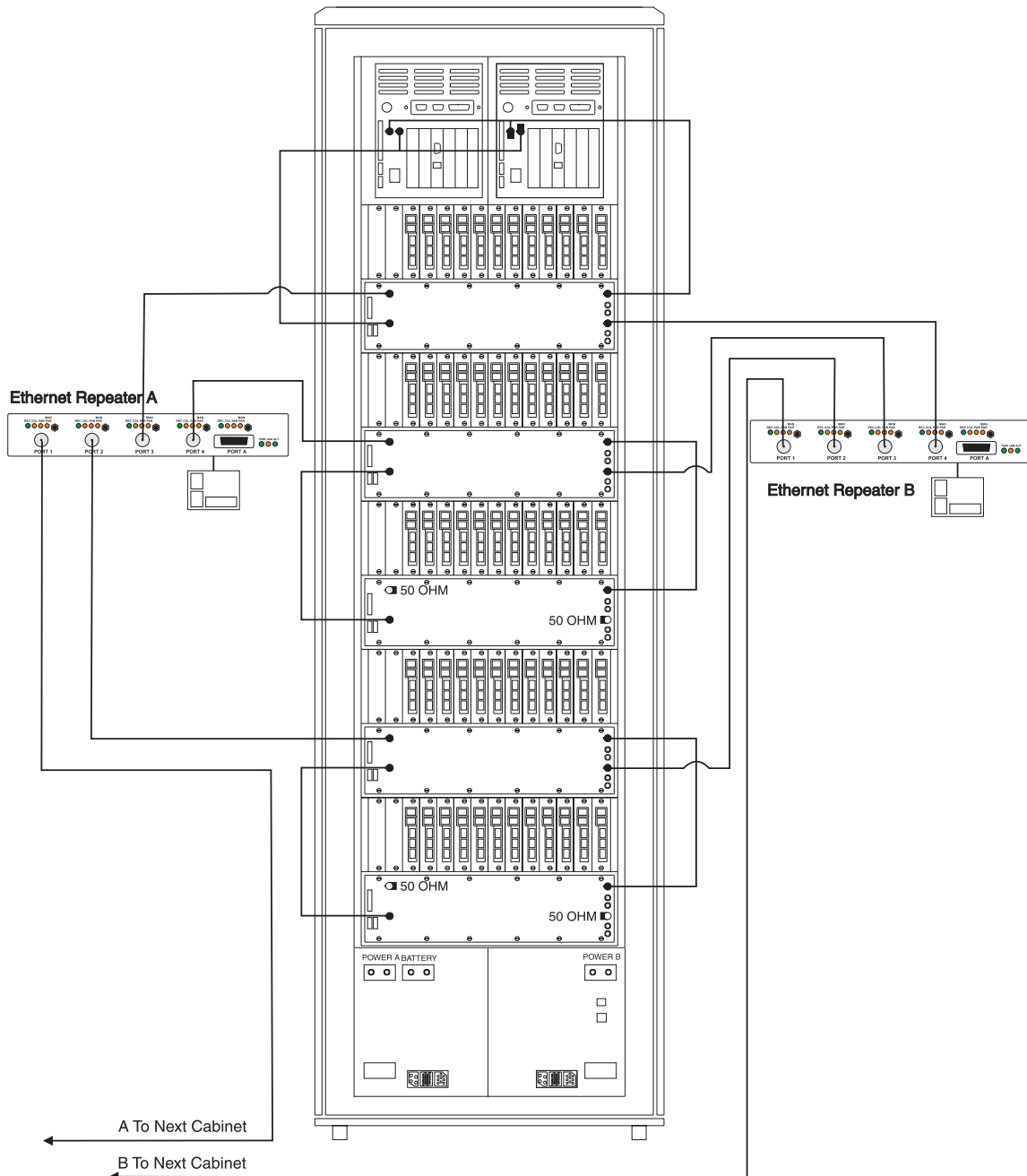
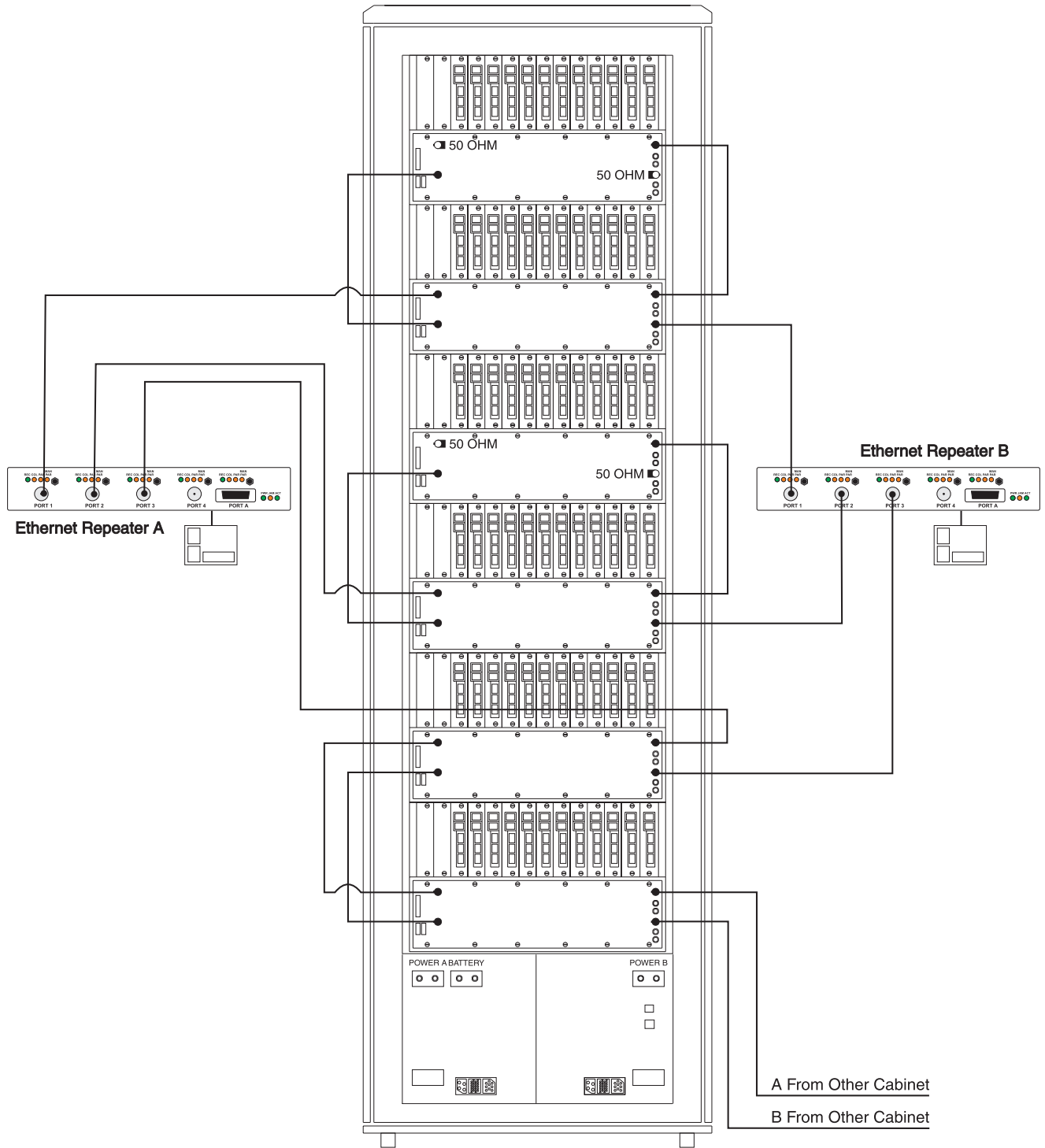

Figure 2, 72 Line Cards Configuration (Expansion cabinet)



### 2.1.3 Power Cable Connections

- Take the power cable for the CPM2000 and connect the labelled wire to the designated terminal on the backplane. Take the other end of the power cable and connect it to the power connector on the CPM2000.

- Take the power cables (10 gage) and connect one end to the power terminals of the backplane marked PWR-GND (black cable) and +28 VDC A (red cable). Take the other end of the power cables and connect to a 28 VDC power supply (make sure power is OFF).

Figure 3, 60 Line Cards Configuration

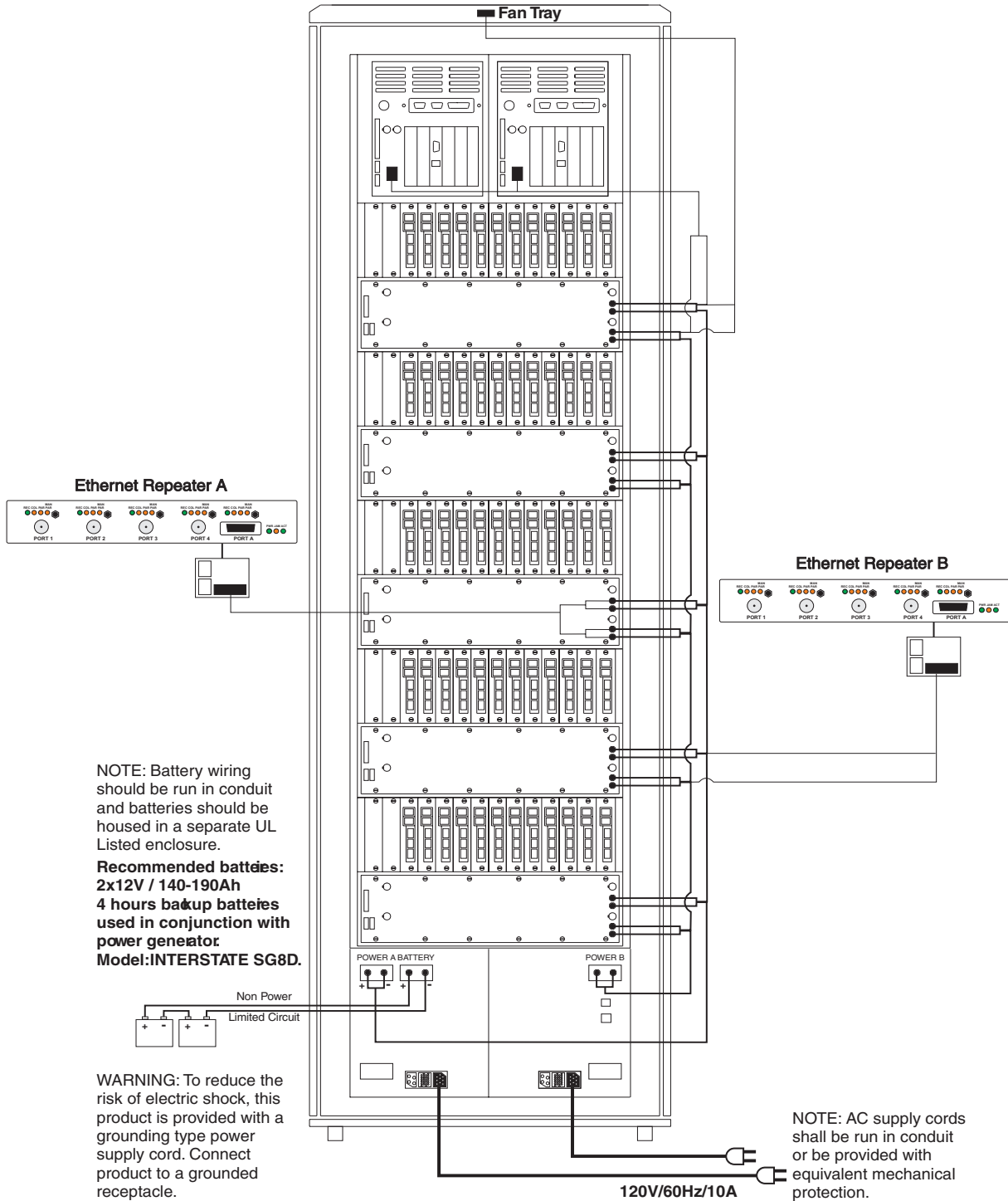
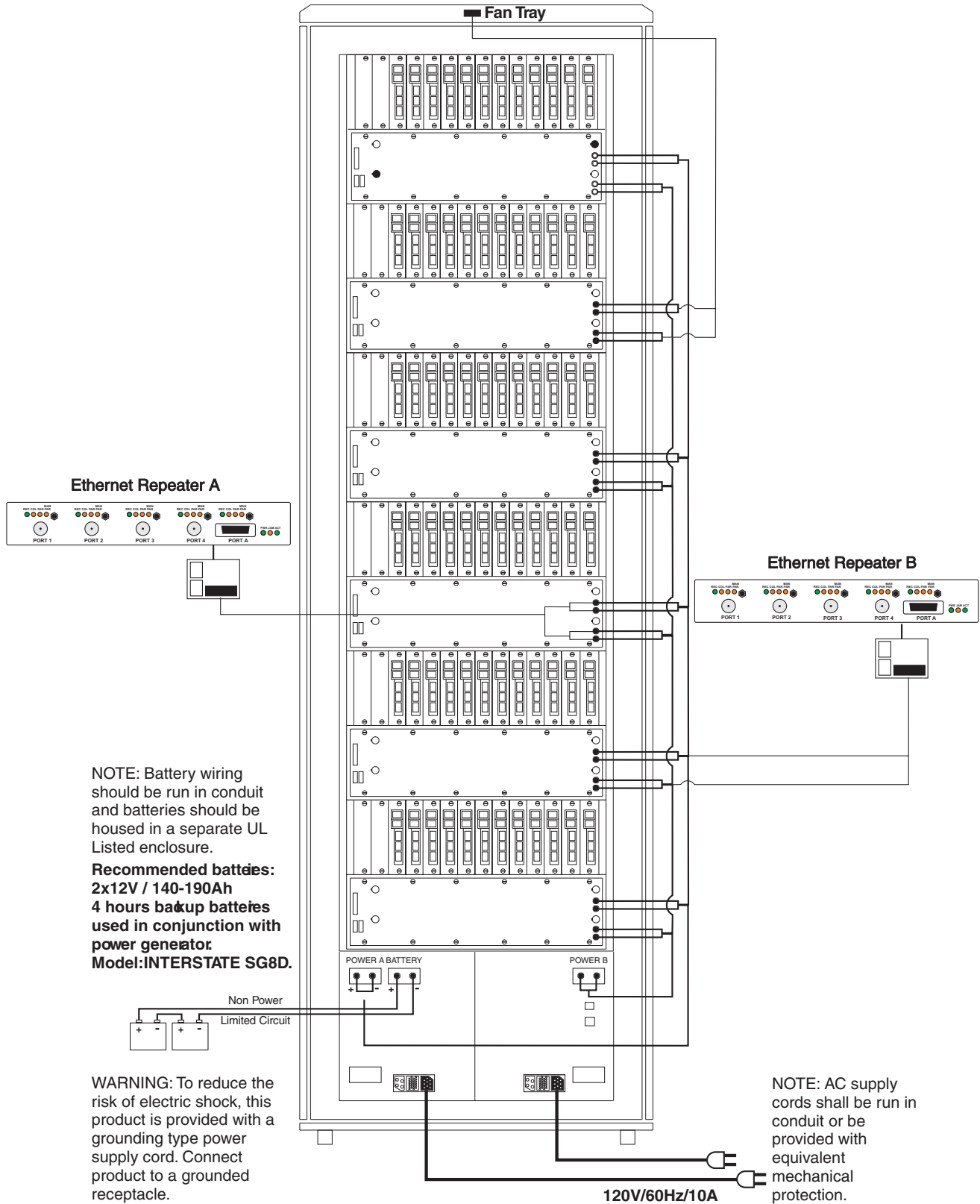

Figure 4, 72 Line Cards Configuration (Expansion Cabinet)



## 2.1.4 Signaling/Supervisory Connections

Figure 5, 60 Line Cards Configuration

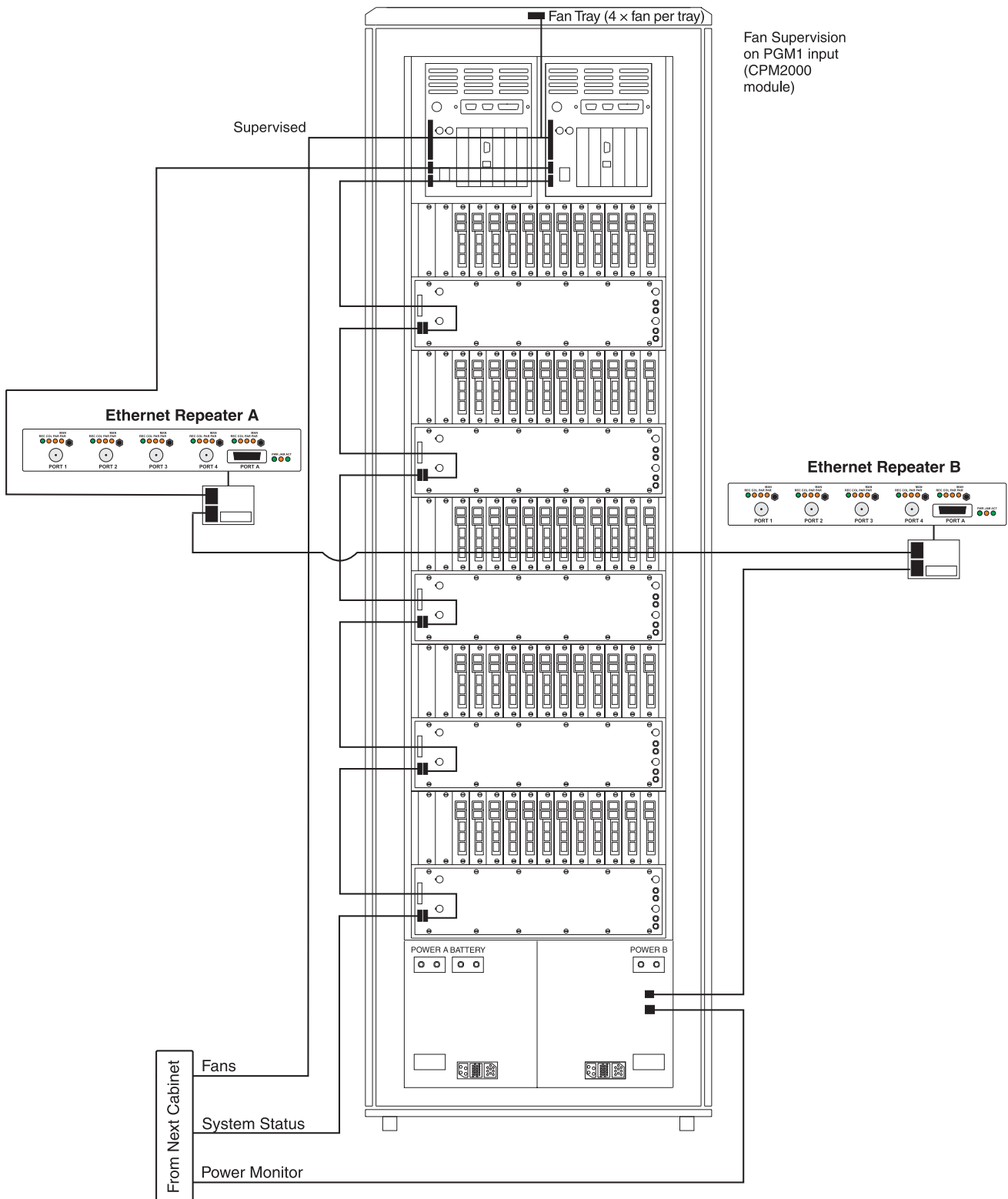
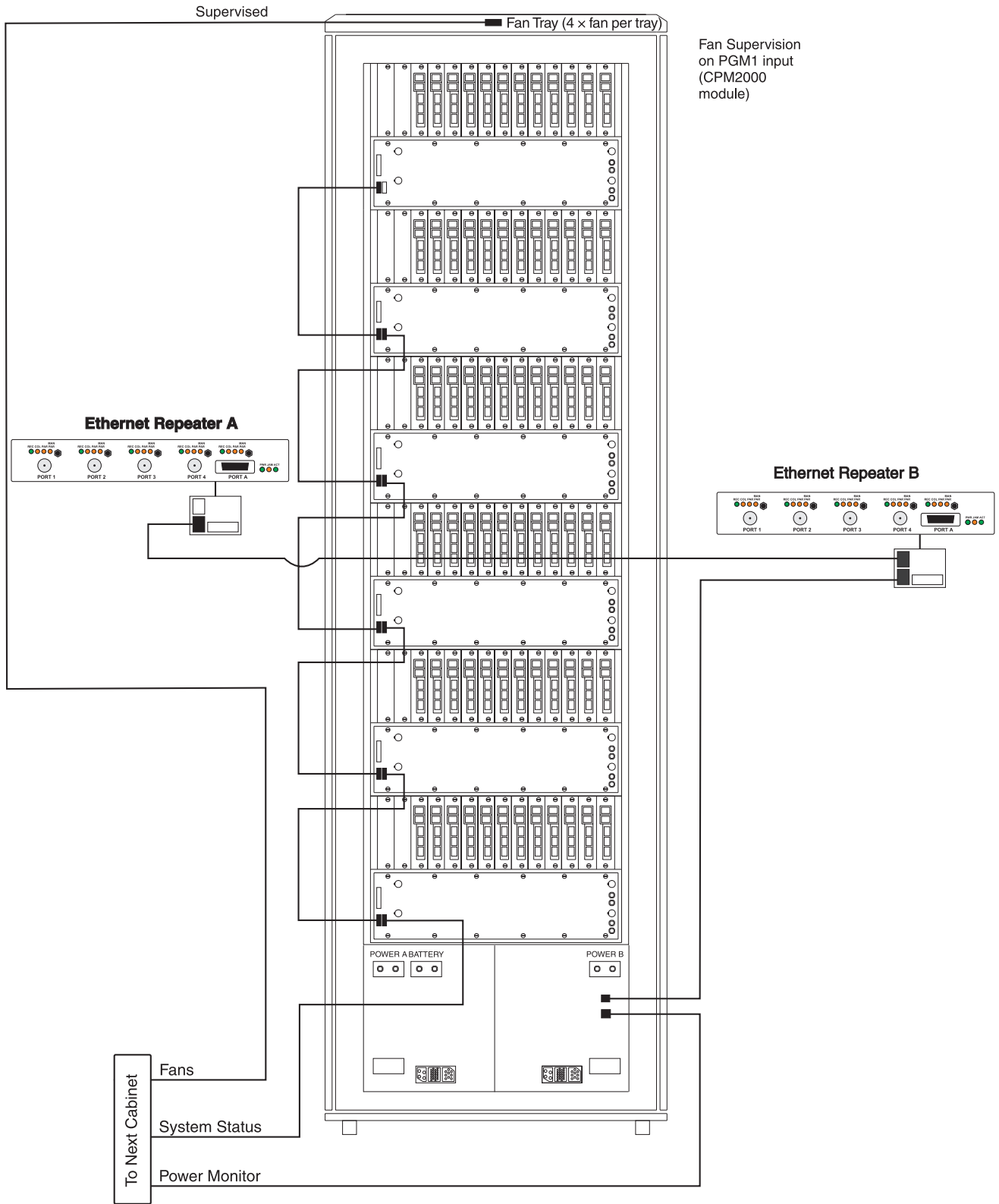

Figure 6, 72 Line Cards Configuration (Expansion Cabinet)



## 2.2 Bench Testing

It is suggested that the receiver be tested before actual installation; becoming familiar with the connections and setup of the unit on the work bench will make final installation more straightforward.

The following items are required:

- 28 VDC Power supply
- One telephone line
- One or more dialer or digital dialer control panels

### 2.2.1 Power Up

When the 28 VDC power is applied, the CPM2000 unit will beep for approximately 1-2 minutes during system initialization. The buzzer will deactivate as soon as the CPM2000 software initializes and is running. The LCD display on the CPM2000 should display 'Primary'. If the Line Cards do not have telephone lines connected, the DRL2000 modules will activate 'Line Fault' lights. The telephone line should be connected to the POTS jack at the back of the DRL SUBRACK. As soon as the line card detects a phone line, a line restore message will be sent to the printer and computer output. If the phone line is removed, a line fault message will be sent to the printer and computer output.

If there is no computer or printer connected, a trouble message will be displayed on the CPM2000 LCD and the 'ACK' light will flash. Press the [ACK] button to silence the CPM2000 buzzer.

The watchdog LED on the line card should flicker as soon as it is initialized. The Trouble LED will activate if the line card is not receiving a poll from the CPM2000. As soon as the line card responds to the polling, the Trouble LED should deactivate.

### 2.2.2 Operation with Default Programming

Without any changes to the factory default programming, the receiver operates as follows:

- Answers incoming calls on the first ring
- Sends 2300 Hz as the first handshake
- Sends 1400 Hz as the second handshake
- Sends dual tone as the third handshake
- Sends SIA FSK tone as the fourth handshake
- Sends ITI , Modem IIE/ IIIa<sup>2</sup> tone as fifth handshake
- Sends Modem II tone as sixth handshake
- Receives all communication formats, except for: 3/2, 4/1 express, 4/2 extended and 4/2 checksum.
- The above formats can be manually selected.
- Signals can be displayed on the debug output computer as they are received. The signals are then sent to the parallel printer and computer connected to serial port COM1 or to the 10BT connector. The default event codes described in the 'DRL2000 Library Decoding and Event Codes Table' will be used with the Sur-Gard automation communication protocol to send signals to the computer, if connected.
- If a computer is not connected, press the [ACK] button on the CPM2000 module to silence the buzzer.

### 2.2.3 Debug Output

The debug output is another means of accessing the line-card's programmed options and diagnostics features. A debug cable is required to connect by serial communication from the line card to a standard PC running Windows 9x/2000/XP.

### 2.2.4 Debug Cable Connectivity

- Connect the RJ45 end of the debug cable to the debug jack on the front of the line card or to the debug jack of the paddle board on the back of the sub-rack.
- Connect the female DB-9 connector to the serial port of a computer (COM1 port - usually DB-9 male, COM2 port - DB-25 female).

### 2.2.5 Debug Software Setup

- Using WIN95, point and click on the 'START' button. Access 'Programs' -> 'Accessories' -> 'HyperTerminal'. Once in the HyperTerminal window, point and click on 'Hypertrm.exe' icon.
- A connection description window should appear. A prompt should appear on the 'Name' category. Type a name. Point and click on the 'OK' button.
- A phone number window should appear. Choose the direct to COM port required for connection and point and click on 'OK'.
- COMX properties windows should appear. The configuration should be:
  - Bits per second: 19200
  - Data bits: 8
  - Parity: None
  - Stop bits: 1
  - Flow control: None
- Point and click on the 'OK' button after setting the configuration.
- The HyperTerminal window should appear. Press any button. The debug menu will be displayed.

### 2.2.6 Button Commands

- A:**This button will display the address of the line card. The address includes the shelf and slot number of the line card making each line card unique.
- D:**This button will initiate the download of a file to the line card.
- O:**This button will enable the user to dump the current programmed options of the line card or set an option to a particular value.
- P:**Sets the message priority to be displayed. This is useful for debugging purposes only.

### 2.2.7 Downloading steps

1. Press the 'D' button to initiate downloading of the binary file. The Hyper Terminal will display:  
Ready to download.  
CCCC
2. Point and click at 'Transfer' on the Hyper Terminal menu and access the 'Send File' category. The 'Send File' window should appear.
3. Change the protocol to 'X-modem' and place the correct path and file name of the binary file to be downloaded.
4. Point and click on the [Send] button and the downloading status window should appear.

The line card will restart automatically after a successful download.

### 2.2.8 Printer output

Printer Examples:

	Date	Time	SS/00	Receiver Type	Receiver #	Line #	Account #	Alarm Code	Message
Ex.	JUN 01 2000	- 08:00:22	- 01/02	-SG	- 01	- 061	- 965	- E9	RESTORE
Ex.	JUN 01 2000	- 08:00:22	- 01/02	-SG	- 01	- 061	- 965	- F9	TROUBLE
Ex.	JUN 01 2000	- 08:00:22	- 01/02	-SG	- 01	- 061	- 965	- 2	PANIC ALARM

## Section 3 - Installation

### 3.1 Dimensions

The MLR2000 is implemented into a 42U \* 600 mm \* 800 mm cabinet. The cabinet has 7 subracks, each on is 19 inches \* 6U high. Housed in the top subrack, the CPM2000 comes complete with its own 19 inch \* 6U tray. Below the CPM2000 tray, the MLRX-2000 expansion cage provides for up to 12 DRL2000 line cards. Each DRL2000 line card is 6U \* 6HP \* 220 mm. Each paddle board is 3U \* 6 HP \* 220 mm. The PSU-2000 comes complete in its own 19 inch \* 6U high cage.

The main MLR2000 cabinet will hold 2xCPM2000, 5xMRLX-2000, 60xDRL2000, 2xPSU-2000.

The expansion MLR2000 cabinet will hold 6xMRLX-2000, 72xDRL2000, 2xPSU-2000.

#### 3.1.1 Spacing

All units of a receiver must be within 50 ft. (cable length) of the CPM to provide system timing integrity.

### 3.2 Definity DNIS

The AT&T Definity G3 DTMF vdn codes have been tested and are supported by the MLR2000.

### 3.3 Mounting the Receiver

Install the MLR2000 in a closed 19" rack or cabinet with a locking rear access door. Cover all unused spaces with blank metal plates. The LCD screen on the receiver is designed to be viewed below eye level. A Stand-up Unit (61.25" tall up to 60 telephone lines, part #90000016) can be supplied for a complete installation.

**NOTE:** If 60 telephone lines are not used, cover each unused location with a blank plate.

### 3.4 Printer Connections

The following UL Listed printers can be used with the MLR2000: Sur-Gard CPU-1150 (Panasonic KX-P1150)

DMP SCS-PTR (Okidata Microline 182/184)

Connect the parallel printers to the MLR2000 printer output ports using parallel printer cables.

**NOTE:** A minimum of two printers are required for UL Listed applications.

Do not use a printer cable which has only 1 common ground wire.

### 3.5 Computer Connections

Connect the computer to the MLR2000 RS232 port using a serial cable to COM1.

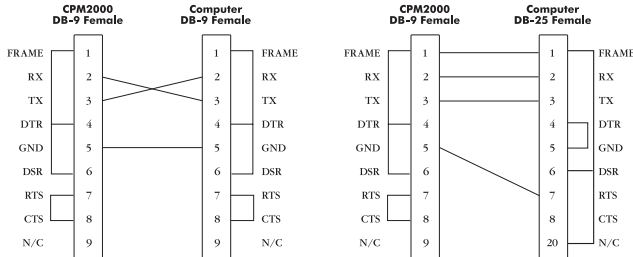

**NOTE:** Pins 1, 4 and 6 on the receiver side are connected together. Pin 7 and 8 are also shorted together. Pin 9 is not connected.

### 3.6 Telephone Line Connections

Each paddle module has the connections shown here. Connect each line module output (POTS) to the telephone line (analog) with 6-pin modular cables.

**NOTE:** Use minimum AWG 26 wires for telephone cables.

**\*NOTE:** Connection of an Ademco radio receiver model 7810RT or 7830R can be done on the serial port of the paddle module. The device should be mounted in the same room as the MLR2000 receiver (within 20 ft.). The connection shall be run in conduit or equivalent i.e. providing mechanical protection.

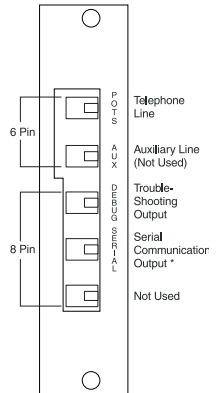

### 3.7 Grounding

For maximum resistance to static and electrical noise, the 19" rack frame must be connected to earth ground through the AC utility box.

### 3.8 Power Supply

Ensure that all electrical connections are made correctly. After verifying all connections, connect the RED and BLACK leads to a 24 (2 x 12V batteries in series) VDC sealed rechargeable battery. Be sure to observe polarity when connecting the battery. When the battery is connected, test the system under battery power only.

**CAUTION:** Connecting a positive (+) terminal to a negative (-) terminal may cause a fire and possibly serious personal harm.

### 3.9 Battery Charging Current

The maximum battery charging current is factory set at 5A.

### 3.10 Removing and Installing System Components

#### To remove the Power Supply Modules

The Power Supply charges the battery and provides low battery voltage disconnect; removing the power supply module will disconnect the battery and shut down the entire system. Please make sure there is a second power supply module installed.

#### To Remove the CPM2000 Module

Slowly pull the module out of the metal cabinet.

#### To Remove a Line Card Module

Slowly pull the module out of the sub rack.

### 3.11 To Install a Line Card Module

Slowly insert the module in the sub rack.

#### Installation Checklist (Complete Operation)

- 19" Rack Mount Cabinet connected to earth ground
- SG-PSU2000 Power Supply installed
- 6-pin modular cable(s) connected to DRL2000 and telephone line
- Parallel Printer Cable connected to MLR2000 Parallel Printer Port
- Parallel Printer power connected
- Computer connected to MLR2000 COM1 port using serial cable
- Computer connected to MLR2000 10BT port using 10BT cable

## Section 4 - DRL2000 Digital Receiver Line Card

The DRL2000 acts as an interface between the digital alarm transmitter and the CPM2000. Different communication formats can be used to transmit the information.

The main functions of the line-cards are to continuously monitor the telephone line, receive calls from digital dialers or control panels, and to report alarms to the CPM2000. In addition, if a Line Card is unable to communicate with the CPM2000, then each Line Card is capable of functioning independently. Each Line Card can record 256 different alarm messages and 256 Caller-ID telephone numbers.

### 4.1 General Information

The receiver is capable of processing signals from digital communicators in variety of formats. The type of signal (alarm, trouble, restore, cancel and so on) can be printed.

### 4.2 DRL2000 Features

- Operator selection of communication formats and handshake priority
- 64 profiles per line card, up to 255 line pools.
- On-Board Ethernet interface.
- Flash Download for software upgrades.
- Records up to 256 messages.
- Records up to 256 Caller-ID phone numbers. This feature helps locate and identify the source of the device in communication and assists in troubleshooting
- Multiple alarms are forwarded to the computer and printer through the CPM2000 with minimum delay
- The DRL2000 monitors the telephone line connection, and line faults will result in reports to the computer and the printer
- DRL2000 automatically goes into stand-alone mode in case of CPM2000 failure
- 'Watchdog' timer continually monitors receiver operation
- 'Cold boot' option allows receiver's configuration to be reset to factory default programming
- DSP processing to reduce data receiving errors, and to help for weak and noisy signals
- Gain boost available to amplify weak signals
- Serial link for troubleshooting

### 4.3 Installation

It is recommended that a DRL2000 Cold Start-up be performed when the unit is updated with a new program version. Refer to Operating Mode Section (DRL2000 Cold Start-up for information.

After the cold start-up, check the configuration information listed in the Quick Reference Guide to make any required changes for your particular application.

### 4.4 DRL2000 Controls

Each DRL2000 Module has one telephone line.

Momentarily depressing and releasing a button will register as a single input or keystroke.



**ON LINE:** The 'on-line' light will be ON when the Line Card is on-line in communication. The 'on-line' light will be OFF when the Line Card is in Stand-by Mode. When the line card is on-line but not in communication, the on-line LED will FLASH to indicate that the buffer is full, or that there is a checksum error after download.

**LINE FAULT:** The 'Line Fault' light will come ON if the telephone line is disconnected. The 'Line Fault' light will turn OFF automatically when the telephone line is restored.

**TROUBLE:** The 'Trouble' light will come ON when the Line Card is shut down by an operator's command or when communication with the CPM2000 is interrupted. The 'Trouble' light will be shut OFF when the trouble condition is corrected.

**WATCHDOG:** The 'Watchdog' light will FLASH to indicate that Line Card operation is being monitored

**[ACK] Button:** Not used.

**[CANCEL] Button:** Not used.

**HANDSET:** Not used.

**DEBUG:** Connection to a PC for troubleshooting.

**[F1] + [F2] Buttons:** Press and hold both buttons simultaneously on power up for 10 seconds will reset the line card to factory default.

---

## Section 5 - DRL2000 Operating Mode

### 5.1 DRL2000 Standby Mode

After start-up the Line Card enters the Stand-by Mode and monitors the telephone line and the CPM2000. Depending on the system's status, the following conditions will be indicated:

- Line Fault light
- Trouble light: of Line Card communication problem with CPM2000

#### 5.1.1 Line Fault

The DRL2000 verifies the telephone line voltage. The 'Line Fault' light will come ON when the voltage drops below 12V.

If the Line Check option is enabled, the following information will be transmitted to the printer and computer:

- Printer:  
Jul 17 1998-08: 08: 28-SS/OO-SG-RR-LLL-0000-  
PHONE LINE TROUBLE

- Computer:ORRLLL[#0000;NLTSSOO][DC4]  
A hexadecimal number from 00 to 0B representing the slot number of the Line Card will be sent for each 'O' shown above.

A hexadecimal number from 01 to FE representing the shelf number of the Line Card will be sent for each 'S' shown above.

If the Line Check option is disabled, the DRL2000 will not send the report to the printer or computer. Refer to 'DRL2000 Programmable Features' for information on enabling the Line Check option.

When the line condition returns to normal, the 'Line Fault' light will be shut OFF.

If the Line Check option is enabled and the telephone line returns to normal, the following information will be transmitted to the printer and computer:

- Printer:  
Jul 17 1998 - 08: 08: 35-SS/OO-SG-RR-LLL-0000-  
PHONE LINE RESTORE
- Computer:ORRLLL[#0000;NLRSSOO][DC4]

#### 5.1.2 CPM2000 Error

If the DRL2000 cannot detect CPM2000 polling, the trouble light will come on.

If alarm messages cannot be sent to the CPM2000 because of the error, the DRL2000 will start buffering incoming calls.

Up to 256 alarm messages for the printer and computer will be retained in the DRL2000 event buffer. When the event buffer is full, the line card will stop answering the calls.

When the CPM2000 Error condition is corrected, the alarm messages in the event buffer will be transmitted to the CPM2000 with the corresponding time/ date the alarm have been received.

### 5.2 DRL2000 Cold Start-up

To perform a Cold Start-up, press the [F1] and [F2] buttons simultaneously for 10 seconds after a power up.

### 5.3 Communications in Progress

#### 5.3.1 Data Reception

During data reception, the on-line LED will turn on. The DRL2000 decodes all information received and stores the information in its Event Buffer. When a valid signal is received, the DRL2000 sends a kiss-off signal and transmits the decoded alarm signal to the computer and then to the printer through the CPM2000.

The DRL2000 will send each message it receives to the printer for review by the system operator. Two messages may be sent to the printer to indicate reception problems: the 'Fault Data' and 'Fault Call'.

#### 5.3.2 Fault Data Message

When this problem is encountered, the following information is transmitted to the printer and the computer:

- Printer:  
Jun 25 1998-11:18:07-SS/OO-SG-12-234-0000-  
INVALID REPORT

- Computer: 012234[#0000;NYNSSOO][DC4]  
This output for account code '0000' indicates that data has been received, but is not valid (for example, there are unmatched rounds or wrong parity).

#### 5.3.3 Fault Call

When this problem is encountered, the following information is transmitted to the printer and the computer:

- Printer:  
Jun 25 1998-11:18:07-SS/OO-SG-12-234-0000-  
COMMUNICATION FAIL
- Computer: ORRLLL[#0000;NYCSSOO] [DC4]

This output indicates that a call was received, but no data was detected. The call may have been a wrong number, or the calling control panel was unable to connect with the receiver's handshakes.

#### 5.3.4 Caller ID

When Caller-ID is enabled:

- Printer:  
19-Nov-1998 10:40:54 - Nov 19 1998-11:32:25-F3/  
00-SG -19-069-123F—
- Computer: 419069 123F0000000000

#### 5.3.5 Calling Name

When Calling name is enabled:

- Computer: u19069 123FSUR-GARD SECURT
- Printer:  
19-Nov-1998 10:40:56 - Nov 19 1998-11:32:25-F3/00-  
SG -19-069-123F—SUR-GARD SECURT

## Section 6 - Profiles

### 6.1 Introduction

The DRL2000 'virtual receiver' will load unique 'profiles' in order to effectively communicate with control panels. A profile is a set of pre-programmed line card options unique for a particular DNIS number. The 'DNIS' will point to a particular profile, which will then be loaded into the line card before the first handshake is sent. It is essential that the correct option be programmed for a profile in order to correctly communicate with the control panel. Each 'virtual receiver' can have a maximum of 64 profiles. To change the options for a particular profile, the Console software is provided. This software will allow the user/operator to edit the profiles.

**NOTE: DNIS (Dialled Number Identification Service).** This number represents the dialled number, or the number being called. **Caller ID:** This number identifies the source of a call. For the purpose of this document, Caller ID and ANI will be referred to as Caller ID, but both cannot be used at the same time. Caller ID cannot be used with DNIS. Contact your provider to determine which service is available.

DNIS or Caller ID can be used for profile selection.  
Line Cards Identification Number Handling:

Each profile is made up of Static Options and Dynamic Options. The static options are the same for all profiles, but the dynamic options can be programmed specifically per hunt groups, panel type, etc.

By receiving the DNIS or Caller ID, the appropriate profile can be selected through a look-up table "stored" on the line card.

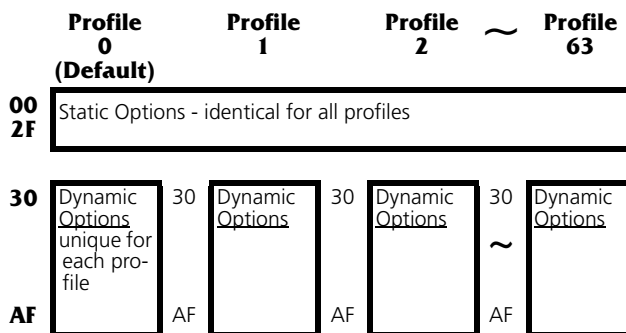

Profiles are used to reduce on-line time, and for specific customers or panel/format types, one can have a profile with certain handshakes sent first. Also, some formats require certain options, and this can be pre-defined as well.

Profiles allow for a more customized system. Rather than having a line card (or a receiver itself) devoted to certain customers, the DRL2000 can "handle" any format at any time through the use of profiles. Each line card holds its own look-up table that can be shared through line pools, or shared within the entire receiver.

Two types of tables are available, but only one type can be chosen. The first type, which consists of 10 000 entries, is used strictly with DNIS of up to 5-digits.

Table type 1:  
DNIS received Profile # to be used

DNIS Received	Profile# to be used
00001	01
00002	03
00003	24
...	...
99999	45

Figure 7, Call Processing Flowchart

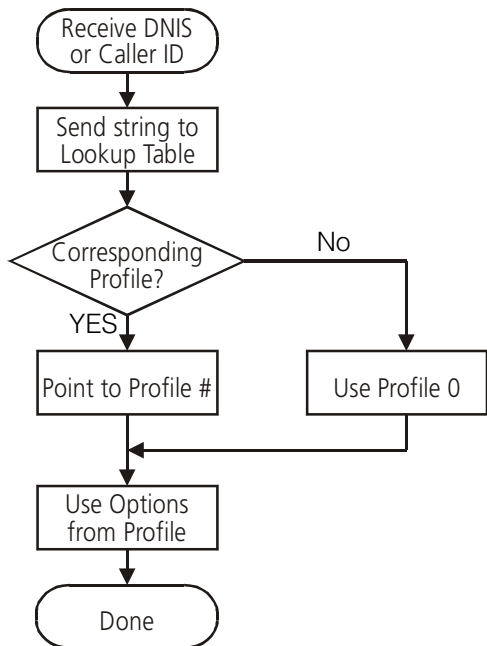

## 6.2 A.H.S. (Automatic Handshake Selection).

AHS is the process of the line card to send a handshake to be used with the ANI. Also included in AHS is the ability for the CPM2000 to "remember" which handshakes are used for which ANI.

The AHS has the ability to be used in conjunction with the DNIS to select a pre-defined profile based on the DNIS table that is stored in the line card. The handshake is retrieved from the AHS table, and the remainder of the options to be taken from the DNIS profile.

Also, if the panel does not respond to the handshake given by the line card, it will proceed with it's handshake sequence from this profile as opposed to the default profile.

The ANI database (Tel.dat), is one file that will consist of up to a maximum of 500 000 handshake entries. Each entry will be specific to a customer's telephone number, and will point to a particular handshake.

### 6.2.1 Hand Edit

Hand Edit can be used for manually entering and deleting entries from the Tel.dat file, and for creating the number of entries, in the database (up to 500 000). This file is then uploaded to the CPM2000 by FTP programs.

### 6.2.2 Tel.dat

The database file is referred to as Tel.dat. This is the binary file that holds all of the handshake entries (500 000). If the handshake is different for the same ANI number, the CPM2000 will change the Handshake programmed automatically.

For example; When the first call is made to the DRL2000, the first handshake sent by the line card could be 1400Hz. If the panel does not respond to this, it will go through its default handshake sequence. When a 2300Hz handshake is sent and the panel responds to it, the receiver will replace the old handshake with the new one.

### 6.2.3 Call Blocking

At any time the operator may want to use a call blocking type feature for particular customers (i.e. inactive accounts). The operator will be able to manually update the AHS database (Tel.dat) and enter handshake selections. If the operator wishes to call block a particular customer (Caller ID), they would do this by entering the handshake value 99. When this is sent to the line card, the line card will release the line.

- Computer Message:  
ORRRLL[#0000]ACPM 2000 BLOCKED CALL]
- Printer Message:  
RRLL-0000--CPM2000 BLOCKED CALL

## 6.3 Static Options: [00] - [2F]

### Option [00]: Reserved

### Option [01]: Line Card Number - Default [01]

The line card Number provides a virtual identification code for each DRL2000 module. Hexadecimal numbers '01' to 'FE' can be programmed in Option [01] to identify line cards.

### Option [02]: Line Card Number Length - Default [0A]

This option is used to determine how many digits from the line card number will be sent to the output. You also have the option of displaying the number in hex or decimal. Program Option 02 with one of the following:

- 01 Send only one Hex digit to the printer or computer output (if you have a 2-digit line card number only the last digit will be sent to the output)
- 02 Send 2 Hex digit line card number to the output
- 03 Send 3 Hex digit line card number to the output (leading Zeros will be inserted prior to the line card number)
- 0A Send 2-digit receiver number in decimal. 3 digits line number in decimal.
- 0D Send 2-digit receiver number as programmed. Send 3-digit line card number in decimal.
- 0E Send 2-digit receiver number in Hex. Send 1-digit line card number as follows: Line Card #

Line Card #	Send
1..F	1..F
10..1E	G..U

**NOTE:**When using the DRL2000, the Line Card Number Length option should always correspond to the number of DNIS digits being received.

For example, if 5 digits are being received then the Line Card Number Length Option should be programmed to 3 so that 1RRLLL will be overwritten by the 5 digits of DNIS and become 1dddd.

### Option [03]: Internal messages RS-232 - Default [01]

When this option is programmed as '00', the DRL2000 will output its internal messages in the following format:

SRRRLL[#AAAA]Nxxyy]

If it is programmed as '01' internal messages will be output as

ORRRLL[#AAAA]Nxxyy]

Where S, 0 (zero) = Protocol number

RR = Receiver number

LLL = Line number

AAAA = Account code, always 0000

Nxxyy = SIA event

### Option [04]: 2-Way Audio Activation Time - Default [00]

Option [04] determines how long, in 10-second increments, the 2-way audio function will be active once it is initiated. At the end of this time, the line card will hang up the line. Program a value from "01" to "FF" for 10 seconds to 2550 seconds. Three (3) minutes is the recommended length of time for the 2-way audio activation time. To disable the 2-way audio feature, program Option [04] as '00'.

**NOTE:**Enabling 2-way audio will affect NFPA 72 system loading requirements. Refer to Par. 4-5.3.2.2.2 of NFPA 72 for details.

### Option [05]: Pre-H.S. Duration - Default [0A]

When the line card seizes the line, it will wait the time programmed at Option [05]; then send the first handshake. The value programmed (hex) at this location will be multiplied by 100 ms. [e.g., 100 ms., 200 ms.] The default is 0A, for 1000ms (100ms x default value).

The minimum time is 1 second. If the option is programmed with any value lower than 0A, the line card will use a 1 second delay.

### Options [06] to [10]: Reserved

### Option [11]: Hook-flash Enable/Disable - Default [00]

Enables or disables ability to hookflash the phone line and determines its duration in increments of 10 ms.

If programmed as 00, the option is disabled. If set to anything else, you multiply the decimal equivalent of the hex value by 10 ms and that is the duration. For example, if hookflash time of 500 ms is wanted, program Option 2A to 32 Hex.

500 ms / 10 = 50

50 Dec = 32 Hex

### Option [12]: Caller Source ID Option - Default [00]

Option [12] allows the line card to receive Caller Identification data or DNIS that is transmitted after the first ring on the telephone line. The appropriate service must be available and requested from the Telephone Company for this feature to be operational.

- 00 Disabled
- 01 Standard Bellcore Caller ID
- 02 Reserved for future use
- 03 Reserved for future use
- 0X Receive X (4 to 10) digits DTMF DNIS
- 2X Receive DNIS and ANI in <DNIS>C<ANI>C
- 4X Receive ANI and DNIS in <ANI>C<DNIS>C

**NOTE:** A DNIS reception of C<DNIS>C will not be detected as DNIS only.

General messages other than Caller ID or DNIS:

- Private Call:** An anonymous indication is received instead of the originating telephone number.
- No Call No.:** An out-of-area or unavailable indication is received instead of the originating telephone number.
- Unknown Call:** The originating telephone number has not been received or was not transmitted.

### Option [13]: Caller Source to SG Computer - Default [00]

Option [13] allows the transmission of the Caller Identification or DNIS, to the computer output. Program Option [13] as one of the following:

- |    | Protocol |  |
|----|----------|--|
| 00 |          | Do not send to the computer                        |
| 01 | 4RRLLL   | Send to the computer using North American protocol |
| 02 | URRLLL   | Send to the computer using International protocol  |
| 04 | 4RRLLL   | Send ANI information to the computer               |

**NOTE:** Option [12] must be programmed as '01' to use Caller ID or '4x' to use ANI. Where 'x' represents the number of DNIS digits (including the terminator digit).

### Option [14]: Caller Source to printer - Default [00]

Option [14] allows the transmission of the Caller Identification or DNIS, to the printer output. Program Option [14] as one of the following:

- 00 Do not send to the printer
- 01 Send to the printer; each alarm will print an extra line, showing the Caller ID
- 04 Send to the printer; each alarm will print an extra line, showing the ANI number

**NOTE:** To use Option [14], Option [12] must be programmed as '01' for Caller ID or '4x' to use ANI. Where 'x' represents the number of DNIS digits (including the terminator digit).

### Option [17]: DMP User Length - Default [00]

Option 17 is for the variable length zone and user numbers. The first digit in the option represents the user number and the second digit represents the zone number. For example, if Option 17 is set for 24 then the receiver will output a 2-digit user number and a 4-digit zone number. The default value is 00 for 2-digit zone and 2-digit user number.

**NOTE:** This option will only apply to Serial 1 messages.

### Option [18]: SG 4/3 DTMF - Default [00]

- |     |  |
|-----|--|
|     | Upper nibble   |
| 0 = | do regular decoding (default)                                  |
| 1 = | perform group open/close decoding loser nibble                 |
|     | Lower nibble   |
| 0 = | no user conversions (default)                                  |
| 1 = | do SG4-3 user conversions                                      |
| 2 = | add 3 digit user code to automation                            |
| 3 = | add 3 digit user code to automation, do SG4-3 user conversions |

### Option [19]: Fault Call Counter - Default [00]

Option 19 is used for limiting the number of Fault Call messages that are sent to the printer and computer. The default setting will send a Fault Call alarm for every 10 Fault Calls. To have every Fault Call sent to the computer and printer set Option 19 to 01.

### Option [1A]: DNIS Input Sensitivity - Default [00]

Option 1A allows the user to change the DNIS reception window.

**NOTE:** Do not change this option unless instructed to do so by DSC Technical Support.

### Options [1B]: Reserved

### Option [1C]: Busy Out - Default [00]

This option allows the line card to seize the phone line in case of checksum error after download or when its internal buffer is full. Program Option [1C] with one of the following:

- 00 The line is seized if any of the conditions mentioned above occurs.
- 01 The line is NOT seized if any of the conditions mentioned above occurs.
- 02 Same as set to 00 when used with the Call Centre Feature configuration on the telephone interface module (SG-Paddle)
- 03 Same as set to 01 when used with the Call Centre Feature configuration on the telephone interface module (SG-Paddle)
- 05 The line will be seized if there is a loss of automation software or no communication to the CPM2000 ONLY if the internal computer buffer is full. If there is a loss of printer(s), any new alarms will not be buffered in the internal printer buffer. (note: the line card has two independent printer and computer buffers).

**NOTE:** If the option is programmed to 01, the line card will NOT buffer any new alarms once the internal buffer is full. Setting Option [1C] to 01 is NOT RECOMMENDED.

**NOTE:** If the option is programmed to 01, the line card will NOT buffer any new alarms once the internal buffer is full. Setting Option [1C] to 01 is NOT RECOMMENDED.

**CAUTION:** If your system uses the Call Centre Feature, and the option is set to 00, the line will always be seized.

**Option [1D]: Input Sensitivity - Default [1F]**

**Option [1E]: Output Levels - Default [C0]**

Db	Programming Value
+2.3	00
+1.1	20
-0.2	40
-1.8	60
-3.7	80
-4.9	90
-6.2	A0
-7.8	B0
-8.7	B8
-9.7	C0
-12.2	D0
-13.8	D8
-15.7	E0
-17.6	E6
-19.0	EA
-21.8	F0
-24.2	F4
-27.8	F8

**Option [1F]: Debug Output - Default [00]**

**Option [20]: C.L.A.S.S. Field Data - Default [04]**

Option [20]: C.L.A.S.S. Field Data This option determines how the Caller Source information is sent to the CPM via the E-bus. Program with one of the following:

- 00 Send 0's in C.L.A.S.S. field of Ebus
- 01 Send Receiver Line Card Number from options in C.L.A.S.S. field of Ebus
- 02 Send DNIS in C.L.A.S.S. field of Ebus
- 03 Send Caller ID in C.L.A.S.S. field of Ebus
- 04 Send whatever option [13] Caller Source is set to in the C.L.A.S.S. field of Ebus

**Options [21] - [26]: Internal Use Only**

**Option [27]: Caller Source Process - Default [05]**

This option determines how many digits of Caller ID or DNIS the receiver will process.  
0x - x is number of digits of DNIS or Caller ID to be processed (range from 1 to A hex)

**Options [28] - [29]: Reserved**

**Option [2A]: Hook-flash Delay - Default [00]**

Time delay before hang-up option. Option value x 100ms to a maximum of 9.5 seconds.

**Options [2B] - [2C]: Reserved**

**Option [2D]: A.H.S. - Default [00]**

A.H.S., Automatic Handshake Selection is the process of the line card to send a handshake to be used with the ANI. Also included in A.H.S. is the ability for the CPM2000 to "remember" which handshakes are used for which ANI.

The A.H.S. has the ability to be used in conjunction with the DNIS to select a predefined profile based on the DNIS table that is stored in the line card. The handshake is retrieved from the A.H.S. table, and the remainder of the options to be taken from the DNIS profile.

Also, if the panel does not respond to the handshake given by the line card, it will proceed with its handshake sequence from this profile as opposed to the default profile.

- 00 A.H.S. Disable
- 01 A.H.S. enable, 10 digits
- 02 A.H.S. enable international

**Call Blocking when A.H.S. is active**

At any time the operator may want to use a call blocking type feature for particular customers (i.e. inactive accounts). The operator will be able to manually update the A.H.S. database with the Hand Edit software. If the operator wishes to call block a particular customer (Caller ID), they would do this by entering for that entry the handshake value of 99. When this is sent to the line card, the line card will release the line as soon as it sees the Caller ID.

- Computer Message:  
ORRLL[#0000]ACPM 2000 BLOCKED CALL
- Printer Message:  
RRLL-0000--CPM2000 BLOCKED CALL

**Options [2E] - [2F]: Reserved**

**6.4 Dynamic Options: [30] - [FF]**

**Options [30] - [3F]: 3/1 - 4/1 Digit 0-F**

The DRL2000 uses a unique Sur-Gard communication format to transmit data through the CPM2000 to the central station computer. Event codes corresponding to alarm codes in 10 to 40 Baud formats and DTMF 4/1 to 4/3 formats are used in this unique format to enable the computer software to determine alarm types.

The DRL2000 will use the last digit of data received in 3/1 and 4/1 formats to determine the computer event code. The event code will then be transmitted to the central station computer. Refer to the DRL2000 Decoding Library for the complete set of event codes used by the DRL2000. In Sections [30] through [3F], program ASCII codes according to the Decoding Library. Do **NOT** use values other than 20-5C (ASCII).

Defaults:	Option	Value	Code
	30	41	A
	31	41	A
	32	41	A
	33	41	A
	34	41	A
	35	41	A
	36	41	A
	37	41	A
	38	41	A
	39	52	R
	3A	41	A
	3B	4F	O
	3C	43	C
	3D	5C	/
	3E	52	R
	3F	54	T

**Options [40] - [4F]: 3/2 - 4/2 Digit 0-F**

The DRL2000 will use the first digit following the account code in 4/2, 3/1 extended or 3/2 formats to determine the computer event code. The event code will then be transmitted to the central station computer. Refer to the DRL2000 Decoding Library for the complete set of event codes used by the DRL2000.

In Sections [40] through [4F], program ASCII codes according to the Decoding Library. Do **NOT** use values other than 20-5C (ASCII).

Defaults:	Option	Value	Code
	40	41	A
	41	41	A
	42	41	A
	43	41	A
	44	41	A
	45	41	A
	46	41	A
	47	41	A
	48	41	A
	49	52	R
	4A	41	A
	4B	4F	O
	4C	43	C
	4D	5C	/
	4E	52	R
	4F	54	T

**Options [50] - [5F]: 4/3 Digit 0-F**

The DRL2000 will use the fifth digit of data received in 4/3 formats to determine the message and event code. The event code will then be transmitted to the central station computer. Refer to the DRL2000 Decoding Library for the complete set of messages and event codes used by the DRL2000. In Sections [50] through [5F], program ASCII codes according to the **Decoding Library**. Do **NOT** use values other than 20-5C (ASCII).

**NOTE:** The old value programmed in each Option will not be changed until a command with valid data is received

Defaults:	Option	Value	Code
	50	41	A
	51	41	A
	52	41	A
	55	41	A
	54	41	A
	55	41	A
	56	41	A
	57	41	A
	58	41	A
	59	52	R
	5A	41	A
	5B	43	C
	5C	4F	O
	5D	42	B
	5E	54	T
	5F	5C	/

**Options [60] - [6F]: Printer Words.**

The English Printer Library is provided and can be selected by programming the event codes to the corresponding word.

For example, if the words 'exit fault' are required when the alarm code 1 is received in 3/1 (or 4/1 formats), Option [61] must be programmed as '87'.

**Refer to Appendix D for a list of available words.**

Defaults:	Option	Value	Words
	60	F2	PERIODIC TEST REPORT
	61	0A	FIRE ALARM
	62	14	PANIC ALARM
	66	1E	BURGLARY
	64	63	CLOSING
	65	62	OPENING
	66	E5	SERVICE
	67	00	MEDICAL
	68	E4	MESSAGE
	69	61	RESTORE
	6A	F2	PERIODIC TEST REPORT
	6B	C6	GROUP CLOSING

Defaults:	Option	Value	Words
	6C	C7	GROUP OPENING
	6D	E6	ZONE BYPASS
	6E	50	SYSTEM TROUBLE
	6F	A6	CANCEL

**Option [70]: Automation Common Event Code - Default [00]**

Some central station software packages are unable to process an alarm using the event codes listed in the DRL2000 Decoding Library. Where a central station monitors thousands of accounts belonging to different companies, the same reporting codes may have different meanings for different companies. Because of this, the individual event codes in Options [30] through [5F] cannot accurately represent the alarm condition. To overcome this, Option [70] may be programmed as indicated below:

**Program Operation:**

**00** - Use individual event codes to computer.

**20, 30-39 & 41-5A** - Use common event codes (space, 0-9, A-Z). When using common event codes, DSC recommends that either hexadecimal code '5A' (ASCII 'Z') or hexadecimal code '41' (ASCII 'A') be used. The 'Space' character (Hex 20) can be used as the common event code with certain automation software packages to avoid account code database changes when switching over from other brand receivers to the Sur-Gard receiver.

**NOTE:** Option [70] is ignored when using SIA, ITI, Contact-ID, ACRON, MODEM II, MODEM IIE, MODEM IIIa<sup>2</sup>, FBI Super Fast, BFSK, ADEMCO Super Fast and SK FSK1, 2 formats.

**Option [71]: Library Select - Default [04]**

Determines how to use Printer Words Options.

00 No printer words.

01 Printer words options used for 1-digit reporting code formats only; other will use pre-defined library.

02 Printer words options used for 2-digit reporting code formats only; other will use pre-defined library.

03 Printer words options used for 3-digit reporting code formats only; other will use pre-defined library.

04 Printer words options used for 1-digit and 2-digit reporting code formats only; other will use pre-defined library.

05 Printer words options used for 1-digit, 2-digit and 3-digit reporting code formats.

**NOTE:** Option [71] is ignored when using SIA, ITI, Contact-ID, ACRON, MODEM II, MODEM IIE, MODEM IIIa<sup>2</sup>, FBI SuperFast, BFSK, ADEMCO Super Fast and SK FSK1, 2 formats.

**Option [72]: SIA Option - Default [00]**

When this option is set to 01 the receiver will decode SIA Alarms sent without zone numbers and add 00 as the zone number to the automation output.

**Example 1:**

[#1234|Nri1BA]

Output: [#1234|Nri1BA00]

**Example 2:**

[#1234|Nri1BA01/RP]

Output: [#1234|Nri1BA01/RP00]

**Example 3:**

[#1234|Nri1BA/RP]

Output: [#1234|Nri1BA00/RP00]

When this option is set to 00 alarms sent without zone numbers will not be modified by the receiver.

**Example 4:**

[#1234|Nri1BA]

Output: [#1234|Nri1BA]

When set to 02 any account digit received as 'A' get converted to '0'.

**Example:**

**Received:** [A123|NriBA01]

**Output:** [0123|NriBA01]

When set to 03 any account digit received as 'A' get converted to '0' and alarms without zone numbers will have 00 added as the zone number.

**Example:**

**Received:** [A123|NriBA]

**Output:** [0123|NriBA00]

**Option [73]: Reserved**

**Option [74]: Equivalent Line Number - Default [00]**

The equivalent line number is used with the receiver number for sending signals to the central station software. This option can be used if there is no DNIS number being received by the line card.

**Option [75]: Receiver Number - Default [01]**

The receiver number is used for sending signals to the central station software. Refer to the manuals for any central station automation software being used to determine if there are any special requirements for this number. Also, check the numbers used for any other receivers in the station to ensure that numbers are not duplicated.

**Option [76]: Accounts 3/x to 4/x - Default [00]**

Program Option [76] with one of the values listed below: Value Function 00. If the alarm is reported in 3/1, 3/1 extended, 3/2, BFSK or 3/8 ACRON formats, a leading space will be communicated in front of the 3-digit Account Codes when sent to the computer.

**Ex: 101001ssssssAAAsXsssY[DC4]**

**01** If the alarm is reported in 3/1, 3/1 extended, 3/2, BFSK or 3/8 ACRON formats, a leading '0' (zero) will be communicated in front of the 3-digit Account Codes.

**Ex: 101001ssssss0AAAsXsssY[DC4]**

**02** If the alarm is reported in 3/1, 3/1 extended, 3/2, BFSK or 3/8 ACRON formats, a leading '0' (zero) will be communicated in front of the 3-digit Account. '0' (zero) will be communicated in front of the 1-digit alarm code.

**Ex: 101001ssssss0AAAsXss0Y[DC4]**

**04** If the alarm is reported in SIA then a leading '0' (zero) will be communicated in front of the 3-digit Account

**Ex: S01001[#0AAA|Nri0/FH00]**

**05** if the alarm is reported in 3/1, 3/1 extended, 3/2, BFSK, SIA or 3/8 ACRON formats then a leading '0' (zero) will be communicated in front of the 3-digit Account.

**06** if the alarm is reported in 3/1, 3/1 extended, 3/2, BFSK, SIA or 3/8 ACRON formats then a leading '0' (zero) will be communicated in front of the 3-digit Account and a '0' (zero) will be communicated in front of the 1-digit alarm code.

**Option [77]: Digit Replace - Default [00]**

Option 77 works in conjunction with Option A2. Option 77 is programmed with an ASCII value that will replace an account code digit or insert a value into an account code. Option A2 is used to replace a digit or insert a digit. To replace a digit use 0x where x is the digit to be replaced. To shift a digit use Option A2 and set to 8x where x is the location in the account code.

**Example 1:**

Option 77 is set for 41 and Option A2 is set for 01:

Standard 4/2-format output:

**1RRLLSsssssa1a2a3a4sXssYZ**

**Account code is 9876**

**1RRLLSssssss9876sXssYZ**

The receiver will do the following. First it will replace the first digit (Option A2=01) of the account code (in this example "1") and replace it with the ASCII value of 41, which is an "A".

New Output:

**1RRLLSsssssaA876sXssYZ**

**Example 2:**

To insert a digit use 8x where x is the spot where the digit is to be inserted.

Option 77 is set to 2D and Option A2 is set for 82:

**Account code is 9876**

**1RRLLSssssss9876sXssYZ**

The receiver will do the following, it will insert the ASCII value of Option 77, in this case the ASCII value of 2D (2D is a " - ") into position two (Option A2=82), and the account code will shift to the left. So it will convert account code 9876 as indicated below:

**1RRLLSssss9-876sXssYZ**

\* This will not affect SIA.

**Option [78]: Max Inter-digit - Default [00]**

Certain old dialers may have difficulties in communicating with the DRL2000 line cards. The DRL2000 provides a possible solution by programming this option. This option should be left as a default and should be changed only on the recommendation of a DSC technician. When programmed as 00, the inter-digit time is determined by the Baud rate of the format being used; all other values are in 100 ms. intervals. 0 determined by Baud rate (default).

- 00 auto
- 01 100 ms
- 02 200 ms
- .....
- 0A 1000 ms

**Option [79]: Max Inter-burst - Default [00]**

Certain old dialers may have difficulties in communicating with the DRL2000 line cards. The DRL2000 provides the possible solution by programming this option. This option should be left as default and should be changed only on the recommendation of a DSC technician. When programmed as 00, the inter-burst has a time of 100 ms, all other values are in 10 ms increments.

- 00 100 ms (default)
- 01 10 ms
- 02 20 ms... and so on

**Option [7A]: Account Codes to Activate 2-Way Audio - Default [00]**

Option [7A] determines which account codes will be able to activate the 2-way audio feature. Program the first digits of the desired account codes in Option [7A].

**For example:**

To allow all account codes between 1000 and 2FFF to activate the 2-way audio function, program Option [7A] as '12'.

To allow all account codes between 3000 and 6FFF to activate the 2-way audio function, program Option [7A] as '36'.

To disable the 2-way audio function, program Option [7A] as '00'.

**NOTE:** Option [7A] may be used with any formats supported by the MLR2000.

**Option [7B]: 3 Digit Account Codes to Activate 2-Way Audio - Default [00]**

Option [7B] determines which 3-digit account codes will be able to activate the 2-way audio feature. Program the first digits of the desired account codes in Option [7B].

**For example:**

To allow all 3-digits account codes between 200 and 3FF to activate the 2-way audio function, program Option [7B] as '23'.

To allow all 3-digit account codes between 300 and 6FF to activate the 2-way audio function, program Option [7B] as '36'.

Program Option [04] as '00' to disable this function.

**NOTE:** Option [7B] may be used with any 3-digit account code formats supported by the MLR2000.

**Option [7C]: Alarm Codes to Activate 2-Way Audio - Default [00]**

Option [7C] determines the range of alarm codes, which will activate the 2-way audio function. Program the first digits of the desired alarm codes in Option [7C].

**For example:**

The DRL2000 will initiate audio by the account range, Options [7A] and [7B] or by Option [7C] ALARM CODE or by both.

If all alarm codes beginning with 6, 7 and 8 are to activate 2-way audio, program Option [7C] as '68'. Option [7C] may be used with 10 to 40 Baud formats, DTMF 4/1, 4/2, and 4/3 formats.

Program Option [7C] as '00' to disable this function.

**Example:**

4/2 format with account code 1234, alarm code 2 on zone 3. (1234-23)

**Option - [7A] [7C] Switch Reason (or [7B]) to Audio**

Option [7A]/[7B]	Option [7C]	Switch to Audio	Reason
00	1-2	Yes	Alarm code 2 falls within the code range 1-2.
1-1	00	Yes	Account code 1234 falls within the range 1-1.
2-3	00	No	Account code 1234 is outside the range 2-3.
00	3-4	No	Alarm code 2 is outside the range 3-4.
1-2	3-4	No	If both are programmed, both must be good and alarm code 2 is outside the range 3-4.
3-5	1-3	1-3	Both must be good and account code 1234 is outside the range 3-5.
			Alarm code 2 falls within the code range 1-5, account code 1234 falls within the range 1-4.
1-4	1-5	Yes	

**Option [7D]: Audio Zone Code - Default [00]**

Audio zone code is the range of zone codes that will activate audio. The first digit is the lowest code. The second digit indicates the highest zone that will activate audio. Option [7D] may be used with 10 to 40 Baud formats, DTMF 4/1, 4/2, and 4/3 formats.

**Option [7E] Audio RS-232 - Default [00]**

This is the code sent to the automation software that indicates that two-way audio has been initiated. If this option is set to '00' there will be no audio-initiated message sent to the automation output. If set to 01, the automation message for audio will be generated with protocol ID 'S'. If set to 02, the automation message will be generated with protocol ID '0'.

- 00 No Automation Output
- 01 Send SRLLLL[#AAAA|NLFssoo][DC4]
- 02 Send ORLLLL[#AAAA|NLFssoo][DC4]

**Option [7F]: Audio Format Enable - Default [00]**

This option gives you the ability to enable and disable audio for selected formats. A '1' in the formats bit position will enable the format for audio. A '0' in the formats bit position will disable audio for the format.

- Bit 0 3 Digit pulse format
- Bit 1 4 Digit pulse format
- Bit 2 DTMF format
- Bit 3 Contact ID
- Bit 4 SIA format
- Bit 5 Modem II format
- Bit 6 ITI Format
- Bit 7 Westec format

**For example:** if the user wants audio to work only for 3-digit pulse and SIA formats, Option 7F would have to be programmed as 11 hex which enables bit 0 and bit 4.

**Option 80: Kiss-Off to Hang-up Time - Default [1F]**

This option determines the delay between Kiss-off and the release of the line. The hex value programmed at this location will be converted to decimal and then multiplied by 100 milliseconds to generate the delay.

**For example:**

Option 80 = 0A Hex = 10 decimal \* 100 ms = 1000 ms = 1 second delay

Option 80 = 28 Hex = 40 decimal \* 100 ms = 4000 ms = 4 second delay

**Options [81] through [88]: Handshake Selection - Defaults:**

[81]	23	[85]	0E
[82]	14	[86]	0B
[83]	2D	[87]	00
[84]	0C	[88]	00

The DRL2000 is a multi-format receiver capable of sending several handshakes to a dialer. Often it is important which handshake is sent first. Program Options [81] through [88] according to your applications. Handshake Options:

- 00 No handshake
- 2D Double dual-tone handshake
- 0C SIA FSK handshake
- 0B Modem II handshake
- 0E Modem IIE and ITI handshake
- 1D Single dual-tone handshake
- 0F DMP handshake

All other frequencies can be programmed using the first two digits to represent the 3rd and 4th decimal places.

**Example:**

- 23 2300 Hz
- 18 1800 Hz
- 14 1400 Hz
- 10 1000 Hz

**Option [89] to [90]: Handshake and Kiss-off Duration - Default [00]**

Some control panels may require a different handshake duration. Each unit has increments of 100 ms, from 100 ms to a maximum of 8.1 seconds. Program Options 88 to 90 for the desired duration.

- 00 1 second
- 01 100 ms
- 02 200 ms
- 03 300 ms
- 04 400 ms
- 0A 1 second.
- 0C 1.2 second.... and so on

DSC does not recommend programmed durations longer than 1.5 seconds, as it may not be tolerated by the alarm panel. For special applications, it may be necessary, but any durations higher than 8.1 seconds will not be accurate and may not match the duration programmed.

**NOTE:** These options will only affect steady tones handshakes.

- Option [89]: Handshake #1 duration
- Option [8A]: Handshake #2 duration
- Option [8B]: Handshake #3 duration
- Option [8C]: Handshake #4 duration
- Option [8D]: Handshake #5 duration
- Option [8E]: Handshake #6 duration
- Option [8F]: Handshake #7 duration
- Option [90]: Handshake #8 duration

**Option [91]: Inter-Handshake Duration - Default [00]**

The DRL2000 line card will usually wait for signals from the control panels for 4 seconds before sending the next handshake, if there are no signals received. In certain applications, control panels cannot wait long enough to get its own handshake especially if the handshake is programmed as the fifth or later handshake. Program Option [91] with one of the following:

- 00 4-second interval
- 01 1-second interval
- 02 2-second interval
- 03 3-second interval

**Option [92]: Pulse Decoding Only - Default [00]**

When this option is enabled the DRL2000 line card will only detect pulse formats. When programmed as 02, special ADT pulse formats will be enabled. This option should be left as default unless instructed by DSC Technical Support.

Set this option to x where x = 1 to F to specify the minimum burst to be rejected as 1-15 ms.

**Option [93]: Min Audio Tone - Default [00]**

This option is used for Two-way audio tone detection from specific audio panels. This option should be left as default unless otherwise instructed by DSC Technical Support.

**Option [94]: Account Digit Stripping - Default [00]**

When Option 94 is set to 01, the leading digit of a four-digit account code will be stripped if it is an F.

**Example:**

Standard 4/2 format Output:  
1RRLLssssssAAAAxXssYZ

**Example 1:**

Option 94 set to 00  
Panel account code is F245  
101001ssssssF245sXssYZ

If Option 94 is set to 01 the 'F' will be replaced by a space and the value of "A" will be decoded as "A" but not "0".

This setting will also enable the receiver to decode special pulse extended-extended formats.

101001ssssss245sXssYZ

If Option 94 is set to 02 than the leading zero of a four-digit panel account code will be stripped. This option will work with the following formats:

- Standard Pulse and DTMF(3/x, 4/x & Extended)
- FBI
- Ademco Super Fast (4/8/1, 4/8)
- Contact ID

- ITI
- SIA
- Modem II
- SKFSK

**Example 1:**

Option 94 set to 02  
Panel account code is 0345  
101001ssssss0345sXssYZ

**New Output:**

101001ssssss345sXssYZ

**Option [95]: 5-Digit Pulse - Default [00]**

The DRL2000 cannot distinguish between 4/1, 3/2 and 3/1 with checksum because all of them contain a total of 5 digits. Therefore, this option must be programmed to inform the DRL2000 which of the 3 formats may be used.

- Option 95 (3/2 Format)
- 00 select 4/1 format
- 01 select 3/2 format
- 02 select 3/1 with checksum format
- 03 For 40 baud, select 311 with checksum. Otherwise select 4/1 format.

**NOTE:** The printer messages for the 3-2 format are the same as those used for the 4/2 format.

**Option [96]: 4/1 Extended - Default [00]**

Program Option [96] as '01' to combine 2 round pairs of 4/1 extended format into 4/2 output for reporting to the computer and the printer. For example, with Option [96] enabled, the security control panel may transmit the following information:

1234	3
1234	3
3333	1
3333	1

The DRL2000 will interpret this information as: 123 31; the default setting for Option [98] is '01'; when programmed as '00', the option is disabled.

**Option [97]: 4/2 Extended - Default [00]**

Program Option [97] as '01' to combine 2 round pairs of 4/2 extended format into 4/3 output for reporting to the computer and the printer. Program one of the following:  
00 4/2: Extended format data is not combined.

**01: The panel will send:**

1234	05
1234	05
0505	16
0505	16

The DRL2000 will interpret this information as 1234 516, or the panel will send:

1234	03
1234	03
3333	01
3333	01

The DRL2000 will interpret this information as 1234 301. Note that a longer on-line time is required for this format than for a standard 4/2 format. The default setting for Option [97] is '00'; when programmed as '00', the option is disabled.

**Option [98]: 3/1 Extend - Default [01]**

Program Option [98] as '01' to combine 2 round pairs of 3/1 extended or 3/1 partial extended format into 3/2 output for reporting to the computer and the printer. For example, with Option [98] enabled, the security control panel may transmit the following information:

```
123    3
123    3
333    1
333    1
```

The DRL2000 will interpret this information as: 123 31; the default setting for Option [98] is '01'; when programmed as '00', the option is disabled.

**Option [99]: Ademco Express - Default [01]**

The Ademco 4/1 Express format may cause conflicts with the Sur-Gard DTMF 4/3 with checksum format or FBI Super fast without checksum. Therefore, this option must be programmed to inform the DRL2000 which of the 3 formats may be used.

- 00 Sur-Gard DTMF 4/3 with checksum
- 01 Ademco 4/1 Express
- 02 FBI without checksum

**Option [9A]: Error Counter - Default [00]**

Program this option to determine the number of bad rounds from a pulse communicator the line card will receive before hanging up.

**Option [9B]: Echo Cancellor - Default [00]**

- 00 Disabled
- 01 Enabled: The echo suppression option will enable the transmission of a two-second 2025 Hz tone from the line card to disable echo suppression equipment.

**Option [9C]: Acron RS-232 - Default [01]**

When this option is programmed as '00', the DRL2000 will convert the Acron Super Fast format signal into 3/2 or 4/2 format (Ex: AAAAsXssYY[DC4] ). If it is programmed as '01' the Acron Super Fast will be sent to the computer as indicated below:

**9RRLLSsssAAAACCCCCCCC[DC4]**

Where 9 = protocol number  
 RR = receiver number  
 LLL = line number  
 ssss = spaces  
 AAAA = account code  
 CCCC = channel 1-4  
 CCCC = channel 5-8  
 [DC4] = terminator

**Option [9D]: MODEM II RS-232 - Default [01]**

The DRL2000 is able to decode the Modem II formats. The handshake 0B needs to be programmed as one of the handshakes of the DRL2000 for the Modem II and handshake 0E for Modem IIE or Modem IIIa<sup>2</sup>. Option [9D] determines the protocol sent to the computer. Note that this option will also affect the BFSK format only if programmed as 00 or 01.

- 00 6500 protocol: 1RRLLSsssAAAAXYYYY[DC4]
- 01 SG protocol: 6RRLLSsssAAAAXYYYY[DC4]
- 02 ModemII to SIA protocol
- 03 ModemII to SIA protocol, and text is decoded and sent to printer and computer.

**NOTE:** Ensure that the automation software supports settings 02 and 03 if the SIA protocol is desired.

**Option [9E]: Reserved**

**Option [9F]: Ademco High Speed RS-232 - Default [01]**

When this option is programmed as '00', the DRL2000 will convert the High Speed format signal into 4/2 format (E.g. 1RRLLSsssAAAAsXssYY[DC4]). If it is programmed as '01' the Ademco High Speed will be sent to the computer as indicated below:

**8RRLLAAAAsCCCCsCCCCsC[DC4]**

Where 8 = protocol number  
 RR = receiver number  
 LLL = line number  
 AAAA = account code  
 CCCC = channel 1-4  
 s = space  
 CCCC = channel 5-8  
 s = space  
 C = Channel 9  
 [DC4] terminator

**Option [A0]: Reserved**

**Option [A1]: FBI RS-232 - Default [01]**

To enable the computer for FBI Super Fast protocol, program Option [A1] as '01'. When enabled, the computer output will be as indicated below:

**JRRLLSsssAAAATZZEss[DC4]**

Where:  
 J = FBI protocol identifier  
 RR = receiver number  
 LLL = line number  
 s = spaces  
 AAAA = account code  
 T = zone type  
 ZZ = zone number, in hex.  
 E = event code  
 if E = 0 and T = 0 : listen in.

**Option [A2]: Digit Replace - Default [00]**

Option 77 works in conjunction with Option A2. Option 77 is programmed with an ASCII value that will replace an account code digit or insert a value into an account code. Option A2 is used to replace a digit or insert a digit. To replace a digit use 0x where x is the digit to be replaced. To shift a digit use Option A2 and set to 8x where x is the location in the account code.

**Option [A3]: D6500 RS-232 - Default [00]**

This option is used to strip hex digits on the automation output. The DRL2000 will emulate the Radionics 6500 RS-232 protocol on pulse formats and Varitech only. When Option A3 is set to 01 the hex digit will be stripped for 1-digit reporting codes including Varitech 4/1.

**Example 1:** Code 1  
 Computer output: 104091ssssss022sAsss1

**Example 2:** Code B  
 Computer output: 104091ssssss022sOssss

If Option A3 set to 02: the hex digit will be stripped for 2-digit reporting codes including Varitech 4/2.

**Example 1:** Code 21  
 Computer output: 104091ssssss022sAss21

**Example 2:** Code B1

Computer output: 104091ssssss022sOsss1

If Option A3 set to 03: the hex digit will be stripped for 1 and 2-digit reporting codes including Varitech.

If Option A3 set to 04: the hex digit will be stripped for BFSK.

**NOTE:** This option will only work if Option A4 is set to 01.

**Example 1:** Code 21

Computer output: 604091ssssss022sAss21

**Example 2:** Code B1

Computer output: 604091ssssss022sOsss1

If Option A3 is set to 05: the hex digit will be stripped for 1-digit reporting and BFSK.

If Option A3 is set to 06: the hex digit will be stripped for 2-digit reporting and BFSK.

If Option A3 set to 07: the hex digit will be stripped for 1-digit, 2-digit and BFSK.

**NOTE:** Option [70] must be left as an individual event code when enabling this option.

**Option [A4]: BFSK RS-232 - Default [00]**

When programming Option [A4] as '00', the BFSK format will be reported as Radionics 6500 BFSK mode to the computer; the protocol identifier will be a 6.

**Example 1:** Code 21

Computer Output: 604091 022sAsss1

**Example 2:** Code B1

Computer Output: 604091 022sOsss1

When Option A4 set to 01, the BFSK will be reported as a standard 3/1 extended format, the protocol identifier will also be changed from 6 to 1.

**Example 1:** Code 21

Computer Output: 104091 022sAss21

**Example 2:** Code B1

Computer Output: 104091 022sOssB1

**Option [A5]: Sescoa Super Speed - Default [01]**

If set to 00 Sescoa Super Speed will be disabled and 4/2 with checksum will be enabled.

If set to 01, Sescoa Super Speed will be enabled and 4/2 with checksum will be disabled.

**Option [A6]: ITI Adjust - Default [00]**

When set to 01, the ITI account codes will be converted to four digits by stripping the last digit off. For example, a panel account of 23459 will become account 2345. If the leading digit of the panel account is a 0 than it will be stripped and replaced with a space. For example, if 02349 is sent then the receiver will output 234 for the panel account.

**Option [A7]: Silent Knight FSK2 RS-232 - Default [00]**

The DRL2000 provides two possible outputs to the computer for Silent Knight FSK2 format. The operation of this option is explained below:

[A7] = 00	SKFSK disabled
[A7] = 01	SKFSK enabled for:
	SKFSK1
	ERRLLLssssssAAAAYYssss[DC4]
	SKFSK2 Protocol #2
	CRRLLLssssAAAAAYYZss[DC4]
[A7] = 02	SKFSK enabled for:
	SKFSK1
	ERRLLLssssssAAAAYYssss[DC4]
	SKFSK2 Protocol #2
	FRRLLLssssAAAAAYYZss[DC4]

**Options [A8] - [AF]: Dial-out Number For 2-way Audio Transfer - Default [00]**

These 8 options are used to provide the dial-out number if the user wishes to transfer the call to another extension. Up to 16 digits may be programmed including any 'Feature Command' digits. The values in these options will be sent as DTMF tones on the phone line after the following sequence takes place:

- 1 The DRL2000 has recognized the current call as a 2-way audio account and alarm code.
- 2 The calling control panel has finished sending its alarms and switched into 2-way audio mode.
- 3 The DRL2000 will perform a Hook-flash with the time value as programmed in Option 11 and then start to dial the digits programmed in Options A8-AF.

Options A8-AF must be programmed in the following manner: Digits 1-9 are programmed as the numbers 1-9. The digit 'A' must be programmed if a zero is needed anywhere in the dial string as the digit zero is used to indicate to the line card that there are no more digits to dial. If a '\*' is needed, (e.g., \*70, the transfer command in some PBX/PABX switches) program a 'B'. Similarly, if a '#' is needed, program a 'C'.

To get the line card to wait for 3 seconds in a dial string, program a 'D'. For example: to have the line card transfer a 2-way audio call to Ext. 51386, with a 3 second pause between the transfer command and dialing, Options A8-AF would be programmed as the following:

A8 = B7	AC = 60
A9 = AE	AD = 00
AA = 51	AE = 00
AB = 38	AF = 00

## Section 7 - DRL2000 Communication Formats

### 7.1 Common Formats

The following formats are commonly used:

- 3/1, 4/1, 4/2 formats; 10, 14, 20 Baud
- 3/1 extended format; 10, 14, 20, 40 Baud.
- 3/1, 4/2 formats with or without checksum; 40 Baud
- 3-2 format; 10, 14, 20 Baud (option)
- 4/1 Extended format; 10, 14, 20 Baud (option)
- 4/2 Extended format; 10, 14, 20, 40 Baud (option)

Example:

- 3/1 FORMAT  
Computer: 1011ssssss123sAsss1[14]  
Printer: Jun 26 1998-13:42:32-01/02-SG - 01-123-123-
- 1-FIRE ALARM
- 3/1 EXTENDED FORMAT  
Computer: 1011ssssss123sAss32[14]  
Printer: Jun26 1998-13:49:38-01/02-SG - 01-123-123-
- 32-BURGLARY
- 4/2 FORMAT  
Computer: 1011ssssss1234sAss22[14]  
Printer: Jun 26 1998-15:02:23-01/02-SG - 01-123-1234-
- 22-PANIC ALARM

### 7.2 Sur-Gard DTMF Formats

Sur-Gard DTMF 4/3 and 4/3 with checksum formats provide fast, reliable and easy-to-understand and decode data transmission. On-line time will be greatly reduced when using 4/3 and 4/3 with checksum formats. The 4/1 and 4/2 DTMF formats can also be decoded by the DRL2000.

The 4/3 with checksum format is recommended for use with Sur-Gard and DSC security control panels.

Example:

- Sur-Gard 4/3 format  
Each round pair represents a single event:  
AAAAEZZ  
AAAA = 4-digit account code.

E= Event code.

ZZ = Zone number or user number.

Computer: 1011ssssss2255sAs266[14][6]

Printer: Jun 25 1998-13:20:42-01/02-SG - 01-123-2255266-PANIC ALARM

### 7.3 Acron Format

The Acron format is a DTMF format. It can transmit 3 or 4 account digits and 8 digits of channel status at a time.

Shown below are several examples of Acron transmissions.

- Handshake / Kiss-off: 2300 Hz
- 1234: Account Code

Example:

- AAAAZZZZZZZZorAAAZZZZZZZZ
- 9RRLLSsssAAAACCCCCCCC[DC4]
- With option disabled

4/8

Computer: 101123ssssss1234sCssA1[14][6]

Printer: Jun 25 1998-13:25:12-01/02-SG - 01-123-1234-A1-CLOSEsUSERS01

- With option enabled

4/8

Computer:901123ssss1234AAAAA78A[14][6]

### 7.4 Ademco Contact ID

This DTMF format requires a dual tone handshake and 1400 Hz kiss-off, or 1400 Hz handshake and 1400 Hz kiss-off.

NOTE: If the dialer responds to a 2300 Hz handshake by sending the Contact ID Format data, the DRL2000 will accept and decode the format. The DRL2000 will send a 1400 Hz kiss-off tone regardless of the handshake.

EVENT CODE CLASSIFICATIONS

CONTACT ID

The Event codes have been grouped according to the type of event (see Event Code Library below).

### Contact ID Event Code Library

<b>Medical Alarms - 100</b>		121	Duress	141	Polling loop open
100	Medical	122	Silent	142	Polling loop short
101	Pendant transmitter	123	Audible	143	Expansion module failure
102	Fail to report in	<b>Burglar Alarms - 130</b>		144	Sensor tamper
<b>Fire Alarms - 110</b>		130	Burglary	145	Expansion module tamper
110	Fire alarm	131	Perimeter	146	Silent Alarm
111	Smoke	132	Interior	<b>24 Hour Non-Burglary - 150 and 160</b>	
112	Combustion	133	24 Hour	150	24 Hour non-burg
113	Water Flow	134	Entry/Exit	151	Gas detected
114	Heat	135	Day/Night	152	Refrigeration
115	Pull Station	136	Outdoor	153	Loss of heat
116	Duct	137	Tamper	154	Water leakage
117	Flame	138	Near alarm	155	Foil break
118	Near alarm	139	Silent Burg	156	Day trouble
<b>Panic Alarms - 120</b>		<b>General Alarms</b>		157	Low bottled gas level
120	Panic alar	140	General alarm	158	High temp

159	Low temp	355	Loss of radio supervision	456	O/C Partial Arm
161	Loss of air flow	356	Loss of central polling	457	exit Error
<b>Fire supervisory - 200 and 210</b>		357	Radio Xmtr VSWR	458	User on Premises
200	Fire supervisory	<b>Protection Loop Troubles - 370</b>		459	Recent Close
201	Low water pressure	370	Protection loop	<b>System Disables - 500 and 510</b>	
202	Low CO2	371	Protection loop open	<b>Sounder/Relay disables - 520</b>	
203	Gate valve sensor	372	Protection loop short	520	Sounder/Relay disabl
204	Low water level	373	Fire trouble	521	Bell 1 disable
205	Pump activated	374	Exit Alarm	522	Bell 2 disable
206	Pump failure	<b>Sensor Troubles- 380</b>		523	Alarm relay disable
<b>System Troubles - 300 and 310</b>		380	Sensor trouble	524	Trouble relay disable
300	System trouble	381	Loss of super. - RF	525	Reversing relay disable
301	AC loss	382	Loss of super. - RPM	<b>System peripheral Disables - 530 and 540</b>	
302	Low system battery	383	Sensor tamper	<b>Communication Disables - 550 and 560</b>	
303	RAM checksum bad	384	RF xmtr. low battery	551	Dialer disabled
304	ROM checksum bad	385	Smoke Hi-Sens.	552	Radio xmitter disabled
305	System reset	386	Smoke Low Sens.	<b>Bypasses - 570</b>	
306	Panel program changed	387	Intrusion Hi-Sens.	570	Zone bypass
307	Self-test failure	388	Intrusion Low Sens.	571	Fire bypass
308	System shutdown	389	Detector Self Test Fail	572	24 Hour zone bypass
309	Battery test failure	<b>Open/close - 400</b>		573	Burg. bypass
310	Ground fault	400	Open/Close	574	Group bypass
<b>Sounder/Relay Troubles - 320</b>		401	O/C by user	575	Swinger Bypass
320	Sounder/relay	402	Group O/C	<b>Test/Misc. - 600</b>	
321	Bell 1	403	Automatic O/C	601	Manual trigger test
322	Bell 2	404	Late to O/C	602	Periodic test report
323	Alarm relay	405	Deferred O/C	603	Periodic RF Xmission
324	Trouble relay	406	Cancel	604	Fire test
325	Reversing	407	Remote arm/disarm	605	Status report to follow
<b>System Peripheral Troubles - 330 and 340</b>		408	Quick Arm	606	Listen-in to follow
330	System Peripheral	409	Keyswitch O/C	607	Walk Test Mode
331	Polling loop open	<b>Remote Access - 410</b>		608	OFF normal condition
332	Polling loop short	411	Callback request made	609	Video transmitter active
333	Exp. module failure	412	Succes - download access	611	Fire test: point tested
334	Repeater failure	413	Unsuccessful access	612	Fire test: point not tested
335	Local printer paper out	414	System shutdown	621	Event log reset
336	Local printer failure	415	Dialer shutdown	622	Event log 50% full
337	Exp Mod DC Loss	<b>Access Control - 420</b>		623	Event log 90% full
338	Exp ModLow Batt	421	Access denied	624	Event log overflow
339	Exp Mod Reset	422	Access report by user	625	Time/Date Reset
341	Exp Mod Tamper	<b>Special O/C - 440-450</b>		626	Time/Date inaccurate
<b>Communication Troubles - 350 and 360</b>		441	Armed Stay	627	Program mode Entry
350	Communication	450	O/C by Exception	628	Program mode Exit
351	Telco 1 fault	451	Early O/C	629	1 & 1/3 day no read log
352	Telco 2 fault	452	Late O/C	630	Sched change
353	Long range radio	453	Fail to O/C	631	Exception Schedule change
354	Fail to communicate	455	Auto Arm Fail	632	Access Sched change

Example:

- COMPUTER: 501123s181234E12200003[14][6]
- PRINTER: Jun 26 1998-16:07:35-01/02-SG - 01-123-1234-122-E122-00sSILENT PANIC 003

## 7.5 Ademco Express

This format consists of 4-digit account codes and 1- or 2-digit alarm codes. The DRL2000 will decode the signal as regular 4/1 or 4/2 format. Option [99] must be programmed as '01' to decode the 4/1 Express format instead of the Sur-Gard 4/3 with checksum format.

Example:

- Option 99 set to 00  
Raw data: 23451726  
Computer Output: 101123 2345 A 172  
Printer Output: Jul 20 1998-15:54:31-01/02-SG - 01-123-2345-172-FIRE ALARM
- Option 99 set to 01  
Raw data: 23451726  
Computer Output: 101123 2345 A 2  
Printer Output: Jul 20 1998-15:48:57-01/02-SG - 01-123-2345-2-PANIC ALARM

## 7.6 Ademco Super Fast (High Speed Format)

The High Speed format consists of 4 digit account numbers, 8 channel status digits, and 1 auxiliary channel.

**NOTE:** When option [9F] is programmed as '00', the DRL2000 will convert the signal into 4/2 format. When option [9F] is programmed as '01', the DRL2000 will send the information as it received to the printer and to the computer using High Speed RS-232 communication protocol.

8RRLLLAAAAsCCCCsC[DC4]

AAAAZZZZ ZZZZ S

AAAA = Three digit or four digit account number.

ZZZZ ZZZZ = Zone status.

S = Status channel indicates the meaning of the message.

AAAAZZZZZZZS or AAAZZZZZZZS

Example:

- With option 9F disabled  
Computer: 101001sssss1234sAss02[14][6]  
Printer: Jun 25 1998-14:17:50-F3/00-SG-01-123-1234-02-ALARM ZONE02
- With option 9F enabled  
Computer: 801001 1234s5155s5555s7[14][6]  
Printer: Jun 25 1998-14:21:50-01/02-SG - 01-123-1234- 515555557

## 7.7 FBI Super Fast Format

This DTMF format consists of 4-digit account codes, 2-digit zone codes, 1-digit zone type codes, and 1-digit event codes. The zone codes will be converted into 3-digit decimal codes by the DRL2000.

The following are the zone type codes used by this format:

FBI Event	Code	Converted Event Code
Fire	1	A
Panic	2	A
Burglary	3	A
Medical	4	A
Auxiliary	5	A
Bypass	6	B
Inactive	7	A
Eight	8	A

FBI Event	Code	Converted Event Code
Nine	9	A
Zero	0	A
Opening	B	O
Closing	C	C
Abort	D	T
Restore	E	R
Trouble	F	T

**NOTE:** Note that option [A1] can give a unique FBI RS232 output when enable.

Example:

- FBI RS232 Option On  
Computer:JO112323452032 [14]  
Printer: 20-Jul-1998 13:12:29 - Jul 20 1998-13:14:51 -01/-2-SG - 01-123-2345-003-PANIC
- FBI RS232 Option Off  
Computer:101123 2345 O 001 [14]  
Printer:20-Jul-1998 13:52:35 - Jul 20 1998-13:54:57-01/02-SG - 01-123-2345-001-OPENING

## 7.8 ITI Format

The ITI format covers ITI panels listed in Appendix E. In order to receive the ITI format, the handshake #10 must be programmed.

## 7.9 ITI Sensor Library

Sensor #Printed Out AsSpecifics

00	Buddy AlarmSX-V Only
01-32	ALARMCaretaker Plus
00-16	AlarmRF Commander/ Commander III
02-07	AlarmSX-IVB
01	Bad Sensor #SX-V Only
02-76	AlmSX-V
01-18	AlarmCommander 2000
01-76	AlarmUltraGard 5000
77	AlarmTmprCaretaker Plus, SX-IVB, SX-V, UltraGard 5000 Only
78	TroubleCaretaker Plus, UltraGard 5000 Only
79	No Activ AlmCaretaker Plus, UltraGard 5000 Only
80	AlarmALL Supported ITI Panels
81	AlarmALL Supported ITI Panels
82	AlarmALL Supported ITI Panels
83	PhoneTstALL Supported ITI Panels
84	OpenUsr xxALL Supported ITI Panels
85	CloseUsr xxALL Supported ITI Panels
86	SilentDuressALL Supported ITI Panels
87	Force Arm, ALL Supported ITI Panels Auto ForceArm
88	TroubleCaretaker Plus, UltraGard 5000 Only
89	RF TouchpadCaretaker Plus, UltraGard 5000 Only
90	AC FailALL Supported ITI Panels
91	Low BatteryALL Supported ITI Panels
92	AlmTmprLoopALL Supported ITI Panels
93	AutoPhoneTstALL Supported ITI Panels
94	Recevier FailureALL Supported ITI Panels
95	CPU Back InALL Supported ITI Panels
98	Event Dump ReportCommander 2000 Only.

**NOTE:** The UltraGard 5000 and the Security Pro5000 are the same panel with different marketing names. Therefore all references above to the UltraGard 5000 include the Security Pro5000.

## 7.10 Modem II, Modem IIE, Modem IIIa<sup>2</sup> and BFSK Formats

BFSK, Modem II, Modem IIIa<sup>2</sup> or Modem IIE formats (refer to appendix D) can be decoded by the DRL2000.

### 7.10.1 Modem II

Example:

- Modem II RS-232 Option ON  
Computer Output: 601001 7112 T 9[14]  
Printer Output: 23-Jun-1998 09:49:02 - Jun 23 1998 -09:53:00-01/02-SG - 01-123-7112-BATTERY MISSING
- Modem II RS 232 option OFF  
Computer Output: 101001 7112 R F01[14]  
Printer Output: 23-Jun-1998 11:07:47 - Jun 23 1998-11:11:45-01/02-SG - 01-123-7112-PROG ACCESS OK

### 7.10.2 BFSK

Example:

- BFSK option ON  
Computer Output: 601001 112F 1[14]  
Printer Output: 22-Jun-1998-11:17:26 - Jun 22 1998-11:21:32-01/02-SG-01-123-112-FIRE ALARM
- BFSK option OFF  
Computer Output: 101001 112F 1[14]  
Printer Output: 22-Jun-1998 13:05:17 - Jun 22 1998-13:09:23-01/02-SG-01-123-112-FIRE ALARM

## 7.11 SIA FSK

The SIA digital format is a modem format communicating at 110 or 300 Baud and using the SIA protocol to transfer information to the computer.

The standard DRL2000 can receive Bell 103 modem frequencies.

**NOTE:** *The DRL2000 can accept SIA formats with and without separators. The DRL2000 version 1.4 software implements Levels 1, 2 and 3 of the SIA 1993IIB Digital Communication Standard, but it does not support "Receiver Call out and Access Passcode Block," "Reverse Channel Block," and "V-Channel Communications".*

The DRL2000 supports an account code with a maximum of 16 digits, (including any displayable ASCII characters except the pipe symbol: "|"). It also supports an alarm code with a maximum of 4 digits. Usually, the central station automation refers to the SIA Event Block Data Code Definitions for information on interpreting the alarm codes.

Acknowledgments for the SIA format are tonal by default. The transmitter may, however, request data acknowledgment by transmission of the optional configuration block. When the DRL2000 receives the configuration block from a transmitter requiring data acknowledgment, it will send the tonal acknowledgment to this block. It will then send the data acknowledgment to the following data blocks if the data received is valid.

Example:

- Printer: Jul 20 1998-17:30:16-01/02-SG-01-123-1234 - NM008
- Computer: S011[#1234:NBA08]

## 7.12 Silent Knight FSK1, FSK2

### 7.12.1 Silent Knight FSK1 Protocol

ERRLLLsSSsAAAAAAXXsSSs[DC4]

Where:

E	FSK protocol identifier
RR	Receiver number
LLL	Line number
s	Spaces
AAAAAA	Account number (if the account is 4 or 5 digits, the leading "A"s will be replaced by spaces)
XX	Alarm code

Possible alarm codes are as follows:

00	Alarm Panic
01-08	Alarm 01-08
09	Holdup
10-19	Alarm 10-19
30	Test code
31	Trouble line 1
32	Trouble line 2
33	Expand trouble
34	Forced access
35	Restore line 1
36	Restore line 2
37	Expand restore
38	Cancel code
39	Data lost
40	Closing
41-49	Closing 1-9
50-59	Bypass 10-19
60	Trouble AC
61-68	Trouble 1-8
69	Trouble bat
70	Restore AC
71-78	Restore 1-8
79	Restore bat
80	Access
81-89	Access 1-9
90	Opening
91-99	Opening 1-9
[DC4]	Represents the terminator

Example

- Printer:L1-1234-03-LIBRARY WORD  
HH:MM:SS-DD/MM
- Computer: E01001 123403 [14]

### 7.13 Silent Knight FSK2 Protocol

The DRL2000 will provide two possible outputs to the computer, according to the value set under option A7. When the option is programmed as "02", the computer output will be as follows:

FRRLLLsSSsAAAAAYZZs[DC4]

Where:

F	FSK2 protocol 1 identifier
RR	Receiver number
LLL	Line number
s	Spaces

AAAAAA Account number (if the account is 4 or 5 digits, the leading "A"s will be replaced by spaces)

YY Event code

ZZ Zone/user number

[DC4] Represents the terminator

**Possible events are as follows:**

YT00 Battery Trouble

YR00 Battery Restore

AT00 System Trouble AC

DOZZ Access left open ID ZZ

DFZZ Access forced ID ZZ

DSZZ Access Station ID ZZ

AJ00 System Restore AC

LTOZ Trouble phone line #0Z

Restore phone line 0Z

Expand trouble device ID z

Expand restore device ID z

ETZZ Expand trouble station ID ZZ (ZZ=17-31)

ERZZ Expand restore station ID ZZ (ZZ=17-31)

RP00 Automatic test

RXZZ Manual test zone ZZ

CA Automatic closing

OA Automatic opening

CLZZ Normal closing ID ZZ

OPZZ Normal opening ID ZZ

CFZZ Forced closing ID ZZ

ORZZ Forced opening ID ZZ

Supervised closing ID ZZ

OTZZ Supervised opening ZZ

CG0a Closing area 0a

OG0a Opening area 0a

DRZZ Access granted ID ZZ

**When the option is programmed as "01", the computer output will be as follows:**

CRRLLLssssAAAAAAXYZZss[DC4]

**Where:**

C FSK2 protocol 2 identifier

RR Receiver number

LLL Line number

s Spaces

AAAAAA Account number (if the account is 4 or 5 digits, the leading "A"s will be replaced by spaces)

X Event code

Y Condition code

ZZ Zone/user number

[DC4] Represents the terminator

**Possible events are as follows:**

B600 Battery Trouble

BE00 Battery Restore

C600 System Trouble AC

CE00 System Restore AC

D60z Trouble phone line #0z

DE0z Restore phone line 0z

E60z Expand trouble device ID z

EE0z Expand restore device ID z

E6zz Expand trouble station ID zz (zz=17-31)

EEzz Expand restore station ID zz (zz=17-31)

E100 Automatic test

E2zz Manual test zone ZZ

F000 Automatic closing

F400 Automatic opening

F1zz : Normal closing ID ZZ

F5zz : Normal opening ID ZZ

F2zz : Forced closing ID ZZ

F6zz : Forced opening ID ZZ

F3zz : Supervised closing ID ZZ

F7zz : Supervised opening ZZ

FD0a : Closing area 0a

FF0a : Opening area 0a

F8zz : Access

F9zz : Access left open ID zz

FAzz : Access forced ID ZZ

FBzz : Access station ID ZZ

FC00 : Duress

FE00 : Data lost

## 7.14 SESCOA Super Speed

SESCOA Super Speed is a 40 Baud communication format. Account codes are programmed as 4-digit decimal codes ranging from 0001 to 3374. The account code is followed by a 1-digit event code, a 2-digit alarm code, and 1-digit checksum.

Option [A5] must be programmed as "01" in order to use SESCOA Super Speed decoding instead of 4/2 with checksum decoding.

Example:

- Printer: L01-1234—LOW BATT HH:MM:SS-DD/MM
- Computer: 701007sssss1234sF

## 7.15 DRL2000 Predefined Library Decoding and Event Codes Table

### 7.15.1 3/1 - 4/1 Alarm Library

For Alarm Message	Corresponding Code	Event Code (Options 30-3F)
	0 (A)	A PER TEST REPORT
	1	A FIRE ALARM
	2	A PANIC ALARM
	3	A BURGLARY
	4	A GENERAL ALARM
	5	A GENERAL ALARM
	6	A GENERAL ALARM
	7	A MEDICAL
	8	A SYSTEM TROUBLE
Restore	9	R RESTORE
Open	B	O OPENING
Close	C	C CLOSING
Cancel	D	/ CANCEL
Restore	E	R RESTORE
Trouble	F	T SYSTEM TROUBLE

### 7.15.2 3/1-4/1 Extended, 3/2 & 4/2 Alarm Library

Alarm	0x (Ax)	A	PER TEST REPORT
Alarm	1x	A	FIRE ALARM
Alarm	2x	A	PANIC ALARM
Alarm	3x	A	BURGLARY
Alarm	4x	A	GENERAL ALARM
Alarm	5x	A	GENERAL ALARM
Alarm	6x	A	GENERAL ALARM
Alarm	7x	A	MEDICAL
Alarm	8x	A	SYSTEM TROUBLE
Restr	9x	R	RESOTRE
Open	Bx	O	OPENING
Close	Cx	C	CLOSING
Cancl	Dx	/	CANCEL
Restr	Ex	R	RESTORE
Trble	Fx	T	SYSTEM TROUBLE

### 7.15.3 4/2 Extended & 4/3 Alarm Library

Alarm	0xx(Axx)	T	0	PER TEST REPORT
Alarm	1xx	A	1	FIRE ALARM
Alarm	2xx	A	2	PANIC ALARM
Alarm	3xx	A	3	BURGLARY
Close	4xx	C	4	CLOSING
Open	5xx	O	5	OPENING
Alarm	6xx	T	6	SERVICE
Alarm	7xx	A	7	MEDICAL
Alarm	8xx	A	8	MESSAGE
Restr	9xx	R	9	RESTORE
CloseGrp	Bxx	C	C	OPENING
OpenGrp	Cxx	O	O	CLOSING
Bypas	Dxx	B	B	CANCEL
Unbyp	Exx	H	H	RESTORE
Cancl	Fxx	/	/	SYSTEM TROUBLE

### 7.15.4 Event Codes Summary

Code	Event
0	Automatic Test
1	Fire Alarm
2	Panic Alarm
3	Burglary Alarm
4	Closing by User Number
5	Opening by User Number
6	Service
7	Medical Emergency
8	Message
9	Restore
A	Alarm
B	Bypass
C	Closing
D or /	Cancel
H	Unbypass
O	Opening
R	Restore
T	Trouble
Z	Common Event Code
20 Hex	Common Event code "Space"

Ensure that the central station automation software is able to accept these codes if they are to be used.

## Section 8 - CPM2000 Central Processing Module

The CPM2000 is the central processing module that monitors the DRL2000 Line Cards and forwards the information from the Line Cards to the computer and printer. The CPM2000 is capable of monitoring a maximum of 255 DRL2000 modules.

### 8.1 General Information

The CPM2000 64-bit micro-controller and real-time language program running at 133 MHz allow the system to quickly and efficiently execute several tasks at the same time. The use of a unique menu display system enhances the system's ease of use for the operator and makes the system configuration and programming simple and efficient. Several diagnostics modes are available to assist the operator in troubleshooting and maintenance, the MLR2000 Console software through Windows 9x/2000/XP computer is also available to setup the CPM and Line cards

### 8.2 Features

- Multi-tasking allows the receiver to perform functions that might otherwise be delayed by a slow computer acknowledgement response
- Fast internal communication results in practically no delay in transfer of information between the Line Card and the CPM2000. The CPM2000 is capable of polling more than 200 Line Cards in less than 2 seconds.
- LCD contrast easily adjusted
- Hot switching to secondary CPM2000
- 1/2 floppy drive for data input/ output and software upgrades.

- Ethernet A and B to DRL2000 line-cards
- TCP/IP output to automation software and MLR2000 console software.
- Two RS232 ports for automation software
- 11 input/ outputs for BUZZER, ACT, etc.
- 2 relay outputs
- Available COM1 and COM2 baud rates: 110, 150, 300, 600, 1200, 2400, 4800, 9600, 19200 or 38400
- COM1 or COM2 Data bits: 7, 8 or 9
- COM1 or COM2 Parity: Even, odd or none
- COM 1 or COM2 Stop Bits: fixed at 1
- System menu for easy initial programming.
- Software Version 1.0 supports line-cards and CPM2000 programming through TCP/ IP from a computer

### 8.3 CPM2000 Controls

- [ACK] Button: Used to manually acknowledge an alarm event when a computer is not connected to the receiver. Press the [ACK] button to turn the 'ACK' light OFF and silence the buzzer.

#### 8.3.1 "ACK" light

Flashes when a message is received from the line card and the computer is disconnected.

#### 8.3.2 [Enter] button

Not used.

#### 8.3.3 [Backspace] button

Not used.

#### 8.3.4 [Escape] button

Not used.

Figure 8, CPM2000 Front View

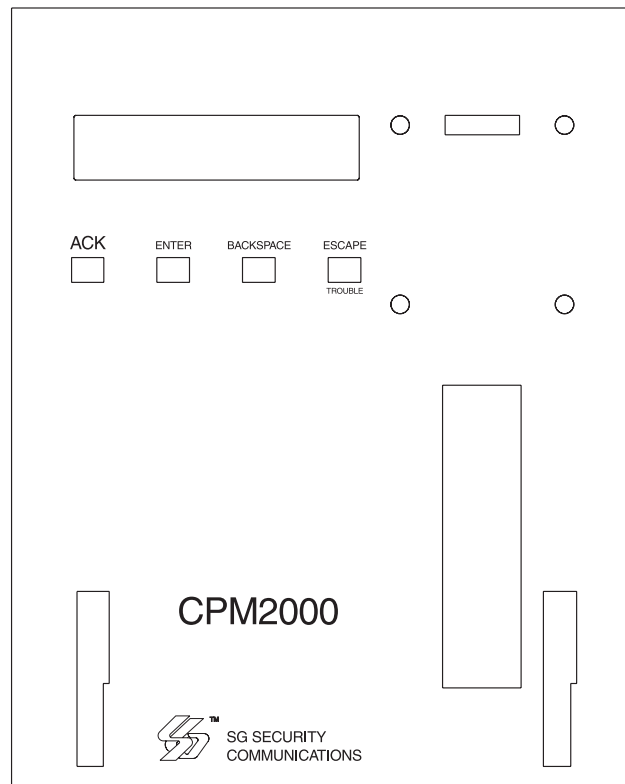

## Section 9 - CPM2000 Wiring Diagram

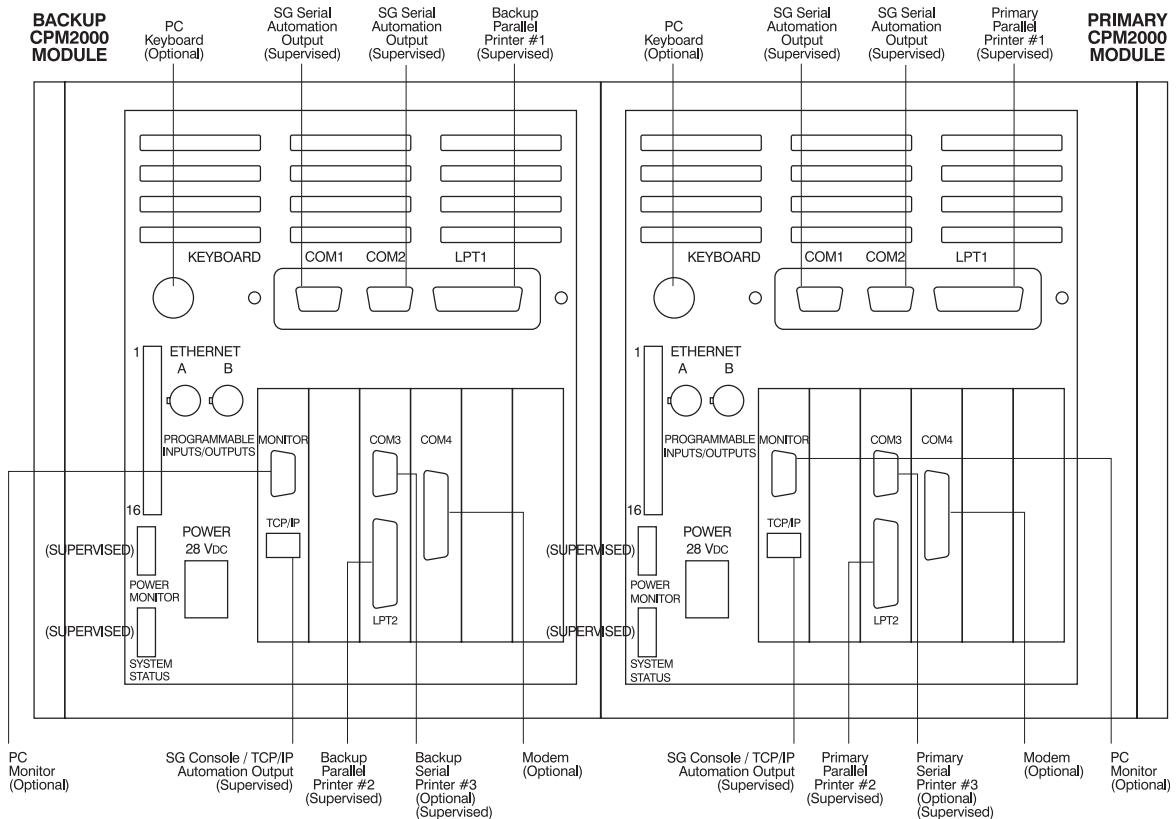

### Programmable Inputs/Outputs

Relay contacts rating: 3 A, 250 VAC  
Non-supervised for connection to power-limited circuits only

- 1 Relay 2 Pin 1
- 2 Relay 2 Pin 2
- 3 Relay 1 Pin 1
- 4 Relay 1 Pin 2
- 5 GND

Outputs switched to negative  
Max. short circuit current 80 mA/12 Vdc  
Limited by 150 ohm/1 W resistors

Non-supervised

- 6 Trouble Output
- 7 ACK Output
- 8 Buzzer Output
- 9 PGMOUT 4
- 10 PGMOUT 3
- 11 PGMOUT 2
- 12 PGMOUT 1

Max. input voltage 12 V, 10 mA  
Input threshold 1.3 V  
Supervised

- 13 PGMIN 4
- 14 PGMIN 3
- 15 PGMIN 2
- 16 PGMIN 1 (Used for fans supervision)

### Notes:

1. PC keyboard and monitor are used only for CPM2000 module configuration
2. SG console is used for software updates on line card
3. All external devices should be installed in the same room as the receiver (within 20 ft.)
4. All circuits are power limited
  - CPU 1150 (Panasonic KX-P1150)
  - SCS-PTR (Okidata Microline 182/184)

### 9.1 Loss of Socket/Automation

It is estimated that sockets may appear and disappear regularly as processes are terminated and reconstituted. After 5 seconds of loss the CPM2000 shifts to the next connection level. The connection level cases are.

As an Example of Source Destination  
the Fall-down case

**Table 1**

Slot 1	CPM A TCP/IP	Automation TCP/IP
Slot 2	CPM A serial 1	Automation serial
Slot 3	END	

Each slot may be populated by a selection. After 5 seconds in a slot not running the CPM2000 will go to the next running resource (i.e. actively polling) until 'END' is encountered. When End is encountered the unit will continuously try to connect to the last entry. One of the switched negative output on the CPM (PGMOUT 1) will be activated when automation fails.

The Manual Restore rule is a command that may be issued on the Sur-Gard console to jump back to the first entry. The CPM and automation must connect to all resources announced all the time. In the CPM's case this means that a socket is presented for each automation to connect to.

### 9.2 CPM Redundancy

CPM's are directly redundant. The secondary CPM constantly monitors the first CPM by observing polling events. If the primary is considered failed either by loss or by agreed upon takeover, the unacknowledged signals on the systems line-cards are flushed out of the failed CPM. As the secondary CPM resumes polling the previously unacknowledged signals are re-transmitted from the line card in chronological order.

### 9.3 CPM Restoral

All contemplated scenarios for recovery of a CPM except watchdog restart involve a serviceman. It is expected that CPM restoral will be manually switched from the console.

## Section 10 - MLR2000 Computer Interface

The CPM2000 is able to send alarm messages to a computer connected to the TCP/IP or serial port. This section describes the communication procedures, and the communication formats available for use.

### 10.1 Virtual connectivity

Each CPM2000 has one IP address and a number of associated ports. Each MLR2000 receiver may have up to two CPM2000's, configured as a primary CPM plus an optional 'hot backup' CPM. Internally, socket programming uses specific ports for expected tasks. The MLR2000 is the 'Server' in a connection-oriented protocol (Berkeley Socket 4.3BSD).

In the case of an IP Fall-down, serial ports will carry the same 'stream' of traffic as TCP/IP, as backup communications channels.

As the CPM does not attempt to save state, when it fails communications are switched to the backup CPM. Line cards will re-transmit unacknowledged packets through the system, restoring any CPM message loss.

### 10.2 Automation Mode

In automation mode it is expected that the primary connection is via TCP/IP networking on the 10BaseT Ethernet connection. To setup this mode a menu will prompt the user for an IP Address. Once the IP address is set up all other options and setups may be done via the Sur-Gard Console Package running on a Windows 9x/2000/XP platform.

The TCP/IP connection is the primary output of the CPM2000 for automation computer alarms. It is estimated that sockets may appear and disappear regularly as processes are terminated and reconstituted. After 5 seconds of socket loss, a socket loss is declared and automation output is shifted to the next connection level, which is the serial automation output connection.

#### 10.2.1 First configuration: LOOP (0)

If both outputs are present, the CPM2000 will send to the TCP/IP until it fails, proceed to the serial until it fails, proceed back to the TCP/IP until it fails ... and so on.

#### 10.2.2 Second configuration: FALL BACK (1)

If both outputs are present, the CPM2000 will send to the TCP/IP until it fails, proceed to the serial until it fails, and will keep trying on the serial continuously, or until the reset fallback command is generated from the console, in which case it would go back to try the TCP/IP connection.

#### 10.2.3 Third Configuration: ALL (2)

The CPM2000 will always send to all connected outputs. If at least one output replies with a ACK, then the alarm is considered as transmitted regardless if the other output acknowledged it or not. This setting is NOT recommended.

#### Flow diagram for Automation LOOP Mode (0)

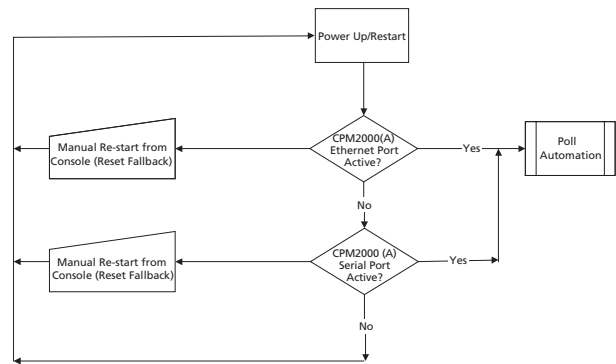

#### Flow diagram for Automation FALL BACK Mode (1)

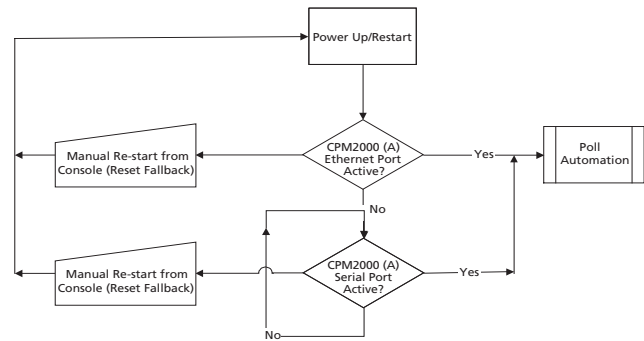

#### Flow diagram for Automation ALL Mode (2)

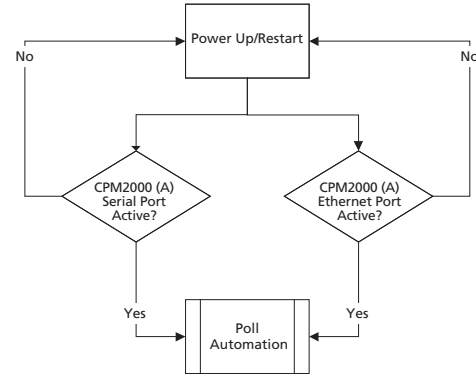

### 10.3 TCP/IP Ports

Each CPM2000 has a user selectable IP address and Port base address which is applied on the next reboot. Originally the unit will be shipped with IP address 10.0.7.00 on both, the primary and the secondary CPM.

Table 2

Base Port #	Port Name	Base +
1024	Sur-Gard Console Port	Base
1025	SG-Automation Port	Base + 1
1026	2nd-Automation Port	Base + 2
1027	Reserved	Base + 3
1028	Reserved	Base + 4
...		...
1034	Reserved	Base + 9

The primary point to be made is that the base port is user configurable as is the IP address.

## 10.4 Client Side Connects

The Automation 'Client' attaches a socket to the CPM 'server' as per the following diagram after Stevens 'UNIX Network Programming' Prentice Hall 1990 section 6.2.

## 10.5 Stream Packet Structure

The stream is an encapsulation of MLR2000 Automation Serial Output.

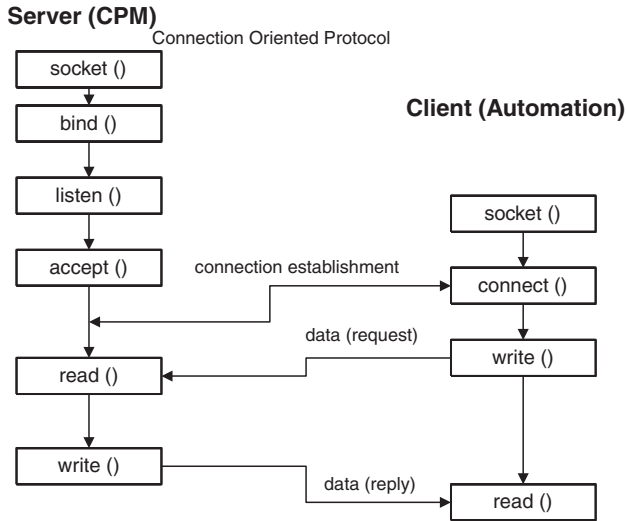

## 10.6 Status Addressing

Line card status will be reported via physical addressing. The line-cards will be assigned by shelf and slot number. All device status information is in Sur-Gard format. The reporting of status on this port, automation output, CPM display and printer will relate to physical addressing. Physical addressing was chosen to facilitate maintenance, error outputs will include the physical address to assist in maintenance.

## 10.7 Overview of Communication

When the CPM2000 receives data from a Line Card, it forwards the data to the automation and awaits an acknowledgment signal from the computer. The CPM2000 also monitors the connection to the computer by sending a supervisory 'heartbeat' signal to every port every 10 seconds. If the 'heartbeat' transmission determines that the computer is off-line or disconnected, a message similar to this will be sent to the printer:

Com Absent! or SG TCP/IP Absent

**NOTE:** The message indicates the time and date that communications through COM1 were determined to be interrupted.

When COM1 communications are re-established, a message similar to this one will be printed:

Com Restored or SG TCP/IP Restored

**NOTE:** The message indicates the time and date that communications through COM were determined to be re-established.

**CPM2000 Internal Status Messages:**

<b>Description</b>	<b>Printer Message</b>	<b>Automation message</b>
24V Battery Low	24V Battery Low	YT0000
24V Battery Restored	24V Battery Restored	YR0000
5V Failure	5V Failure	YT0001
5V Restored	5V Restored	YR0001
Fan Circuit Failure	Fan Circuit Failure	YX0000
Fan Circuit Restored	Fan Circuit Restored	YZ0000
Operator activity mode.	Programming Entered	LB0000
Primary CPM2000 Failure	Primary CPM2000 Failure	YX0001
Printer #1 Error	Printer#1 Error	VZ0001
Printer #1 Restored	Printer#1 Restored	VY0001
Printer #2 Error	Printer#2 Error	VZ0002
Printer #2 Restored	Printer#2 Restored	VY0002
Printer #x Error	Printer#x Error	VZ000x
Printer #x Restored	Printer#x Restored	VY000x
PSU2000 AC Source A Failure	PSU-AC A Fail	AT0000
PSU2000 AC Source A Restored	PSU-AC A Restored	AR0000
PSU2000 AC Source B Failure	PSU-AC B Fail	AT0001
PSU2000 AC Source B Restored	PSU-AC B Restored	AR0001
PSU2000 DC Source A Failure	PSU-DC A Fail	YP0003
PSU2000 DC Source A Restore	PSU-DC A Restore	YR0003
PSU2000 DC Source B Failure	PSU-DC B Fail	YP0004
PSU2000 DC Source B Restore	PSU-DC B Restore	YR0004
Secondary CPM2000 Failure	Secondary CPM2000 Failure	YZ0002
Serial Port #1 not responding.	COM#1 Absent.	YC0001
Serial Port #1 responded ACK	COM#1 Restored	YK0001
Serial Port #2 not responding	COM#2 Absent.	YC0002
Serial Port #2 started polling	COM#2 Restored	YK0002
TCP/IP Printer error	TCP/IP Printer Error	VZ0000
TCP/IP Printer Restored	TCP/IP Printer Restored	VY0000
TCP/IP Socket 1025 Failed	SG -TCP/IP Failed	NT1025
TCP/IP Socket 1025 Restored	SG -TCP/IP Restored	NR1025
UPS AC Fail (PGM)	UPS AC Fail	AT0002
UPS AC Restored	UPS AC Restored	AR0002
UPS Low Battery Restore	UPS Low Battery Restore	YR0002
UPS Low Battery.	UPS Low Battery.	YT0002
Secondary CPM2000 Failure	Secondary CPM2000 Failure	YX0002
Line Fault	Line Fault	LTSStt
Line Restore	Line Restore	LRSStt
Fault Call	Fault Call	YCSStt
Fault Data	Fault Data	YNSStt
Line Card Reset	Line Card Reset	RRSStt
Line Card Restored	Line Card Restored	YESStt
Line Card Absent	Line Card Absent	YDSStt
Primary CPM2000 Reset	Primary CPM2000 Power Up	RR0000
Secondary CPM2000 Reset	Secondary CPM2000 Power Up	RR0001
Line Card Busy(Buffer Full)	Line Card Busy Out	YBSStt
Internal communication error with Line card	Internal Comm Error	YOSStt
Checksum fail on DRL2000 Boot up	Checksum Failed	YFSStt
Internal Communication Error with Computer	Computer Internal Comm Error	NTSSoo

where

SS = Shelf in Hex  
 tt = Slot in Hex  
 XXXX = Socket number

---

**CPM2000 LCD Messages by priority:**

VZ0000:	Parallel port Printer Error
VZ0001:	TCP/IP Printer Error
YC0001:	COM#1 Absent
YC0002:	COM#2 Absent
YT0000:	12V Battery Low
YT0001:	5V Failure
AT0000:	AC CPMA Failure
AT0001:	AC CPMB Failure

**Special Messages:**

S67890[#0000]ABLOCKEDCALL 1234567890][14]  
S01001[#0000]ABLOCKEDCALL 12345 1234567890][14]  
S01001[#0000]AAHS TABLE FULL]

## **10.8 Console Specifies which SG Automation to Supervise**

A selection which defines a combination of SG Sockets, Ports and Protocols may be active. This setup, is saved in the configuration file. Also presented is the selection of ports that may be supervised for the purposes of restorals or fall down.

## Section 11 - PSU2000 Power supply Module

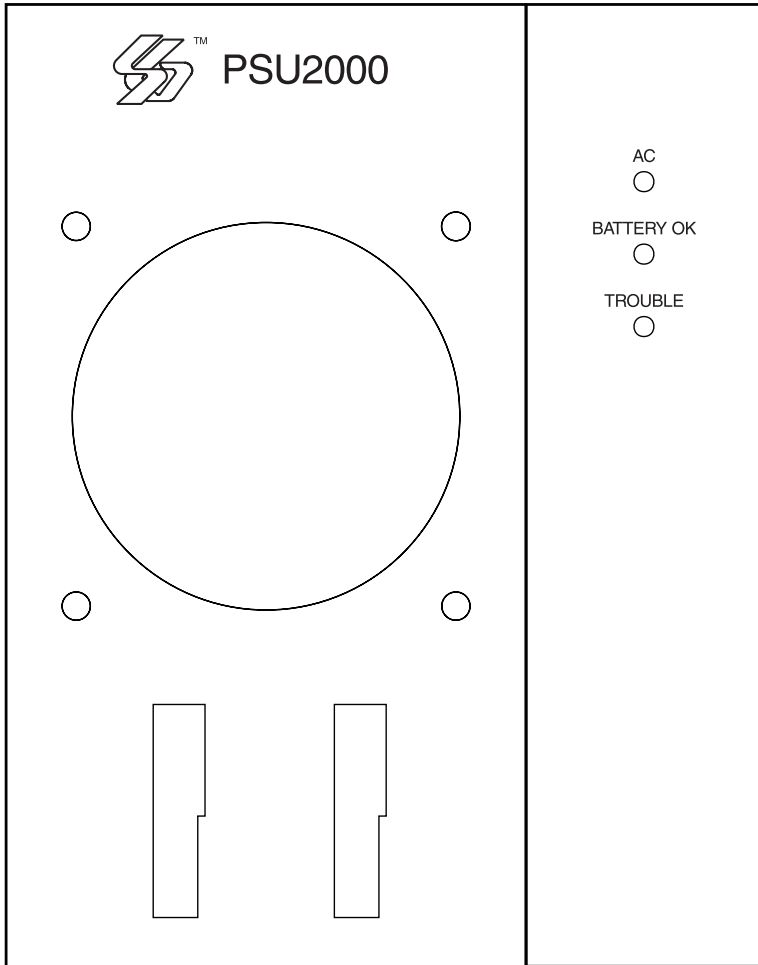

### 'AC' LED

It indicates the presence of AC.

### 'BATTERY OK' LED

It indicates the battery status (ON when battery is charged).

### 'Trouble' LED

It indicates a trouble in the power supply.

---

## **Section 12 - Automation Protocols**

The Sur-Gard MLR2000 receiver sends the various protocols to report signals to the central station computer via an RS232 port. The complete description of protocols is available upon request.

### **12.1 Data Byte protocol**

The Sur-Gard MLR2000 receiver uses a default configuration of 9600 Baud, one start bit, 8 data bits, no parity bit, and one stop bit structure to transmit and receive signals on the RS-232 port. This protocol can be programmed on the receiver to enable different configurations.

### **12.2 Acknowledgment of the Signal**

The Sur-Gard receiver requires an acknowledgment signal [ACK] (Hex 06) from the computer software within 4 seconds for each message sent. Failure to receive the [ACK] will result in the retransmission of the same signal three times before giving up. The same thing happens if the receiver receives a [NAK] (hex 15). In case of communication failure with the computer, the Sur-Gard receiver can store up to 127 times the number of lines installed in its internal memory. The communication is resumed when the first ACK is received on the heartbeat.

---

## Section 13 - Detailed Description of Computers

### 13.1 COM Responses

When the CPM2000 sends an event to the computer, it checks for 3 responses: Ack, Nack or Unknown/No Response

An ACK tells the CPM2000 the computer got the event successfully. A NACK tells the CPM2000 the computer got the message but didn't understand it. The CPM will attempt to send the message 20 times. If after 20 attempts it continually got NACK from the computer, the CPM and line card will send a communication error event to the printer, and then begin attempting to send the next event in the Line card buffer to the computer. Any other response from the computer, including no response will cause the CPM to attempt to send the message again, up to 4 attempts. If after 4 attempts the CPM got no response or an unknown response, it will assume nothing is connected and generate an alarm.

### 13.2 Automation Absent

When the computer is not responding to transmissions, the CPM will generate a 'COMx Absent' or 'TCP/IP Absent' trouble. When a trouble occurs, the CPM will continue to attempt to send a signal to the computer until it gets a response.

The CPM2000 will use the heartbeat signal to poll automation for a response. It will make 4 attempts, then wait the next Heartbeat time before making another 4 attempts. The typical heartbeat interval is 30 seconds.

Supervisory Heartbeat Signal Protocol (1):

1RR000ssssssssss@ssss[DC4]

RR: Receiver number (Real programmed number. Never virtual).

s: Space Character.

@: Supervisory Signal.

[DC4]: Terminator, 14 Hex.

This signal is used to supervise the communication between the receiver and the computer. It is sent to the computer about every 30 seconds and is programmable from the receiver. The computer should acknowledge this signal with an [ACK].

The CPM can be programmed to send a test signal to the computer once every 01-99 seconds to test the connection between the CPM and the computer (30 seconds is recommended). If a heartbeat fails to get a response from the computer, the CPM will immediately transmit the heartbeat again, up to 4 attempts.

If all automation outputs failed, the CPM will start the manual mode operation. (See manual mode). If the line-cards buffers are full, the line-cards will stop answering the calls.

## Appendix A - DRL2000 Communication Formats

NAME	HANDSHAKE	DATA	BAUD	FORMAT	EXTENDED	KISS OFF
Ademco Express	Dual Tone	DTMF	DTMF	4/1(oprion),4/2	NO	1400Hz
Ademco Slow	1400Hz	1900Hz	10bps	3/1,4/1(or 3/2),4/2	NO	1400Hz
Ademco Slow	1400Hz	1900Hz	10bps	4/2,4/1,3/1	YES	1400Hz
ADT Focus *	-	-	-	-	-	-
ADT Multi-point II *	-	-	-	-	-	-
ADT SIA *	-	-	-	-	-	-
Contact ID	Dual Tone	DTMF	DTMF	10/2/1/3/2	NO	1400Hz
Contact ID	Dual Tone	DTMF	DTMF	4/2/1/3/2/3	NO	1400Hz
FBI Super Fast	2300Hz	DTMF	DTMF	4/3/1	NO	2300Hz
Franklin	2300Hz	1800Hz	20bps	3/1,4/1(or 3/2),4/2	NO	2300Hz
Franklin	2300Hz	1800Hz	20bps	4/2,4/1,3/1	YES	2300Hz
ITI	ITI	FSK	110/300	-	NO	ITI
Modem II	Modem II	FSK	110	FSK	NO	Modem II
Modem IIE	Modem IIE	FSK	300	FSK	NO	Modem IIE
Modem IIIa <sup>2</sup>	Modem II	FSK	300	FSK	NO	Modem IIIa <sup>2</sup>
Radionics	2300Hz	1800Hz	40bps	3/1,4/2	NO	2300Hz
Radionics	2300Hz	1800Hz	40bps	4/2,3/1	YES	2300Hz
Radionics	2300Hz	1800Hz	40bps	3/1+parity 4/2+parity	NO	2300Hz
Radionics	2300Hz	1800Hz	40bps	3/1+parity	YES 4/2+parity	2300Hz
RadionicsBFSK	1400Hz	FSK	42	3/2	NO	1400Hz
RadionicsBFSK	2300Hz	FSK	42	3/2	NO	2300Hz
Sescoa S. Speed	2300Hz	1800Hz	40bps	4/3+Checksum	NO	2300Hz
S.F. Ademco	Dual Tone	DTMF	DTMF	4/8/1	NO	1400Hz
S.F. Ademco	Dual Tone	DTMF	DTMF	4/8/1 + Checksum	NO	1400Hz
SIA FSK Level 1, 2, and 3.	SIA -	FSK mark Space	110 bps/ 300 bps	Tonal data, ACK -	- -	--
Silent Knight Fast	1400Hz	1900Hz	14bps	3/1,4/1(or 3/2),4/2	NO	1400Hz
Silent Knight Fast	1400Hz	1900Hz	14bps	4/2,4/1,3/1	YES	1400Hz
Silent Knight FSK0	1400Hz	FSK	110	4/1	NO	1400Hz
Silent Knight FSK1	1400Hz	FSK	110	4/1	NO	1400Hz
Silent Knight FSK2	1400Hz	FSK	110	4/2	NO	1400Hz
Sur-Gard	2300Hz	DTMF	DTMF	4/1,4/2,4/3	NO	2300Hz
Sur-Gard	2300Hz	DTMF	DTMF	4/3+Checksum	NO	2300Hz
Sur-Gard	Dual Tone	DTMF	DTMF	4/1,4/2,4/3	NO	1400Hz
Sur-Gard	Dual Tone	DTMF	DTMF	4/3+Checksum	NO	1400Hz
WESTEC *	DTMF					
Contact ID Safety net *	Serial					
SF Ademco safety net	Serial					
DMP Serial 1	DMP	FSK	110	DMP	NO	DMP
DMP Serial 3	DMP	FSK	110	DMP	NO	DMP
Varitech	2300Hz	FSK	110	4/1, 4/2	NO	2300Hz
Adcor	2300Hz	Pulse	Pulse	3/1, 3/2	NO	2300Hz

\* Not available on the standard version.

## Appendix B - Decimal - HEX - Binary Conversion Chart

DEC	HEX	Binary	DEC	HEX	Binary	DEC	HEX	Binary	DEC	HEX	Binary
000	00	0000 0000	064	40	0100 0000	128	80	0100 0000	192	C0	0100 0000
001	01	0000 0001	065	41	0100 0001	129	81	0100 0001	193	C1	0100 0001
002	02	0000 0010	066	42	0100 0010	130	82	0100 0010	194	C2	0100 0010
003	03	0000 0011	067	43	0100 0011	131	83	0100 0011	195	C3	0100 0011
004	04	0000 0100	068	44	0100 0100	132	84	0100 0100	196	C4	0100 0100
005	05	0000 0101	069	45	0100 0101	133	85	0100 0101	197	C5	0100 0101
006	06	0000 0110	070	46	0100 0110	134	86	0100 0110	198	C6	0100 0110
007	07	0000 0111	071	47	0100 0111	135	87	0100 0111	199	C7	0100 0111
008	08	0000 1000	072	48	0100 1000	136	88	0100 1000	200	C8	0100 1000
009	09	0000 1001	073	49	0100 1001	137	89	0100 1001	201	C9	0100 1001
010	0A	0000 1010	074	4A	0100 1010	138	8A	0100 1010	202	CA	0100 1010
011	0B	0000 1011	075	4B	0100 1011	139	8B	0100 1011	203	CB	0100 1011
012	0C	0000 1100	076	4C	0100 1100	140	8C	0100 1100	204	CC	0100 1100
013	0D	0000 1101	077	4D	0100 1101	141	8D	0100 1101	205	CD	0100 1101
014	0E	0000 1110	078	4E	0100 1110	142	8E	0100 1110	206	CE	0100 1110
015	0F	0000 1111	079	4F	0100 1111	143	8F	0100 1111	207	CF	0100 1111
016	10	0001 0000	080	50	0101 0000	144	90	0101 0000	208	D0	0101 0000
017	11	0001 0001	081	51	0101 0001	145	91	0101 0001	209	D1	0101 0001
018	12	0001 0010	082	52	0101 0010	146	92	0101 0010	210	D2	0101 0010
019	13	0001 0011	083	53	0101 0011	147	93	0101 0011	211	D3	0101 0011
020	14	0001 0100	084	54	0101 0100	148	94	0101 0100	212	D4	0101 0100
021	15	0001 0101	085	55	0101 0101	149	95	0101 0101	213	D5	0101 0101
022	16	0001 0110	0860	56	0101 0110	150	96	0101 0110	214	D6	0101 0110
023	17	0001 0111	87	57	0101 0111	151	97	0101 0111	215	D7	0101 0111
024	18	0001 1000	088	58	0101 1000	152	98	0101 1000	216	D8	0101 1000
025	19	0001 1001	089	59	0101 1001	153	99	0101 1001	217	D9	0101 1001
026	1A	0001 1010	090	5A	0101 1010	154	9A	0101 1010	218	DA	0101 1010
027	1B	0001 1011	091	5B	0101 1011	155	9B	0101 1011	219	DB	0101 1011
028	1C	0001 1100	092	5C	0101 1100	156	9C	0101 1100	220	DC	0101 1100
029	1D	0001 1101	093	5D	0101 1101	157	9D	0101 1101	221	DD	0101 1101
030	1E	0001 1110	094	5E	0101 1110	158	9E	0101 1110	222	DE	0101 1110
031	1F	0001 1111	095	5F	0101 1111	159	9F	0101 1111	223	DF	0101 1111
032	20	0010 0000	096	60	0110 0000	160	A0	0110 0000	224	E0	0110 0000
033	21	0010 0001	097	61	0110 0001	161	A1	0110 0001	225	E1	0110 0001
034	22	0010 0010	098	62	0110 0010	162	A2	0110 0010	226	E2	0110 0010
035	23	0010 0011	099	63	0110 0011	163	A3	0110 0011	227	E3	0110 0011
036	24	0010 0100	100	64	0110 0100	164	A4	0110 0100	228	E4	0110 0100
037	25	0010 0101	101	65	0110 0101	165	A5	0110 0101	229	E5	0110 0101
038	26	0010 0110	102	66	0110 0110	166	A6	0110 0110	230	E6	0110 0110
039	27	0010 0111	103	67	0110 0111	167	A7	0110 0111	231	E7	0110 0111
040	28	0010 1000	104	68	0110 1000	168	A8	0110 1000	232	E8	0110 1000
041	29	0010 1001	105	69	0110 1001	169	A9	0110 1001	233	E9	0110 1001
042	2A	0010 1010	106	6A	0110 1010	170	AA	0110 1010	234	EA	0110 1010
043	2B	0010 1011	107	6B	0110 1011	171	AB	0110 1011	235	EB	0110 1011
044	2C	0010 1100	108	6C	0110 1100	172	AC	0110 1100	236	EC	0110 1100
045	2D	0010 1101	109	6D	0110 1101	173	AD	0110 1101	237	ED	0110 1101
046	2E	0010 1110	110	6E	0110 1110	174	AE	0110 1110	238	EE	0110 1110
047	2F	0010 1111	111	6F	0110 1111	175	AF	0110 1111	239	EF	0110 1111
048	30	0011 0000	112	70	0111 0000	176	B0	0111 0000	240	F0	0111 0000
049	31	0011 0001	113	71	0111 0001	177	B1	0111 0001	241	F1	0111 0001
050	32	0011 0010	114	72	0111 0010	178	B2	0111 0010	242	F2	0111 0010
051	33	0011 0011	115	73	0111 0011	179	B3	0111 0011	243	F3	0111 0011
052	34	0011 0100	116	74	0111 0100	180	B4	0111 0100	244	F4	0111 0100
053	35	0011 0101	117	75	0111 0101	181	B5	0111 0101	245	F5	0111 0101
054	36	0011 0110	118	76	0111 0110	182	B6	0111 0110	246	F6	0111 0110
055	37	0011 0111	119	77	0111 0111	183	B7	0111 0111	247	F7	0111 0111
056	38	0011 1000	120	78	0111 1000	184	B8	0111 1000	248	F8	0111 1000
057	39	0011 1001	121	79	0111 1001	185	B9	0111 1001	249	F9	0111 1001
058	3A	0011 1010	122	7A	0111 1010	186	BA	0111 1010	250	FA	0111 1010
059	3B	0011 1011	123	7B	0111 1011	187	BB	0111 1011	251	FB	0111 1011
060	3C	0011 1100	124	7C	0111 1100	188	BC	0111 1100	252	FC	0111 1100
061	3D	0011 1101	125	7D	0111 1101	189	BD	0111 1101	253	FD	0111 1101
062	3E	0011 1110	126	7E	0111 1110	190	BE	0111 1110	254	FE	0111 1110
063	3F	0011 1111	127	7F	0111 1111	191	BF	0111 1111	255	FF	0111 1111

## Appendix C - ASCII Character Chart

Corresponding ASCII with library on printer (Option 70)	HEX Character
20	Space
30	0
31	1
32	2
33	3
34	4
35	5
36	6
37	7
38	8
39	9
41	A
42	B
43	C
44	D
45	E
46	F
47	G
48	H
49	I
4A	J
4B	K
4C	L
4D	M
4E	N
4F	O
50	P
51	Q
52	R
53	S
54	T
55	U
56	V
57	W
58	X
59	Y
5A	Z
5C	\

## Appendix D - Printer Words: Options [60-6F]

The English Printer Library is provided and can be selected by programming the event codes to the corresponding word.  
Words available:

Hex #	Printer Words
00	MEDICAL
01	PENDANT TRANSMITTER
02	FAIL TO REPORT IN
03	RESERVED
04	RESERVED
05	RESERVED
06	RESERVED
07	RESERVED
08	RESERVED
09	RESERVED
0A	FIRE ALARM
0B	SMOKE
0C	COMBUSTION
0D	WATER FLOW
0E	HEAT
0F	PULL STATION
10	DUCT
11	FLAME
12	NEAR ALARM
13	RESERVED
14	PANIC ALARM
15	DURESS
16	SILENT
17	AUDIBLE
18	POLICE
19	DURESS
1A	RESERVED
1B	RESERVED
1C	RESERVED
1D	RESERVED
1E	BURGLARY
1F	PERIMETER
20	INTERIOR
21	24 HOUR
22	ENTRY/EXIT
23	DAY/NIGHT
24	OUTDOOR
25	TAMPER
26	NEAR BURGLARY ALARM
27	SILENT BURG ALARM
28	GENERAL ALARM
29	POLLING LOOP OPEN
2A	POLLING LOOP SHORT
2B	EXPANSION MODULE FAILURE
2C	SENSOR TAMPER
2D	EXPANSION MODULE TAMPER
2E	SILENT ALARM
2F	AUXILIARY
30	NO ACTIVITY
31	DOOR FORCED
32	24 HOUR NON-BURGLARY
33	GAS DETECTED
34	REFRIGERATION
35	LOSS OF HEAT
36	WATER LEAKAGE
37	FOIL BREAK
38	LOW BOTTLED GAS LEVEL
39	HIGH TEMPERATURE
3A	LOW TEMPERATURE
3B	DAY TROUBLE
3C	LOSS OF AIR FLOW
3D	EXPLOSIVE GAS
3E	CARBON MONOXIDE
3F	FAIL TO CHECK IN _ GUARD'S TOUR
40	FREEZE ALARM
41	SPRINKLER
42	LATCHKEY
43	DOOR LEFT OPEN
44	RESERVED
45	RESERVED

Hex #	Printer Words
46	FIRE SUPERVISORY
47	LOW WATER PRESSURE
48	LOW CO2
49	GATE VALVE SENSOR
4A	LOW WATER LEVEL
4B	PUMP ACTIVATED
4C	PUMP FAILURE
4D	ENVIRONMENTAL
4E	EMERGENCY
4F	FOIL ALRM
50	SYSTEM TROUBLE
51	AC LOSS
52	LOW SYSTEM BATTERY
53	RAM CHECKSUM BAD
54	ROM CHECKSUM BAD
55	SYSTEM RESET
56	PANEL PROGRAM CHANGED
57	SELF-TEST FAILURE
58	SYSTEM SHUTDOWN
59	BATTERY TEST FAILURE
5A	GROUND FAULT
5B	REPEATER TAMPER
5C	RF RECEIVER TAMPER
5D	RESERVED
5E	RESERVED
5F	RESERVED
60	RESERVED
61	RESTORE ALARM
62	OPENING ALARM
63	CLOSING ALARM
64	SOUNDER/RELAY
65	BELL 1
66	BELL 2
67	ALARM RELAY
68	TROUBLE RELAY
69	REVERSING
6A	RESERVED
6B	RESERVED
6C	RESERVED
6D	RESERVED
6E	SYSTEM PERIPHERAL
6F	POLLING LOOP OPEN
70	POLLING LOOP SHORT
71	EXPANSION MODULE FAILURE
72	REPEATER FAILURE
73	LOCAL PRINTER PAPER OUT
74	LOCAL PRINTER FAILURE
75	EXPANSION MODULE DC LOSS
76	EXPANSION MODULE LOW BATTERY
77	EXPANSION MODULE RESET
78	COMMUNICATION
79	TELCO 1 FAULT
7A	TELCO 2 FAULT
7B	LONG RANGE RADIO
7C	FAIL TO COMMUNICATE
7D	LOSS OF RADIO SUPERVISION
7E	LOSS OF CENTRAL POLLING
7F	USER TX USWR
80	LOW RECEIVED SIGNAL STRENGTH
81	RESERVED
82	PROTECTION LOOP
83	PROTECTION LOOP OPEN
84	PROTECTION LOOP SHORT
85	FIRE TROUBLE
86	EXIT ALARM
87	LOSS OF RADIO SUPERVISION
88	SENSOR TROUBLE
89	LOSS OF SUPERVISORY - RF
9A	LOSS OF SUPERVISORY - RPM
9B	SENSOR TAMPER

Hex #	Printer Words
9C	RF TRANSMITTER. LOW BATTERY
9D	SMOKE HI-SENSOR
9E	SMOKE LOW-SENSOR
9F	INTRUSION HI-SENSOR
A0	INTRUSION LOW-SENSOR
A1	SELF TEST FAIL
A2	OPEN/CLOSE
A3	O/C BY USER
A4	GROUP O/C
A5	AUTOMATIC O/C
A6	KEYSWITCH O/C
A7	DEFERRED O/C
A8	CANCEL
A9	REMOTE ARM/DISARM
AA	QUICK ARM
AB	RESERVED
AC	CALLBACK REQUEST MADE
AD	SUCCESSFUL DOWNLOAD ACCESS
AE	UNSUCCESSFUL ACCESS
AF	SYSTEM SHUTDOWN
B0	DIALER SHUTDOWN
B1	RESERVED
B2	RESERVED
B3	RESERVED
B4	RESERVED
B5	RESERVED
B6	ACCESS DENIED
B7	ACCESS REPORT BY USER
B8	RESERVED
B9	RESERVED
BA	RESERVED
BB	RESERVED
BC	RESERVED
BD	RESERVED
BE	GROUP CLOSING
BF	GROUP OPENING
C0	ARMED STAY
C1	O/C EXCEPTION
C2	EARLY O/C
C3	LATE O/C
C4	FAIL TO O/C
C5	AUTO ARM FAIL
C6	O/C PARTIAL ARMED
C7	EXIT ERROR
C8	USER PRESENT
C9	RECENT CLOSE
CA	SOUNDER/RELAY DISABLED
CB	BELL 1 DISABLE

Hex #	Printer Words
CC	BELL 2 DISABLE
CD	ALARM RELAY DISABLE
CE	TROUBLE RELAY DISABLE
CF	REVERSING RELAY DISABLE
D0	RESERVED
D1	RESERVED
D2	RESERVED
D3	RESERVED
D4	DIALER DISABLED
D5	RADIO TRANSMITTER DISABLED
D6	MESSAGE ALARM
D7	SERVICE ALARM
D8	RESERVED
D9	RESERVED
DA	RESERVED
DB	RESERVED
DC	RESERVED
DD	RESERVED
DE	ZONE BYPASS
DF	FIRE BYPASS
E0	24 HOUR ZONE BYPASS
E1	BURGLARY BYPASS
E2	GROUP BYPASS
E3	SWINGER BYPASS
E4	UNBYPASS ALARM
E5	RESERVED
E6	RESERVED
E7	RESERVED
E8	MANUAL TRIGGER TEST
E9	PERIODIC TEST REPORT
EA	PERIODIC RF TRANSMISSION
EB	FIRE TEST
EC	STATUS REPORT TO FOLLOW
ED	LISTEN-IN TO FOLLOW
EE	WALK TEST MODE
EF	OFF NORMAL CONDITION
F0	VIDEO TRANSMITTER ACTIVE
F1	RESERVED
F2	EVENT LOG OVERFLOW
F3	TIME/DATE RESET
F4	TIME/DATE INACCURATE
F5	PROGRAM MODE ENTRY
F6	PROGRAM MODE EXIT
F7	EXCEPTION SCHEDULE CHANGE
F8	EVENT LOG 50% FULL
F9	EVENT LOG 90% FULL
FA	EVENT LOG RESET
FB	SCHEDULE CHANGE

## Appendix E - Panels Compatibility List

Panel	Formats	Passed/Failed
Acron Avenger 4000	20 BPS	Not Verified
	Acron Superfast	Not Verified
Adcor PPD-3		Not Verified
ADT Safewatch Pro 3000	Ademco Contact ID	Passed
Ademco Vista	10 BPS	Passed
	DTMF	Passed
Ademco Vista 10SE	10 BPS	Passed
	20 BPS	Passed
	Any DTMF Format	Passed
Ademco Vista 20	Ademco Contact ID	Passed
ADT Focus 7604-030	10 BPS	Passed
	15 BPS	Passed
	20 BPS	Passed
	40 BPS	Passed
Apex 2100E	10 BPS	Passed
	15 BPS	Passed
	20 BPS	Passed
	40 BPS	Passed
Apex Advantage	10 BPS Silent Knight	Passed
	10 BPS Radionics	Passed
	Ademco Contact ID	Passed
Apex System E	10 BPS	Passed
	15 BPS	Passed
	20 BPS	Passed
	Ademco Contact ID	Passed
Aritech-Moose Advisor	Any DTMF Format	Not Verified
	SIA	Not Verified
Aritech-Moose Discovery 1000	10 BPS	Passed
	15 BPS	Passed
	20 BPS	Passed
	40 BPS	Passed
	BFSK	Passed
	Modem II	Passed
Aritech-Moose Z900	10 BPS	Passed
	10 BPS Sescoa	Passed
	15 BPS	Passed
	20 BPS Sescoa	Passed
	20 BPS	Passed
	40 BPS	Passed
	BFSK	Passed
Aritech Moose Z1100-1	10 BPS Silent Knight	Not Verified
	14 BPS Silent Knight	Not Verified
	20 BPS Franklin	Not Verified
	40 BPS Radionics	Not Verified
Aritech-Moose Z1100-E	10 BPS	Passed
	10 BPS Sescoa	Passed
	15 BPS	Passed
	20 BPS	Passed
	20 BPS Sescoa	Passed
	40 BPS	Passed
	BFSK	Passed
AT&T System 8300	10 BPS	Passed
	20 BPS	Passed
	Ademco High Speed	Passed
	SIA	Passed

Panel	Formats	Passed/Failed
C&K System 236	10 BPS	Passed
	20 BPS	Passed
	Any DTMF Format	Passed
C&K System 238	10 BPS	Passed
	20 BPS	Passed
	40 BPS	Passed
	DTMF	Passed
CADDX Ranger 8980E	20 BPS	Passed
	40 BPS	Passed
	Any DTMF Format	Passed
	SIA	Passed
CADDX Ranger 9000E	10 BPS	Not Verified
	20 BPS	Not Verified
	40 BPS (Radionics)	Not Verified
	DTMF	Not Verified
	SIA	Not Verified
DMP 1512/105		Not Supported
DMP 1812	DMP	Passed
DMP 1912XR/114	Ademco Contact ID	Not Verified
	DMP	Not Verified
DMP XR5/103	40 BPS	Passed
	Ademco Contact ID	Passed
	DMP	Passed
DMP XR10/106	40 BPS	Passed
	DMP	Passed
	Ademco Contact ID	Passed
DMP X20	40 BPS	Passed
	DMP	Passed
	Modem IIE	Passed
DMP XR200/101	Ademco Contact ID	Not Verified
	Modem II	Not Verified
	Modem IIE	Not Verified
DMP XR200/104	20 BPS	Not Verified
	Ademco Contact ID	Not Verified
	Modem IIE	Not Verified
DSC NT9005	10 BPS	Passed
	20 BPS	Passed
	Ademco Contact ID	Passed
	SIA	Passed
DSC NT9010	20 BPS	Passed
	Ademco Contact ID	Passed
	SIA	Passed
DSC PC580	20 BPS	Passed
	Ademco Contact ID	Passed
	SIA	Passed
DSC PC1000	10 BPS	Passed
	20 BPS	Passed
DSC PC1500	10 BPS	Passed
	20 BPS	Passed
DSC PC1550	10 BPS	Passed
	20 BPS	Passed
	40 BPS	Passed
DSC PC1555	20 BPS	Passed
	Ademco Contact ID	Passed
	SIA	Passed
DSC PC1575	20 BPS	Passed

Panel	Formats	Passed/Failed
	Ademco Contact ID	Passed
	SIA	Passed
DSC PC2500	10 BPS	Passed
	20 BPS	Passed
	40 BPS	Passed
DSC PC2525	10 BPS	Passed
	20 BPS	Passed
	40 BPS	Passed
DSC PC2550	10 BPS	Passed
	20 BPS	Passed
	40 BPS	Passed
DSC PC3000	10 BPS	Passed
	20 BPS	Passed
	40 BPS	Passed
DSC PC4000	10 BPS	Passed
	20 BPS	Passed
	40 BPS	Passed
	Any DTMF Format	Passed
	SIA	Passed
DSC PC4010 V1X	10 BPS	Passed
	20 BPS	Passed
	40 BPS	Passed
	Any DTMF Format	Passed
	SIA	Passed
DSC PC4010 V2.X	10 BPS	Passed
	20 BPS	Passed
	40 BPS	Passed
	Any DTMF Format	Passed
	SIA	Passed
DSC PC4010 V3.X	20 BPS	Passed
	Ademco Contact ID	Passed
	SIA	Passed
DSC PC4020 V1.X	10 BPS	Passed
	20 BPS	Passed
	40 BPS	Passed
	Any DTMF Format	Passed
	SIA	Passed
DSC PC4020 V2.X	10 BPS	Passed
	20 BPS	Passed
	40 BPS	Passed
	Any DTMF Format	Passed
	SIA	Passed
DSC PC4020 V3.X	10 BPS	Passed
	20 BPS	Passed
	Ademco Contact ID	Passed
	SIA	Passed
DSC PC4020KT V1.X	10 BPS	Passed
	20 BPS	Passed
	40 BPS	Passed
	Any DTMF Format	Passed
	SIA	Passed
DSC PC40X0 V3.12Y	10 BPS	Passed
	20 BPS	Passed
	SIA	Passed
DSC PC5008 V2.3A	20 BPS	Passed
	Ademco Contact ID	Passed
	SIA	Passed
DSC PC5010 V1.X	20 BPS	Passed

Panel	Formats	Passed/Failed
	Ademco Contact ID	Passed
	SIA	Passed
DSC PC5010 V2.X	20 BPS	Passed
	Ademco Contact ID	Passed
	SIA	Passed
DSC WSS 5010 V2.1	SIA	Passed
DSC PC5015 V2.20	10 BPS	Passed
	20 BPS	Passed
	Ademco Contact ID	Passed
	SIA	Passed
DSC PC5016 V1.0	20 BPS	Passed
	Ademco Contact ID	Passed
	SIA	Passed
DSC PC5020 V3.20	10 BPS	Passed
	20 BPS	Passed
	Ademco Contact ID	Passed
	SIA	Passed
DSC PC6010 V2.10	Ademco Contact ID	Passed
	SIA	Passed
DSC PC8400	10 BPS	Passed
	20 BPS	Passed
	40 BPS	Passed
	Sur-Gard 4/3	Passed
DSC SN4030 V2.0Y	SIA	Passed
DSC SN4030 V3.0Y	SIA	Passed
DSC WLS-900	10 BPS	Passed
	20 BPS	Passed
	40 BPS	Passed
DTI DSS 665	20 BPS	Not Verified
	40 BPS	Not Verified
	SIA	Not Supported
Electronics Line Summit 3208	10 BPS	Not Supported
	20 BPS	Not Supported
	Ademco Contact ID	Fair
	Scantronics	Not Recommended
	SIA	Fair
FBI XL4600	10 BPS	Passed
	40 BPS	Passed
FBI XL4612	10 BPS	Passed
	20 BPS	Passed
	40 BPS	Passed
	FBI Superfast	Passed
ITI Caretaker +	10 BPS	Passed
	20 BPS	Passed
	ITI FSK	Passed
ITI Caretaker	ITI FSK	Not Verified
ITI Commander 2000	20 BPS	Passed
	ITI FSK	Passed
ITI Commander 3000	20 BPS	Passed
	ITI FSK	Passed
ITI Concord	Ademco Contact ID	Passed
	ITI FSK	Passed
ITI Concord Express	Ademco Contact ID	Not Verified
	SIA	Not Verified
ITI Pro 3000	ITI FSK	Not Verified
ITI Pro 4000	ITI FSK	Not Verified
ITI Simon	ITI FSK	Not Verified

Panel	Formats	Passed/Failed
ITI SX-IVB	ITI FSK	Not Verified
ITI SX-V	ITI FSK	Passed
ITI SX-V Special	ITI FSK	Passed
ITI RF Commander	ITI FSK	Passed
ITI Ultragard / Pro 5000	20 BPS	Passed
	ITI FSK	Passed
ITI Fonesafe	ITI FSK	Not Supported
Microtech Galaxy 500	DTMF	Passed
	SIA Level 1	Passed
	SIA Level 2	Passed
	SIA Level 3	Passed
Napco 1016E	10 BPS	Passed
	15 BPS	Passed
	20 BPS	Passed
	40 BPS	Passed
Napco 2600	10 BPS	Passed
	20 BPS	Passed
	40 BPS	Passed
	BFSK	Passed
Napco 3000	10 BPS Silent Knight	Not Verified
	20 BPS Franklin	Not Verified
	40 BPS Radionics	Not Verified
	BFSK	Not Verified
	DTMF	Not Verified
	Modem II	Not Verified
	SIA	Not Verified
Napco GEM-P1632	10 BPS	Passed
	20 BPS	Passed
	Ademco Contact ID	Passed
	SIA	Passed
Optex-Morse Gensys 824	10 BPS	Passed
	20 BPS	Passed
	SIA	Passed
Optex-Morse MDC-16C	10 BPS	Passed
	20 BPS	Passed
	40 BPS	Passed
	BFSK	Passed
	Varitech	Passed
Paradox Digiplex	10 BPS	Passed
	20 BPS	Passed
	Ademco H.S.	Passed
	SIA	Not Verified
Radionics D2071A	40 BPS	Not Verified
	BFSK	Not Verified
Radionics D2112	20 BPS	Passed
	Modem II	Passed
Radionics D2212	20 BPS	Passed
	Modem IIE	Passed
Radionics D4012	40 BPS	Passed
Radionics D4112	10 BPS	Passed
	20 BPS	Passed
	40 BPS	Passed
	BFSK	Passed
	Modem IIA	Passed
Radionics D6112	10 BPS	Passed
	20 BPS	Passed
	40 BPS	Passed
	BFSK	Passed

Panel	Formats	Passed/Failed
	Modem IIA	Passed
Radionics D7112	BFSK	Passed
	Modem IIA	Passed
Radionics D7212	BFSK	Passed
	Modem IIE	Passed
Radionics D7412		Not Verified
Radionics D8112G2	10 BPS	Passed
	20 BPS	Passed
	40 BPS	Passed
	BFSK	Passed
	Modem II	Passed
Radionics D8112	Modem II	Passed
Radionics D9112	BFSK	Not Verified
	Modem IIE	Not Verified
Radionics D9412	BFSK	Passed
	Modem IIIA <sup>2</sup>	Passed
Scantronics Avenger IX AV-9000	10 BPS	Passed
	20 BPS	Passed
	Any DTMF Format	Passed
Silent Knight 5104	20 BPS	Passed
	BFSK	Passed
	SIA	Passed
	SK FSK1	Passed
Silent Knight 1410		Not Verified
Silent Knight 2820	20 BPS Silent Knight	Not Verified
	BFSK	Passed
	Silent Knight FSK 1	Not Verified
	SIA	Not Verified
Silent Knight 4720	10 BPS SESCOA	Not Verified
	20 BPS Silent Knight	Not Verified
	BFSK	Not Verified
	Silent Knight FSK 1	Not Verified
	Silent Knight FSK 2	Not Verified
	SIA	Passed
Silent Knight 5107	Silent Knight FSK 1	Passed
Silent Knight 5204	10 BPS SESCOA	Not Verified
	10 BPS Silent Knight	Not Verified
	20 BPS Silent Knight	Not Verified
	SIA	Not Verified
	Silent Knight FSK	Not Verified
Silent Knight 5207	20 BPS Silent Knight	Not Verified
	Silent Knight FSK	Not Verified
	BFSK	Not Verified
	SIA	Not Verified
Sur Gard DC1664LC	10 BPS	Passed
	20 BPS	Passed
	40 BPS	Passed
	Any DTMF Format	Passed
	SIA	Passed
Sur Gard P16/P16LC	10 BPS	Passed
	15 BPS	Passed
	20 BPS	Passed
	40 BPS	Passed
	Any DTMF Format	Passed
	SIA	Passed
Sur Gard P1664LC	10 BPS	Passed
	20 BPS	Passed

Panel	Formats	Passed/Failed
	40 BPS	Passed
	Any DTMF Format	Passed
	SIA	Passed
Linear 1704/SSD	Linear FSK	Not Supported
Westec 800	Westec Format 3	Not Supported
Westec 900	Westec Format 1	Not Supported
Westec 2000 Old	Westec Format 2	Not Supported
Westec 2000 C2K	Westec Format 5	Not Supported
Westec 3000	Westec Format 5	Not Supported
Westec 4000	Westec Format 5	Not Supported
Westec 5000	Westec Format 6	Not Supported
ADT A910	Multi-point II	Passed
ADT Focus D50	ADT SIA	Passed
ADT Focus 45	Old Focus FSK	Passed
ADT Focus 45B	Multi-point II	Passed
ADT Focus 48	Old Focus FSK	Passed
ADT Focus 100B	Old Focus FSK	Passed
ADT Focus 100C	Multi-point II	Passed
ADT Focus 100D	ADT SIA	Passed
ADT Focus 200	ADT SIA	Passed
ADT Focus 200B	ADT SIA	Passed
ADT Focus 200P	ADT SIA	Passed
ADT Focus7580	Old Focus FSK	Passed
ADT Safewatch + RF	ADT SIA	Passed
ADT Unimode 5	ADT SIA	Passed

## **WARNING Please Read Carefully**

### **Note to Installers**

This warning contains vital information. As the only individual in contact with system users, it is your responsibility to bring each item in this warning to the attention of the users of this system.

### **System Failures**

This system has been carefully designed to be as effective as possible. There are circumstances, however, involving fire, burglary, or other types of emergencies where it may not provide protection. Any alarm system of any type may be compromised deliberately or may fail to operate as expected for a variety of reasons. Some but not all of these reasons may be:

#### **■ Inadequate Installation**

A security system must be installed properly in order to provide adequate protection. Every installation should be evaluated by a security professional to ensure that all access points and areas are covered. Locks and latches on windows and doors must be secure and operate as intended. Windows, doors, walls, ceilings and other building materials must be of sufficient strength and construction to provide the level of protection expected. A reevaluation must be done during and after any construction activity. An evaluation by the fire and/or police department is highly recommended if this service is available.

#### **■ Criminal Knowledge**

This system contains security features which were known to be effective at the time of manufacture. It is possible for persons with criminal intent to develop techniques which reduce the effectiveness of these features. It is important that a security system be reviewed periodically to ensure that its features remain effective and that it be updated or replaced if it is found that it does not provide the protection expected.

#### **■ Access by Intruders**

Intruders may enter through an unprotected access point, circumvent a sensing device, evade detection by moving through an area of insufficient coverage, disconnect a warning device, or interfere with or prevent the proper operation of the system.

#### **■ Power Failure**

Control units, intrusion detectors, smoke detectors and many other security devices require an adequate power supply for proper operation. If a device operates from batteries, it is possible for the batteries to fail. Even if the batteries have not failed, they must be charged, in good condition and installed correctly. If a device operates only by AC power, any interruption, however brief, will render that device inoperative while it does not have power. Power interruptions of any length are often accompanied by voltage fluctuations which may damage electronic equipment such as a security system. After a power interruption has occurred, immediately conduct a complete system test to ensure that the system operates as intended.

#### **■ Failure of Replaceable Batteries**

This system's wireless transmitters have been designed to provide several years of battery life under normal conditions. The expected battery life is a function of the device environment, usage and type. Ambient conditions such as high humidity, high or low temperatures, or large temperature fluctuations may reduce the expected battery life. While each transmitting device has a low battery monitor which identifies when the batteries need to be replaced, this monitor may fail to operate as expected. Regular testing and maintenance will keep the system in good operating condition.

#### **■ Compromise of Radio Frequency (Wireless) Devices**

Signals may not reach the receiver under all circumstances which could include metal objects placed on or near the radio path or deliberate jamming or other inadvertent radio signal interference.

#### **■ System Users**

A user may not be able to operate a panic or emergency switch possibly due to permanent or temporary physical disability, inability to reach the device in time, or unfamiliarity with the correct operation. It is important that all system users be trained in the correct operation of the alarm system and that they know how to respond when the system indicates an alarm.

#### **■ Smoke Detectors**

Smoke detectors that are a part of this system may not properly alert occupants of a fire for a number of reasons, some of which follow. The smoke detectors may have been improperly installed or positioned. Smoke may not be able to reach the smoke detectors, such as when the fire is in a chimney, walls or roofs, or on the other side of closed doors. Smoke detectors may not detect smoke from fires on another level of the residence or building.

Every fire is different in the amount of smoke produced and the rate of burning. Smoke detectors cannot sense all types of fires equally well. Smoke detectors may not provide timely warning of fires caused by carelessness or safety hazards such as smoking in bed, violent explosions, escaping gas, improper storage of flammable materials, overloaded electrical circuits, children playing with matches or arson.

Even if the smoke detector operates as intended, there may be circumstances when there is insufficient warning to allow all occupants to escape in time to avoid injury or death.

#### **■ Motion Detectors**

Motion detectors can only detect motion within the designated areas as shown in their respective installation instructions. They cannot discriminate between intruders and intended occupants. Motion detectors do not provide volumetric area protection. They have multiple beams of detection and motion can only be detected in unobstructed areas covered by these beams. They cannot detect motion which occurs behind walls, ceilings, floor, closed doors, glass partitions, glass doors or windows. Any type of tampering whether intentional or unintentional such as masking, painting, or spraying of any material on the lenses, mirrors, windows or any other part of the detection system will impair its proper operation.

Passive infrared motion detectors operate by sensing changes in temperature. However their effectiveness can be reduced when the ambient temperature rises near or above body temperature or if there are intentional or unintentional sources of heat in or near the detection area. Some of these heat sources could be heaters, radiators, stoves, barbecues, fireplaces, sunlight, steam vents, lighting and so on.

#### **■ Warning Devices**

Warning devices such as sirens, bells, horns, or strobes may not warn people or waken someone sleeping if there is an intervening wall or door. If warning devices are located on a different level of the residence or premise, then it is less likely that the occupants will be alerted or awakened. Audible warning devices may be interfered with by other noise sources such as stereos, radios, televisions, air conditioners or other appliances, or passing traffic. Audible warning devices, however loud, may not be heard by a hearing-impaired person.

#### **■ Telephone Lines**

If telephone lines are used to transmit alarms, they may be out of service or busy for certain periods of time. Also an intruder may cut the telephone line or defeat its operation by more sophisticated means which may be difficult to detect.

#### **■ Insufficient Time**

There may be circumstances when the system will operate as intended, yet the occupants will not be protected from the emergency due to their inability to respond to the warnings in a timely manner. If the system is monitored, the response may not occur in time to protect the occupants or their belongings.

#### **■ Component Failure**

Although every effort has been made to make this system as reliable as possible, the system may fail to function as intended due to the failure of a component.

#### **■ Inadequate Testing**

Most problems that would prevent an alarm system from operating as intended can be found by regular testing and maintenance. The complete system should be tested weekly and immediately after a break-in, an attempted break-in, a fire, a storm, an earthquake, an accident, or any kind of construction activity inside or outside the premises. The testing should include all sensing devices, keypads, consoles, alarm indicating devices and any other operational devices that are part of the system.

#### **■ Security and Insurance**

Regardless of its capabilities, an alarm system is not a substitute for property or life insurance. An alarm system also is not a substitute for property owners, renters, or other occupants to act prudently to prevent or minimize the harmful effects of an emergency situation.

## **Limited Warranty**

Digital Security Controls Ltd. (DSC) warrants the original purchaser that for a period of twelve months from the date of purchase, the product shall be free of defects in materials and workmanship under normal use. During the warranty period, Digital Security Controls Ltd. shall, at its option, repair or replace any defective product upon return of the product to its factory, at no charge for labour and materials. Any replacement and/or repaired parts are warranted for the remainder of the original warranty or ninety (90) days, whichever is longer. The original purchaser must promptly notify Digital Security Controls Ltd. in writing that there is defect in material or workmanship, such written notice to be received in all events prior to expiration of the warranty period. There is absolutely no warranty on software and all software products are sold as a user license under the terms of the software license agreement included with the product. The Customer assumes all responsibility for the proper selection, installation, operation and maintenance of any products purchased from DSC. Custom products are only warranted to the extent that they do not function upon delivery. In such cases, DSC can replace or credit at its option.

### **International Warranty**

The warranty for international customers is the same as for any customer within Canada and the United States, with the exception that Digital Security Controls Ltd. shall not be responsible for any customs fees, taxes, or VAT that may be due.

### **Warranty Procedure**

To obtain service under this warranty, please return the item(s) in question to the point of purchase. All authorized distributors and dealers have a warranty program. Anyone returning goods to Digital Security Controls Ltd. must first obtain an authorization number. Digital Security Controls Ltd. will not accept any shipment whatsoever for which prior authorization has not been obtained.

### **Conditions to Void Warranty**

This warranty applies only to defects in parts and workmanship relating to normal use. It does not cover:

- damage incurred in shipping or handling;
- damage caused by disaster such as fire, flood, wind, earthquake or lightning;
- damage due to causes beyond the control of Digital Security Controls Ltd. such as excessive voltage, mechanical shock or water damage;
- damage caused by unauthorized attachment, alterations, modifications or foreign objects;
- damage caused by peripherals (unless such peripherals were supplied by Digital Security Controls Ltd.);
- defects caused by failure to provide a suitable installation environment for the products;
- damage caused by use of the products for purposes other than those for which it was designed;
- damage from improper maintenance;
- damage arising out of any other abuse, mishandling or improper application of the products.

### **Items Not Covered by Warranty**

In addition to the items which void the Warranty, the following items shall not be covered by Warranty: (i) freight cost to the repair centre; (ii) products which are not identified with DSC's product label and lot number or serial number; (iii) products disassembled or repaired in such a manner as to adversely affect performance or prevent adequate inspection or testing to verify any warranty claim. Access cards or tags returned for replacement under warranty will be credited or replaced at DSC's option. Products not covered by this warranty, or otherwise out of warranty due to age, misuse, or damage shall be evaluated, and a repair estimate shall be provided. No repair work will be performed until a valid purchase order is received from the Customer and a Return Merchandise Authorisation number (RMA) is issued by DSC's Customer Service.

Digital Security Controls Ltd.'s liability for failure to repair the product under this warranty after a reasonable number of attempts will be limited to a replacement of the product, as the exclusive remedy for breach of warranty. Under no circumstances shall Digital Security Controls Ltd. be liable for any special, incidental, or consequential damages based upon breach of warranty, breach of contract, negligence, strict liability, or any other legal theory. Such damages include, but are not limited to, loss of profits, loss of the product or any associated equipment, cost of capital, cost of substitute or replacement equipment, facilities or services, down time, purchaser's time, the claims of third parties, including customers, and injury to property. The laws of some jurisdictions limit or do not allow the disclaimer of consequential damages. If the laws of such a jurisdiction apply to any claim by or against DSC, the limitations and disclaimers contained here shall be to the greatest extent permitted by law. Some states do not allow the exclusion or limitation of incidental or consequential damages, so that the above may not apply to you.

### **Disclaimer of Warranties**

*This warranty contains the entire warranty and shall be in lieu of any and all other warranties, whether expressed or implied (including all implied warranties of merchantability or fitness for a particular purpose) And of all other obligations or liabilities on the part of Digital Security Controls Ltd. Digital Security Controls Ltd. neither assumes responsibility for, nor authorizes any other person purporting to act on its behalf to modify or to change this warranty, nor to assume for it any other warranty or liability concerning this product.*

*This disclaimer of warranties and limited warranty are governed by the laws of the province of Ontario, Canada.*

**WARNING: Digital Security Controls Ltd. recommends that the entire system be completely tested on a regular basis. However, despite frequent testing, and due to, but not limited to, criminal tampering or electrical disruption, it is possible for this product to fail to perform as expected.**

### **Installer's Lockout**

Any products returned to DSC which have the Installer's Lockout option enabled and exhibit no other problems will be subject to a service charge.

### **Out of Warranty Repairs**

Digital Security Controls Ltd. will at its option repair or replace out-of-warranty products which are returned to its factory according to the following conditions. Anyone returning goods to Digital Security Controls Ltd. must first obtain an authorization number. Digital Security Controls Ltd. will not accept any shipment whatsoever for which prior authorization has not been obtained.

Products which Digital Security Controls Ltd. determines to be repairable will be repaired and returned. A set fee which Digital Security Controls Ltd. has predetermined and which may be revised from time to time, will be charged for each unit repaired.

Products which Digital Security Controls Ltd. determines not to be repairable will be replaced by the nearest equivalent product available at that time. The current market price of the replacement product will be charged for each replacement unit.



©2003 Digital Security Controls Ltd.  
Toronto, Canada • [www.dsc.com](http://www.dsc.com)  
Sales: 1-888-888-7838  
Tech. Support (Canada & USA): 1-800-503-5869

Direct all comments concerning  
this publication to [pubs@dsc ltd.com](mailto:pubs@dsc ltd.com)  
Printed in Canada



29034637R001