



QUEST 2000

Advanced Image Processing Motion Detector

INSTALLATION INSTRUCTIONS

GENERAL INFORMATION

Ademco has taken the next step on motion detector technology with the QUEST 2000, Ademco's Image Processing detector.

The QUEST 2000 is a "thinking" detector which uses a combination of two diverse methods of detection to improve false alarm immunity. The passive infrared detector provides 22 zones of wide angle coverage with a range of 40 feet (12.2m). In addition, there is a "look-down" zone that provides protection in the area close to the mounting wall. A microwave detector provides alarm verification.

The PIR optical system divides the area into a series of protected zones. A dual element PIR sensor measures the level of infrared energy in each zone. The microwave system provides a volumetric coverage pattern. When an intruder enters the combined PIR/microwave protective pattern, PIR and microwave signals will be generated at the same time and the detector's relay will report an alarm. The QUEST 2000 includes a microprocessor with analog-to-digital conversion which provides:

- Dual technology signal processing for immunity to environmental disturbances and reduced false alarms.
- Ademco image processing of 256 different environmental condition levels.
- Adaptive microwave signal processing for false alarm immunity.
- 40 ft (12m) x 50 ft (15m) range with "look-down" zone.
- Adjustable microwave range with potentiometer.
- Rejection (with digital notch filter) of fluorescent light disturbances.
- Trouble output. Unit performs self-test and reports a failure. Unit continues to operate as PIR only.
- Alarm LED local and remote disable.
- Digital pulse count and pulse recognition provides false alarm immunity in harsh environments.
- True digital temperature compensation.
- DIP switch selectable functions: walk test, Pulse Count 3 (PIR), Alarm LED disable.
- Ademco ACCU-TRAK walk test feature for faster installation.

These additional conventional features are included:

- Dual element pyroelectric PIR sensor and Fresnel optics.
- Superior lens design. Does not require any optics adjustment.
- Low current drain, which allows for extended power source standby battery life.
- 12VDC operation.
- Wall and corner mounting bracket provided.
- Optional swivel bracket is available.

COVERAGE AND LOCATION CONSIDERATIONS

Combined protective patterns are shown in Diagram 1, for a nominal mounting height of 7.5ft (2.3m).

The microwave detection pattern shown in Diagram 1 represents coverage in open space. In practical applications, when the detector is bounded by ceiling, floor, and walls, reflections occur and the device provides volumetric coverage.

Selecting a Mounting Location

The detector responds to changes in energy which occur when an intruder moves into the combined protection pattern. Best coverage will be obtained if the mounting site is selected so that the likely direction of intruder motion is generally *across* the pattern and angles slightly *toward* the detector (see Diagram 1).

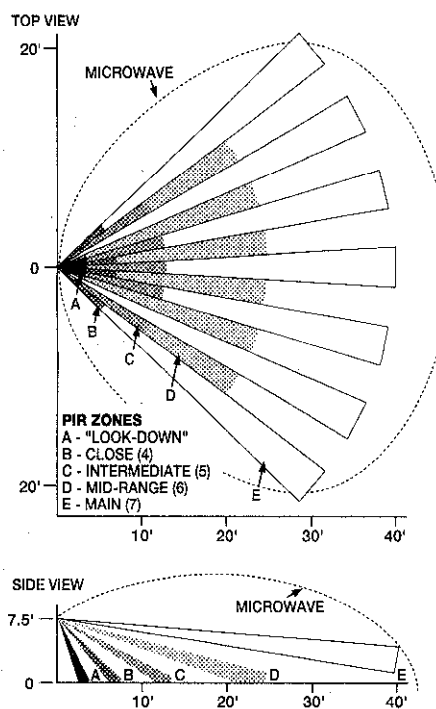

Diagram 1: PROTECTION PATTERN

Installation Hints

The detector is remarkably resistant to false alarm hazards, but the following recommendations should be observed:

- Select a mounting height approximately 7.5ft (2.3m) above the floor.
- Do not mount on an unstable surface. Locate the unit on a sturdy inside wall whenever possible. Avoid sources of vibration such as loose fitting doors and walls that shake when heavy traffic exists.
- Do not install on or close to metal structures such as metal door frames, shelves, etc.
- Do not include space heaters in the protective pattern whenever possible, to avoid rapid temperature changes and vibration from fans.

- Avoid aiming directly at a fluorescent light. Keep at least 20ft (6.1m) away from them if possible. They present variable reflections to the microwave sensor.
- Microwave transmission *penetrates* most building material (except metal, which *reflects* transmission). Moving objects outside of the protected area may, therefore, be detected unless the microwave sensitivity control is kept at as low a setting as possible, to minimize penetration.
- Make sure the detection area does not have obstructions (curtains, screens, large pieces of furniture, plants, etc.) which may block the PIR portion of the coverage pattern.

Important: Avoid running alarm wiring close to heavy duty electrical power cables.

INSTALLATION

Mounting

1. **Remove front cover** by twisting a screwdriver blade in the groove between cover and base at the location shown in Diagram 2 and then lifting the cover off.
2. **Mount wall plate** to a firm vertical surface (flat on wall or in corner). Position the plate so that field wiring is centered in the hole at the top of the plate [wall wiring hole no larger than 5/16" (8mm) diameter]. See Diagram 3.
3. **Feed wiring** through the wiring hole in the bracket, and via the wiring trough at the rear of the base through the wiring hole in the base. *Do not connect to terminal block yet.*
4. **Attach unit to wall plate** by engaging all four hooks on the plate into slots on the rear of the base and by sliding the unit downward. See Diagram 3.

Note: The unit is locked to the wall plate by a plastic spring tab in the plate that engages an opening in the housing base (see Diagram 3). The unit can only be removed from the plate by removing the cover, depressing the tab (via a hole in the base) with a small blade screwdriver, and then sliding the unit upward (see Diagram 4).

Use of the wall plate provided is recommended. If you choose not to use the wall plate, knockout holes for direct wall or corner mounting are provided in the unit's base (to gain access to them, the circuit board must be carefully removed from the base by bending back the circuit board holding tab at the lower edge of the board). Do not use the unit's "wall plate keyholes" for direct mounting; use the mounting holes above the "keyholes" (or to the left and right of the "keyholes" for corner mount).

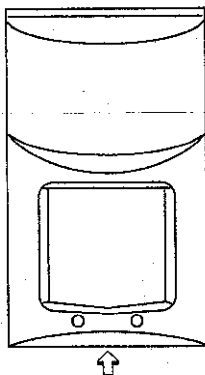

- 1) TWIST SCREWDRIVER BLADE IN GROOVE.
- 2) LIFT COVER OFF.

Diagram 2: COVER REMOVAL

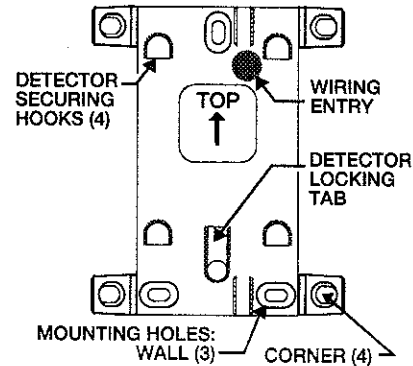

Diagram 3: WALL PLATE

Wiring Connections (see Diagram 4)

Bring all wires through the unit's wiring entry near the terminal block and make connections as indicated in Diagram 4 and in the table below.

TERM	FUNCTION
1	+12V Input Supply. Power must be provided from a 12VDC filtered source with 25mA capability and at least 4 hours of standby battery capacity.
2	(-) Input Supply (ground).
3 & 4	Relay Contacts. N.C. (open on alarm). Connect to closed protective circuit.
5	Alarm LED Remote Disable. Apply +12V to disable alarm indication (same as setting DIP switch #3 UP).
6	Trouble Output. Upon supervision failure, this open collector output will go low (requires 1000-ohm pull-up resistor). Use shielded wire for UL installations. Locally, both LEDs will flash to annunciate trouble. The detector continues to operate as PIR only.

Adjustments and Selections

MICROWAVE SENSITIVITY CONTROL:

Turn the Potentiometer clockwise to increase sensitivity.

DIP SWITCH SETTINGS:

- #1: UP for Walk Test selection (relay will remain open while Test is selected).
- #2: UP for setting Pulse Count to 3.
- #3: UP for alarm LED disable (disables alarm indication only).
- #4: UNUSED

TESTING

Important: Wait at least two minutes after applying power before attempting to walk-test unit.

Conduct the walk testing of the detector with the protected area cleared of all people. In some business establishments, it may be more convenient to do this after the business is closed. The protective system's control should be disarmed during the procedure to prevent reporting unwanted alarms.

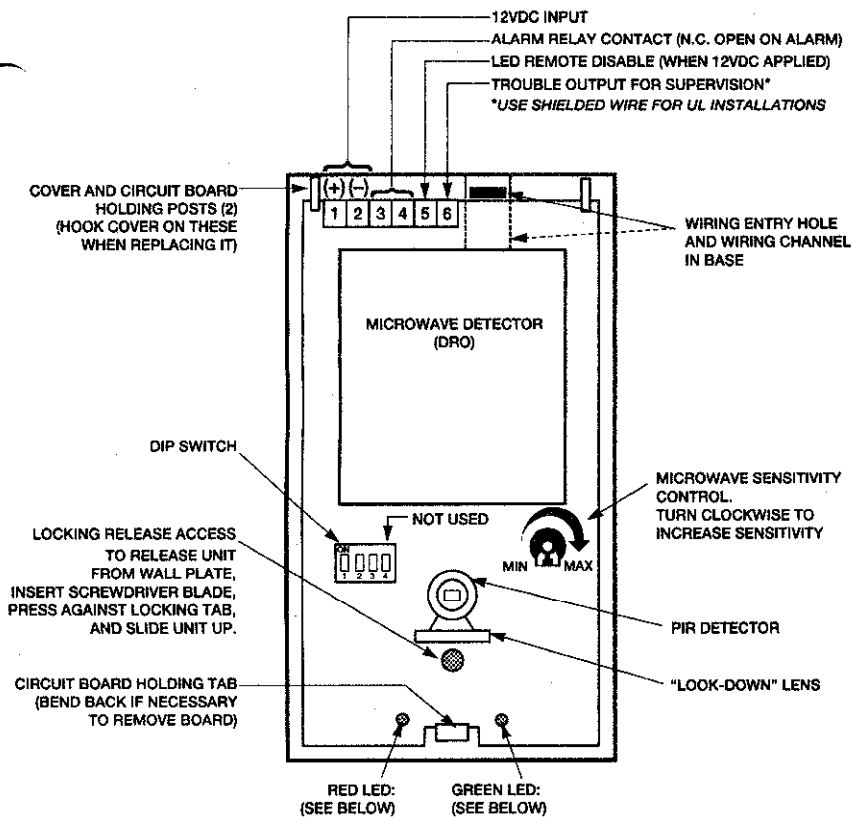

LED INDICATIONS:

POWER UP: Red and Green LEDs on for approx. 90 secs.

SUPERVISION FAILURE: Red and Green LEDs flashing.

ALARM: Red LED on.

WALK TEST (when selected via DIP switch #1):
 Green LED flashes for microwave.
 Red LED flashes for PIR.

Note: When Walk Test is selected, alarm relay is constantly held open to prevent leaving the detector in the walk test mode..

Diagram 4: INTERIOR OF DETECTOR

ACCU-TRAK Walk-Test

Ademco's unique ACCU-TRAK walk test feature is easy to use. Simply set DIP Switch #1 UP.

Both microwave and PIR information is viewable simultaneously on the two LEDs, providing crisp, immediate feedback (see below). As you enter the protected area, ACCU-TRAK responds and lights the LEDs; when you stop moving or leave the protected area, the LEDs extinguish immediately. In addition, the flash rate of the microwave LED (green) is directly proportional to speed at which movement occurs; the PIR LED (red) blinks as you enter or leave each zone. This will give precise feedback during walk testing, so that you can easily determine the exact pattern of coverage for the installation.

Green LED flashes for microwave.

Red LED flashes for PIR zone crossings

Note: Alarm relay remains continuously open when walk test is selected to prevent leaving the detector in the walk test mode.

LED Disable

In some installations, it may be desirable to disable the Alarm LED after the initial tests at installation, in order to

SPECIFICATIONS

Detection Method: Dual Technology Microwave/PIR.

Coverage: 40ft (12m) x 50ft (15m).

Detection Pattern:

PIR: 22 Zones (7 Main, 6 Midrange, 5 Intermediate, 4 Close) plus one "Look-down" zone.

Microwave: Volumetric coverage.

Mounting Height: 7.5ft nominal (2.3m), wall/corner mounting.

Indicators: Red and Green LEDs (see LED INDICATIONS in Diagram 4).

Alarm Relay Contacts: SPST (Form A) reed with 15-ohm protective resistor, 50 mA max at 24VDC (non-inductive).

Input Voltage: 12VDC nominal. (reversing voltage polarity makes detector inoperative.)

Current: 25mA (40mA during power up).

Standby Capability: Power source should be capable of at least 4 hours of battery standby.

Operating Temperature: +14°F to +122°F (-10°C to +50°C).

Operating Humidity: Up to 95% RH (max.) non-condensing.

Dimensions: 3-13/16" W
 4-7/8" H
 2" D (w/wall plate)
 (97mm x 124mm x 51mm).

prevent potential intruders from determining the exact limits of the protected area. This is accomplished remotely whenever 12VDC(+) is applied to terminal 5, or locally when DIP switch position 3 is UP.

MAINTAINING PROPER OPERATION

In order to maintain the detector in proper working condition, it is important that the following be observed by the user:

1. **Power should be provided at all times.** Loss of power to the unit will result in the alarm contacts reverting to an alarm state. The unit's DC source should have standby power available for at least 4 hours of operation during emergencies.
2. **Units should never be re-aimed or relocated** without the advice or assistance of the alarm service company.
3. **The physical surroundings of the protected area should not be changed.** If furniture or stock is moved, or air conditioning or additional heating is installed, the system may have to be readjusted by the alarm service company.
4. **Walk-tests should be conducted frequently (at least weekly)** to confirm proper coverage by each detector.

TO THE INSTALLER

Regular maintenance and inspection (at least annually) by the installer and frequent testing by the user are vital to continuous satisfactory operation of any alarm system. The installer should assume the responsibility of developing and offering a regular maintenance program to the user, as well as acquainting the user with the proper operation and limitations of the alarm system and its component parts. Recommendations must be included for a specific program of frequent testing (at least weekly) to insure the system's operation at all times.

WARNING! **THE LIMITATIONS OF YOUR MICROWAVE/PASSIVE INFRARED MOTION DETECTOR**

While this Intrusion Detector is a highly reliable intrusion detection device, it does not offer guaranteed protection against burglary. Any Intrusion Detection device is subject to compromise or failure to warn for a variety of reasons. For example:

- These Motion Detectors can only detect intrusion within the designed ranges as diagrammed in this installation manual.
- The passive infrared sensor in this Motion Detector does not provide volumetric area protection. It does create multiple beams of protection, and intrusion can only be detected in unobstructed areas covered by those beams.
- Passive Infrared Detectors can not detect motion or intrusion that takes place behind walls, ceilings, floors, closed doors, glass partitions, glass doors, or windows.
- Metal objects (or other reflectors, such as foil faced insulation or water in bottles) can alter the microwave sensor's protection pattern.
- Mechanical tampering, masking, painting or spraying of any material on the lenses, windows or any part of the optical system can reduce the detection ability of the Passive Infrared Motion Detector.
- Passive Infrared Detectors sense changes in temperature; however, as the ambient temperature of the protected area approaches the temperature range of 90° to 105°F (32° to 40°C), the detection performance can decrease.
- This Detector will not operate without appropriate DC power connected to it, or if the DC power is improperly connected (i.e., reversed polarity connections).
- These Detectors, like other electrical devices, are subject to component failure. Even though this equipment is designed to last as long as 10 years, the electronic components in it could fail at any time.

We have cited some of the most common reasons that this Motion Detector can fail to catch intrusion. However, this does not imply that these are the only reasons, and therefore it is recommended that weekly testing of this type of unit, in conjunction with weekly testing of the entire alarm system, be performed to ensure that the detectors are working properly.

Installing an alarm system may make the owner eligible for a lower insurance rate, but an alarm system is not a substitute for insurance. Homeowners, property owners and renters should continue to act prudently in protecting themselves and continue to insure their lives and property.

We continue to develop new and improved protection devices. Users of alarm systems owe it to themselves and their loved ones to learn about these developments.

FEDERAL COMMUNICATIONS COMMISSION (FCC) STATEMENT

The user shall not make any changes or modifications to the equipment unless authorized by the Installation Instructions or User's Manual. Unauthorized changes or modifications could void the user's authority to operate the equipment.

ADEMCO SIX YEAR LIMITED WARRANTY

Alarm Device Manufacturing Company, a Division of Pittway Corporation, and its divisions, subsidiaries and affiliates ("Seller"), 165 Eileen Way, Syosset, New York 11791, warrants this PIR/Microwave Detector to be in conformance with its own plans and specifications and to be free from defects in materials and workmanship under normal use and service for 72 months from the date stamp control on the product Seller's obligation shall be limited to replacing, at its option, free of charge for materials or labor, a detector which is proved not in compliance with Seller's specifications or proves defective in materials or workmanship under normal use and service. Seller shall have no obligation under this Limited Warranty or otherwise if the detector is altered or improperly repaired or serviced by anyone other than Ademco factory service. In case of defect, return the detector to Ademco Distribution, Inc. or an authorized Ademco distributor for an immediate replacement.

THERE ARE NO WARRANTIES, EXPRESS OR IMPLIED, OF MERCHANTABILITY, OR FITNESS FOR A PARTICULAR PURPOSE OR OTHERWISE, WHICH EXTEND BEYOND THE DESCRIPTION ON THE FACE HEREOF. IN NO CASE SHALL SELLER BE LIABLE TO ANYONE FOR ANY CONSEQUENTIAL OR INCIDENTAL DAMAGES FOR BREACH OF THIS OR ANY OTHER WARRANTY, EXPRESS OR IMPLIED, OR UPON ANY OTHER BASIS OF LIABILITY WHATSOEVER, EVEN IF THE LOSS OR DAMAGE IS CAUSED BY THE SELLER'S OWN NEGLIGENCE OR FAULT.

Seller does not represent that its detector may not be compromised or circumvented; that the detector will prevent any personal injury or property loss by burglary, robbery, fire or otherwise; or that the detector will in all cases provide adequate warning or protection. Buyer understands that a properly installed and maintained alarm may only reduce the risk of a burglary, robbery, fire or other events occurring without providing an alarm, but it is not insurance or a guarantee that such will not occur or that there will be no personal injury or property loss as a result. CONSEQUENTLY, SELLER SHALL HAVE NO LIABILITY FOR ANY PERSONAL INJURY, PROPERTY DAMAGE OR OTHER LOSS BASED ON A CLAIM THE DETECTOR FAILED TO GIVE WARNING. HOWEVER, IF SELLER IS HELD LIABLE, WHETHER DIRECTLY OR INDIRECTLY, FOR ANY LOSS OR DAMAGE ARISING UNDER THIS LIMITED WARRANTY OR OTHERWISE, REGARDLESS OF CAUSE OR ORIGIN, SELLER'S MAXIMUM LIABILITY SHALL NOT IN ANY CASE EXCEED THE PURCHASE PRICE OF THE DETECTOR, WHICH SHALL BE THE COMPLETE AND EXCLUSIVE REMEDY AGAINST SELLER. This warranty replaces any previous warranties and is the only warranty made by Seller on this detector. No increase or alteration, written or verbal, of the obligations of this Limited Warranty is authorized.

ADEMCO

A Division of Pittway Corporation

165 Eileen Way, Syosset, New York 11791

Copyright © 1995 PITTWAY CORPORATION