



# INSTALLATION INSTRUCTIONS

## PS24 POWER SUPPLY MODULE

### GENERAL INFORMATION

The PS24 power supply module is an accessory for Ademco control panels intended for use in commercial fire installations. The PS24 has two triggerable 24VFW (full wave rectified, unfiltered), 1.7 amp outputs that can either provide 24VFW auxiliary power, or can convert up to two control panel 12VDC EOLR supervised bell circuit outputs to 24VFW EOLR supervised bell outputs.

Each of the PS24 outputs, labeled OUTPUT A and OUTPUT B, has a corresponding controlling input, labeled INPUT A and INPUT B, respectively. Negative voltages applied to INPUT A and INPUT B are passed through to the associated output, allowing the control panel to supervise bell circuit wiring connected to that output (as required for installations which use the output for 24VFW, EOLR-supervised bell circuit operation). Applying positive voltages of 9.5–14VDC to INPUT A and INPUT B produces 24VFW at the respective output terminals.

For installations which require 24VFW auxiliary power, you must wire INPUT A and/or INPUT B to the control panel's 12VDC auxiliary power terminals so that the associated PS24 output remains activated continuously. For installations which require 24VFW EOLR supervised bells, you must wire INPUT A and /or INPUT B to the control panel's 12VDC EOLR supervised bell terminals.

Primary power for the PS24 power supply module is supplied by a 1451-24 transformer, which consists of an AC power transformer and a manually resettable circuit breaker mounted inside a protective enclosure. The 1451-24 transformer has two secondary windings – a 30VAC/188VA winding which is used to power the PS24 module, and a 18VAC/72VA winding which is used to power the control panel. The PS24 module monitors its connection to the 1451-24 and can report a low AC condition to the control panel via one of the control panel's EOLR supervised zones.

#### Notes:

1. The 1451-24 transformer is not supplied with the PS24 unless part of a kit (see Note 2).
2. Complete control panel kits are available, consisting of the control panel, PS24 module, and 1451-24 transformer. For example, a 5140XM control panel kit is available under part No. 5140XM-24ADA, and consists of the 5140XM control panel, PS24 module, 1451-24 transformer, and a few other peripheral devices.

Secondary power for the PS24 power supply module is supplied by a pair of 12VDC lead-acid (gel cell) batteries rated at 7AH minimum, 17.2AH maximum. Both batteries connect directly to the PS24 module which internally configures them to provide 24V back-up power for its outputs, and 12V back-up power for the control panel. The PS24 module charges and tests these batteries, and can report a low or disconnected battery condition to the control panel via one of the control panel's EOLR supervised zones.

### MOUNTING

The PS24 module is designed to mount inside the control panel enclosure.

Referring to Figure 1, attach the PS24 PCB to the metal bracket (supplied) using the four #6 sheet metal screws (supplied). Then, clip the PS24 bracket onto the left sidewall of the control panel enclosure as shown in Figure 2. This method of mounting leaves room in the control panel's enclosure for the panel/module back-up batteries.

**Note:** The control panel enclosure should be mounted to the wall before attempting to install the PS24 module because the PS24 will block access to the control's left mounting hole.

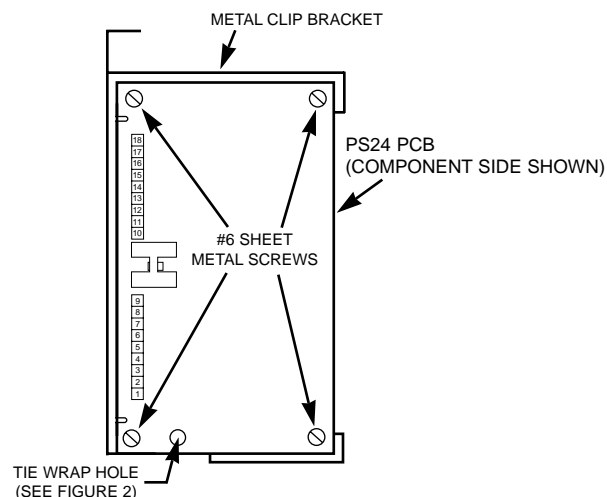

Figure 1.

#### Mounting the PS24 PCB to the Metal Clip Bracket

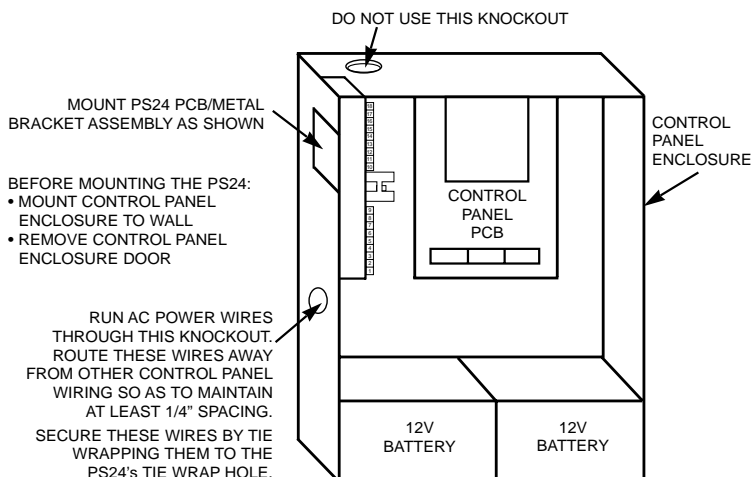

Figure 2.

#### Mounting the PS24 Inside the Control Panel Enclosure

### BATTERY CAPACITY CALCULATIONS

The PS24 module requires connection of two 12VDC lead acid (gel cell) batteries rated at 7AH minimum/17.2AH maximum. The PS24 configures these batteries to provide 24V back-up power for its 24V outputs and 12V back-up power for the control panel. See the CONNECTIONS AND POWER UP PROCEDURES section for battery connection details.

#### UL NOTE:

UL requires that the battery's capacity be sized for 24 hours of standby time, followed by 5 minutes of alarm time for commercial fire installations or 15 minutes of alarm time for commercial fire/burglary installations. Appropriate battery capacity can be calculated using the worksheets on the next page.

1. Fill in the total control panel standby and alarm currents in the worksheet below. These totals must include the control panel's PCB currents as well as the currents drawn from the control panel's auxiliary power and bell power outputs. Refer to the control panel's installation instructions to determine these currents.

## BATTERY CAPACITY CALCULATIONS (Cont'd)

2. Fill in the **Total PS24 MODULE Load Worksheet**, below, to determine the PS24's total standby and alarm current loading. Then use the **BATTERY CAPACITY CALCULATION WORKSHEET** to determine the capacity required for each of the PS24's batteries.

Select 12-volt batteries from the **BATTERY SELECTION TABLE** having capacities which are greater than, or equal to, the calculated capacities.

## BATTERY CALCULATION WORKSHEETS

Total Control Panel Load	Standby	Alarm
Total control panel load at 12V (Note 1) (from control panel worksheets)		
Equivalent control panel load at 24V (multiply above values by 0.62)		

Total PS24 Module Load Worksheet	Standby	Alarm
Total OUTPUT A load (Notes 2, 3) (total for all devices on OUTPUT A)	(570 mA max)	(1.7A max)
Total OUTPUT B load (Notes 2, 3) (total for all devices on OUTPUT B)	(570 mA max)	(1.7A max)
CONTROL BATTERY POWER load (equivalent control panel load at 24V as calculated above)		
PS24 PCB current (these values are fixed)	40 mA	40 mA
Total PS24 module load (Note 3) (add currents in columns above)	(610 mA max)	(4.18A max)

### NOTE 1:

Input A and Input B draw 50mA from the control panel when 9.5V–14V is applied to actuate the corresponding output. Be sure to include this in the control panel's total load.

### NOTE 2:

When configured for auxiliary power operation, enter the continuous load in the standby column and enter the continuous load plus any additional intermittent alarm load in the alarm column. When configured for bell circuit operation, enter "0" in the standby column and enter total load in the alarm column.

### NOTE 3:

The largest battery capacity supported by the PS24 is 17.2AH. Total PS24 standby current must be limited to 610mA maximum for this battery.

## BATTERY CAPACITY CALCULATION WORKSHEET

Capacity	Formula	Calculated Value
Standby Capacity	Total standby load x 24 hours x 1.1 contingency factor (use total PS24 standby load)	
Alarm Capacity	Total alarm load x alarm time in hours i.e.: 5 minutes = 0.083 hours 15 minutes = 0.250 hours (use total PS24 alarm load)	
Total Capacity	Add standby and alarm capacities	

## BATTERY SELECTION TABLE

Amp Hours	Yuasa Model Number	Comments
7 AH	NP7-12	2 required
12 AH	NP12-12	2 required
17.2 AH	NPG18-12	2 required

### NOTE:

Use two batteries from the same manufacturer, with the same capacity and with approximately the same age. Replace both batteries at the same time even if only one battery is low.

## CONNECTIONS AND POWER UP PROCEDURES

A 7-wire harness, consisting of six # 22 AWG and one #16 AWG wires, is provided for making connections between the PS24 and the control panel. Use the #22 AWG wires to make connections to the PS24's INPUT A, INPUT B, LOW AC, and LOW BATTERY terminals. Use the #16 AWG wire to make connections to the PS24's Earth Ground terminal.

Wire AC power and earth ground as shown in Figure 3. **DO NOT APPLY AC POWER AT THIS TIME.**

- Wire INPUT A, INPUT B, OUTPUT A and OUTPUT B for the desired auxiliary power or bell circuit operation as shown in Figure 3. Devices powered from OUTPUT A or from OUTPUT B must be rated for 21–30VFW (full wave rectified, unfiltered) operation.

The following UL Listed devices are compatible with outputs configured for auxiliary power operation.

First Inertia Switch Model FIRERAY 1401	Photoelectric beam smoke detector
ESL Model DH-1224	12/24V electromagnetic fire door holder
ESL Model DH-24120	24/120V electromagnetic fire door holder

- Use UL listed, polarized fire indication devices on outputs configured for EOLR supervised bell circuit operation. Refer to the tables below for examples of compatible fire indication devices and for recommended limits on bell circuit wire run length.

- Wire the LOW AC and LOW BATTERY outputs to separate control panel EOLR supervised zones. Program the respective control panel's zones for 24-hour trouble response.
  - Connect the PS24's CONTROL BATTERY POWER output fast-on terminals to the control panel's battery terminals, using the battery cables supplied with the control panel.
  - Apply AC power and verify that the proper battery float charging voltage (27.0–27.6VDC) is present across the BATT 1 (+) and BATT 2 (–) terminals. Then connect two 12V lead-acid batteries as shown in Figure 3, using the battery cables supplied.
- NOTE: The battery cable's female Fast-on terminals should be clipped off when making connections to the 17.2 AH batteries.
- Verify that the LOW AC and LOW BATTERY outputs are in the not-faulted state (i.e.: shorted to ground through 220 ohms).
  - Verify that OUTPUT A and OUTPUT B are in the proper state (i.e.: 24V for auxiliary power operation; not active for bell circuit operation).

## COMPATIBLE UL LISTED INDICATING DEVICES TABLE

NOTE: Use UL listed devices rated for 21–30VFW.

### Horn/Strobes:

System Sensor	MASS2415ADA
System Sensor	MASS2475ADA
System Sensor	MASS24110ADA
System Sensor	MASS241575ADA
Wheelock	MT-24-LS-VFR & MT4-24-LS-VFR
Wheelock	MT-24-LSM-VFR & MT4-24-LSM-VFR
Wheelock	MT-24-MS-VFR & MT4-24-MS-VFR
Wheelock	MT-24-IS-VFR & MT4-24-IS-VFR
Gentex	SHG24-15-1
Gentex	SHG24-1575
Gentex	SHG24-110-1

### Strobes:

System Sensor	SS2415ADA
System Sensor	SS241575ADA
System Sensor	SS2475ADA
System Sensor	SS24110ADA
Wheelock	LS1M-24-VFR
Wheelock	MS1-24-VFR

### Strobes (continued):

Gentex	GXS-4-15-1
Gentex	GXS-4-1575
Gentex	GXS-4-110-1

### BELL CIRCUIT WIRE RUN LENGTH TABLE.

NOTE: Lengths below are measured from PS24 to farthest device on wire run. These lengths correspond to a voltage drop of 2.4V.

Bell Current (mA)	#18 AWG	#16 AWG	#14 AWG	#12 AWG
100	1870 ft	2980 ft	4750 ft	7550 ft
250	750 ft	1190 ft	1900 ft	3020 ft
500	375 ft	590 ft	950 ft	1510 ft
750	250 ft	390 ft	630 ft	1000 ft
1000	180 ft	290 ft	470 ft	750 ft
1250	150 ft	230 ft	380 ft	600 ft
1500	120 ft	190 ft	310 ft	500 ft
1700	110 ft	170 ft	270 ft	440 ft

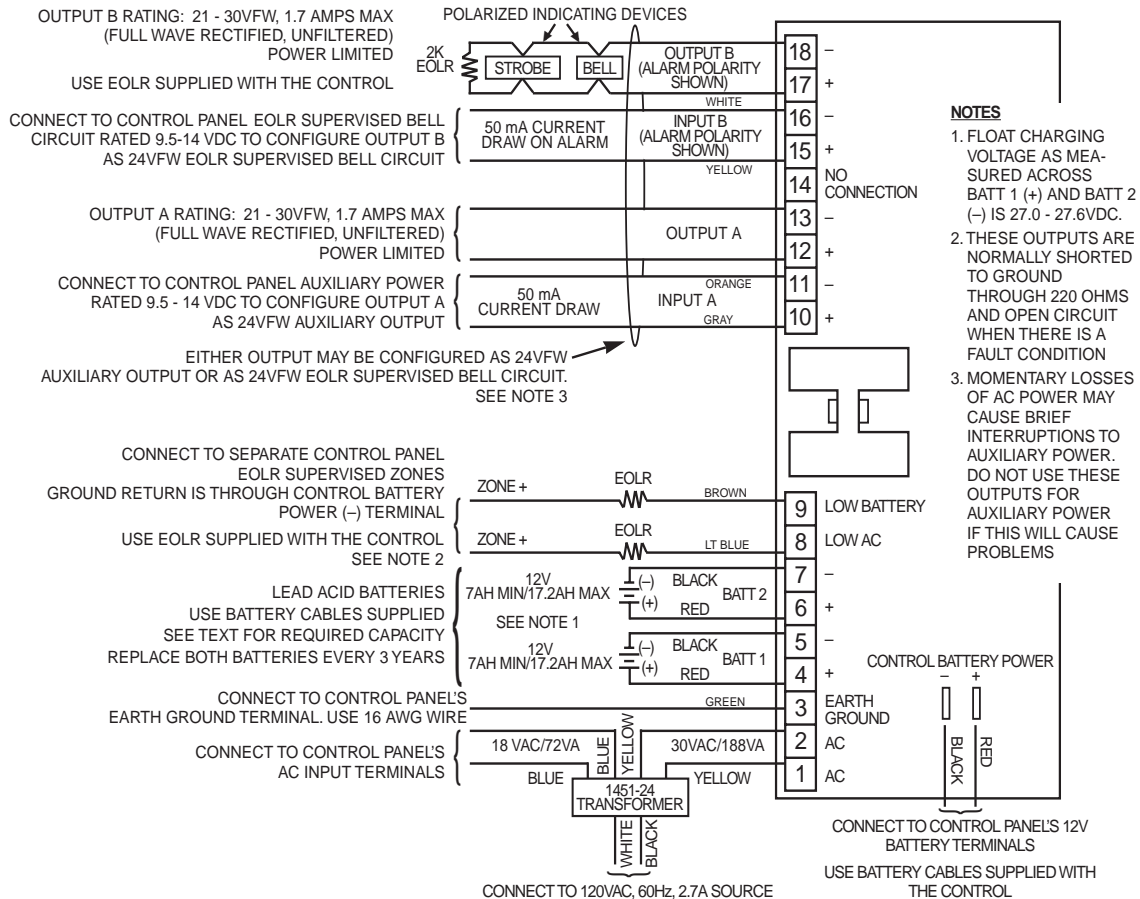

Figure 3. Making Connections to the PS24 Module

## SPECIFICATIONS

### Physical:

4-1/4" W x 9-1/4" H x 2-1/2" D (PCB/bracket size).

### Electrical

**Primary power:** From 1451-24 transformer. Use the 30VAC/188VA secondary winding on this transformer.

**Back-up power:** Use two 12VDC, 7AH min/17.2AH max lead-acid (gel cell) batteries.

Float charging voltage: 27.0–27.6VDC.

Standby time: Up to 24 hours depending on PS24 and control panel loading. See text.

Recharge time: Up to 48 hours.

Fusing: PTC circuit protector.

**INPUT A/INPUT B:** Compatible with control panel auxiliary power and EOLR supervised bell circuit outputs rated 9.5–14VDC.

**Current draw:** 50mA when 9.5–14VDC applied to activated associated output; 0mA otherwise.

**OUTPUT A,** 21–30VFW (24V nominal) full wave rectified,

**OUTPUT B:** unfiltered, 1.7 amps max. For bell circuit operation: Use UL listed, polarized fire indicating devices rated 21–30VFW. The control panel

supervises the 24VFW bell wiring; use the EOLR supplied with the control panel.

**Fusing:** PTC circuit protector. Outputs are power limited.

**CONTROL BATTERY POWER OUTPUT:** For connection to the control panel's 12V battery terminals only. Can supply up to 2.8 amps at 12–12.5V during an AC power outage.

**Fusing:** Internal solid state current limit.

**LOW AC OUTPUT:** Normally shorted to ground through 220 ohms, open circuit when AC power is low.

**LOW BATTERY:** Normally shorted to ground through 220 ohms, open circuit when battery voltage is low (less than approx. 23.0V).

PS24 runs a brief battery test every minute to determine if battery leads are connected and runs an extended battery test every 17 hours to determine if battery capacity is low.

### Agency Listings:

UL864 Listed  
FM, CFM, MEA listings are pending.

## ADEMCO LIMITED WARRANTY

Alarm Device Manufacturing Company, a Division of Pittway Corporation, and its divisions, subsidiaries and affiliates ("Seller"), 165 Eileen Way, Syosset, New York 11791, warrants its products to be in conformance with its own plans and specifications and to be free from defects in materials and workmanship under normal use and service for 18 months from the date stamp control on the product or, for products not having an Ademco date stamp, for 12 months from date of original purchase unless the installation instructions or catalog sets forth a shorter period, in which case the shorter period shall apply. Seller's obligation shall be limited to repairing or replacing, at its option, free of charge for materials or labor, any product which is proved not in compliance with Seller's specifications or proves defective in materials or workmanship under normal use and service. Seller shall have no obligation under this Limited Warranty or otherwise if the product is altered or improperly repaired or serviced by anyone other than Ademco factory service. For warranty service, return product transportation prepaid, to Ademco Factory Service, 165 Eileen Way, Syosset, New York 11791.

THERE ARE NO WARRANTIES, EXPRESS OR IMPLIED, OF MERCHANTABILITY, OR FITNESS FOR A PARTICULAR PURPOSE OR OTHERWISE, WHICH EXTEND BEYOND THE DESCRIPTION ON THE FACE HEREOF. IN NO CASE SHALL SELLER BE LIABLE TO ANYONE FOR ANY CONSEQUENTIAL OR INCIDENTAL DAMAGES FOR BREACH OF THIS OR ANY OTHER WARRANTY, EXPRESS OR IMPLIED, OR UPON ANY OTHER BASIS OF LIABILITY WHATSOEVER, EVEN IF THE LOSS OR DAMAGE IS CAUSED BY THE SELLER'S OWN NEGLIGENCE OR FAULT.

Seller does not represent that the products it sells may not be compromised or circumvented; that the products will prevent any personal injury or property loss by burglary, robbery, fire or otherwise; or that the products will in all cases provide adequate warning or protection. Customer understands that a properly installed and maintained alarm may only reduce the risk of a burglary, robbery, fire or other events occurring without providing an alarm, but it is not insurance or a guarantee that such will not occur or that there will be no personal injury or property loss as a result. CONSEQUENTLY, SELLER SHALL HAVE NO LIABILITY FOR ANY PERSONAL INJURY, PROPERTY DAMAGE OR OTHER LOSS BASED ON A CLAIM THE PRODUCT FAILED TO GIVE WARNING. HOWEVER, IF SELLER IS HELD LIABLE, WHETHER DIRECTLY OR INDIRECTLY, FOR ANY LOSS OR DAMAGE ARISING UNDER THIS LIMITED WARRANTY OR OTHERWISE, REGARDLESS OF CAUSE OR ORIGIN, SELLER'S MAXIMUM LIABILITY SHALL NOT IN ANY CASE EXCEED THE PURCHASE PRICE OF THE PRODUCT, WHICH SHALL BE THE COMPLETE AND EXCLUSIVE REMEDY AGAINST SELLER. This warranty replaces any previous warranties and is the only warranty made by Seller on this product. No increase or alteration, written or verbal, of the obligations of this Limited Warranty is authorized.

SEE THE CONTROL PANEL'S INSTALLATION INSTRUCTIONS FOR COMPLETE INFORMATION REGARDING THE LIMITATIONS OF THE ENTIRE SECURITY SYSTEM.



**ALARM DEVICE MANUFACTURING CO.**

A DIVISION OF PITTPWAY CORPORATION

**165 Eileen Way, Syosset, New York 11791**

Copyright © 1995 PITTPWAY CORPORATION