

No. 515 HOME ALARM

1. Mount the Control Box in the vicinity of the doors and windows that are to be protected. Mount an open-circuit switch on each door and window. (An open-circuit switch is one whose contacts are closed when the switch is not engaged). Ademco No. 39-2 Magnetic Contacts are recommended.
2. A lock switch is required to turn the burglar alarm on or off. The lock switch may be mounted in the hole provided on the side of the alarm unit (Use an Ademco No. 99 Lock Switch) or may be mounted on or near the exit door (Use an Ademco No. 3039 or No. 2274 Lock Switch).
3. Run a two conductor wire from Terminals 5 and 6 of the alarm unit to the contacts as shown in the diagram. On Ademco No. 39-2 contacts make connections to the Terminals marked COM. and N.C. The wire used for this run should be No. 18 Gauge, or heavier.
4. Wire the Lock Switch to Terminals 3 and 4. Use no more than 30 feet of No. 16 two-conductor to connect the lock switch to the alarm unit.
5. Connect the two wires (Red & Black) in the Control Box to a 6 volt battery, Ademco No. 866. Polarity must be observed - Red is positive - Black negative. If operation from A.C. is desired, add an Ademco No. 89 Energy Pack, or rechargeable power supply.
6. If an outside bell is desired, connect any Ademco underdome bell to terminals 1 and 2 using No. 16 wire. Keep the bell as close to the alarm unit as possible.

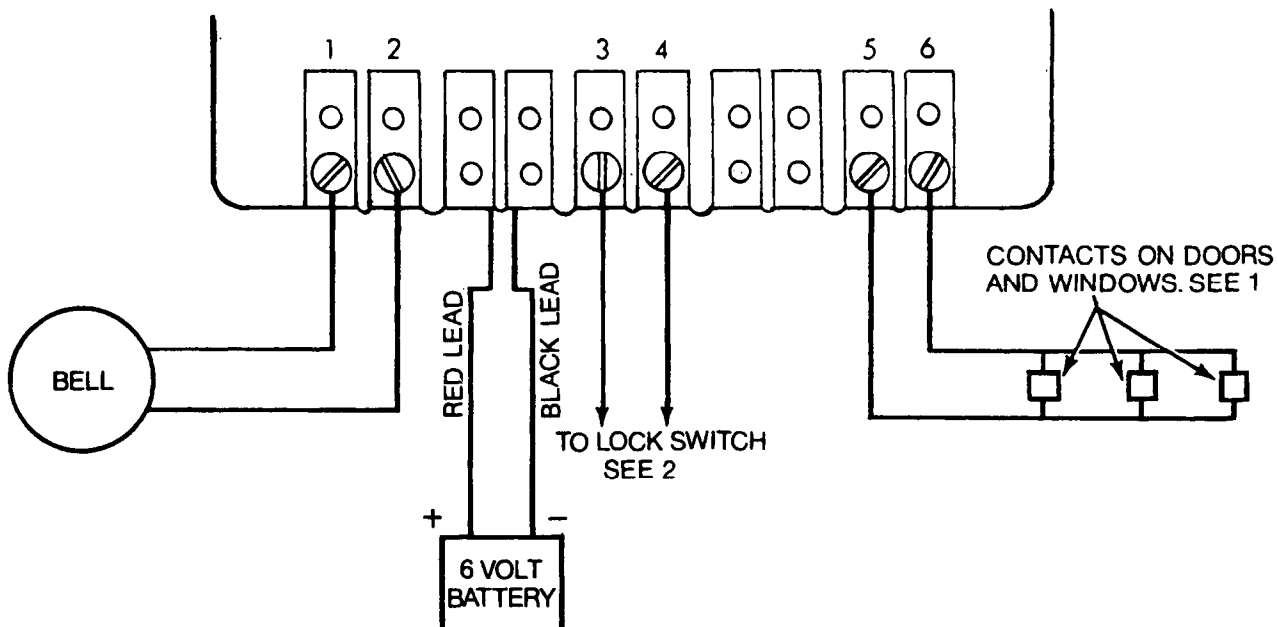

TROUBLESHOOTING No.515

TROUBLE: 1. BELL(S) DOES NOT GIVE FULL SOUND.

<u>PROBABLE CAUSE</u>	<u>REMEDY</u>
A. <u>Bell line does not conform to specified procedures.</u>	A. <u>See note at the end of this section. Also see Part I, Section G of this manual.</u>
B. <u>Low battery voltage or power supply output.</u>	B. <u>Replace battery or charge power supply if voltage measures substantially less than 6 volts while bell is operating.</u>
C. <u>Improper bell mounting.</u>	C. <u>Inspect mounting and bell dome position.</u>
D. <u>Short circuit in wires leading to bell.</u>	D. <u>Replace wires to bell, being careful to avoid conditions that will cause short circuits.</u>
E. <u>Short circuit in coil of latching (drop) relay (located above terminals 1 and 2--see Part I, Section H).</u>	E. <u>Replace drop relay.</u>
F. <u>Defective bell. If possible, test with new bell.</u>	F. <u>Replace bell.</u>
G. <u>Dirty or corroded keyswitch contacts.</u>	G. <u>Replace keyswitch.</u>

TROUBLE: 2. BELL CIRCUIT DOES NOT LATCH. WHEN THE CONDITION CAUSING ALARM IS CORRECTED, THE BELL STOPS EVEN THOUGH THE KEYSWITCH REMAINS ON.

<u>PROBABLE CAUSE</u>	<u>REMEDY</u>
A. <u>Dirty contacts on latching (drop) relay (this is the relay above terminals 1 and 2).</u>	A. <u>Clean relay contacts with burnishing tool, and/or spray (see catalog Nos. 316 and 317).</u>
B. <u>Open circuit in coil of latching (drop) relay.</u>	B. <u>Replace relay.</u>

TROUBLE: 3. BELL DOES NOT OPERATE WHEN THE PROTECTIVE CIRCUIT IS TRIPPED.

<u>PROBABLE CAUSE</u>	<u>REMEDY</u>
A. <u>Dirty contacts on protective circuit (sensitive) relay (this is the relay located above terminals 5 and 6).</u>	A. <u>Clean relay contacts with burnishing tool and/or spray (see catalog Nos. 316 and 317).</u>

<u>PROBABLE CAUSE</u>	<u>REMEDY</u>
B. <u>Stuck contact in protective circuit failing to make on break-in.</u>	B. <u>Check each contact for continuity when activated.</u>
C. <u>Disconnected or defective bell battery or power supply (recharge power supply for 24 hours if voltage measures less than 6 volts on alarm).</u>	C. <u>Check connections of bell battery or power supply to red and black flying leads of control. Replace battery if voltage reads less than 6 volts.</u>
D. <u>Disconnected or broken wires between relay panel and bell.</u>	D. <u>Check wiring and repair or replace as needed.</u>
E. <u>Defective keyswitch.</u>	E. <u>Replace keyswitch.</u>
F. <u>Bound bell clapper.</u>	F. <u>Free or adjust bell clapper. If necessary, replace bell.</u>

TROUBLE: 4. FALSE ALARMS OCCUR.

<u>PROBABLE CAUSE</u>	<u>REMEDY</u>
A. <u>Intermittent short (swinger) in one or more switch contacts.</u>	A. <u>With system armed, tap each contact to try to locate swinger. Replace as required.</u>
B. <u>Shorts in wiring going to contacts or shorts between terminals 5 and 6 at control.</u>	B. <u>Inspect wiring from terminals 5 and 6 throughout route to last contact. Repair any weak spots which may cause shorts to occur.</u>

TROUBLE: 5. BELL SOUNDS WHENEVER KEYSWITCH IS TURNED ON.

<u>PROBABLE CAUSE</u>	<u>REMEDY</u>
A. <u>A contact in the protective circuit is closed (normal operation requires that contacts only "make" on alarm).</u>	A. <u>Check all entry points to see that no windows or doors, etc. have been left ajar. Tap magnetic contacts to alleviate a sticking condition. Replace those found to be sticking.</u>
B. <u>Sticking contacts on panel latching relay (located above terminals 1 and 2).</u>	B. <u>Visually inspect relay contacts and clean and burnish if possible. Otherwise replace relay.</u>

NOTE: WIRE RUNS FOR BELLS OR OTHER SOUNDING DEVICES

For runs of up to 50 feet, use 16 gauge wire.

For runs between 50 and 100 feet, use 14 gauge wire, or preferably double 16 gauge wire (thus having four wires going to the sounding device).

For wire runs of over 100 feet, see Part I, Section G of this manual.