



# INSTALLATION INSTRUCTIONS

**Type 972  
LATCHING MONITORS**  
using  
**TYPE 985 & 986  
LATCHING SENSORS**

TABLE A: MODEL DESIGNATIONS		
Cat. No.	Description	Color
972WH	Latching Monitor	WHITE
972BR	Latching Monitor	BROWN
985WH	Latching Sensor	WHITE
985BR	Latching Sensor	BROWN
986WH	Multisensor Latch	WHITE
986BR	Multisensor Latch	BROWN

## INDEX:

### Sections:

	Page
GENERAL INFORMATION .....	1
DESCRIPTION .....	1
Type 972 Latching Monitors .....	1
Type 985 Latching Sensors .....	2
Type 986 Multisensor Latches .....	2
INSTALLATION AND WIRING .....	2
Preliminary Considerations and Sensor Location .....	2
Installation Procedure .....	3
TESTING AND ADJUSTMENT .....	3
GENERAL SPECIFICATIONS .....	4
Dimensional .....	4
Electrical .....	4

### Tables and Diagrams:

TABLE A: MODEL DESIGNATIONS .....	1
TABLE B: COVERAGE AND SENSITIVITY ADJUSTMENT GUIDELINES .....	4
Diagram 1: LATCHING SENSOR, TIME PULSE INTEGRATOR SHOCK RESPONSE .....	5
Diagram 2: LATCHING SENSOR, INSTALLATION DETAILS .....	5
Diagram 3: SENSORS FOR USE WITH TYPE 986, INSTALLATION DETAILS .....	6
Diagram 4: TYPICAL SENSOR LOCATIONS .....	6
Diagram 5: FIELD CONNECTIONS, WITHOUT SEPARATE TAMPER LOOP .....	7
Diagram 6: FIELD CONNECTIONS, WITH SEPARATE TAMPER LOOP .....	7

## GENERAL INFORMATION:

The Inertia Crossbar System Type 972 Latching Monitors accommodate any combination or quantity of Type 985 Latching Sensors or 986 Multisensor Latches (although a maximum of 30 is recommended for ease of servicing). The resultant forced entry (shock) detection system can be used alone or can complement other forms of perimeter protection. The system possesses the ability to detect attacks **before** an intruder gains entry to the premises. (See Table A).

Each sensor's sensitivity can be individually set and will respond to blows applied to the surface area that it protects. A succession of small shocks, a smaller number of larger shocks or a single gross attack will trip and latch the sensor and in turn trip and latch the monitor and place it in alarm. A fault in the sensor loop will also trip the monitor. A lit LED on the monitor and on each tripped sensor indicates that an alarm has occurred.

The monitor's alarm contacts can be connected to any alarm panel possessing a closed circuit loop. Reset is accomplished by interrupting the monitor's power momentarily.

## DESCRIPTION:

### Type 972 Latching Monitors:

Each monitor is furnished in a tampered housing containing an LED (visible through the unit's cover), an alarm relay and terminals for connection of: a) Two wire supervised sensor circuit with end-of-line resistor, b) separate tamper loop (if required), c) protective circuit (the unit's closed contacts open during alarm), d) 6-14V DC power.

When a sensor's trip level is reached and the monitor in turn trips, the monitor's alarm contacts will open and its LED will light. The unit will remain in alarm until reset by momentary interruption of power.

## TYPE 985 LATCHING SENSORS:

Each sensor's tampered housing contains a shock sensing module, a "trip level" (sensitivity) adjustment potentiometer and terminals for connection of the two wire, end-of-line resistor supervised sensor loop and (if required) a separate tamper loop. The housing is designed for surface mounting. An LED is visible through its cover.

The 985 Latching Sensor's terminal blocks are removable. This allows connections to be made in a less confined space. When replacing the wired block the wires should be carefully dressed to avoid interference with the cover LED, tamper switch or other components on the circuit board.

Each sensor contains a "time/pulse integrator" processing circuit which has been designed for optimum response to attempts at forced entry through most building materials. See Diagram 1. The alarm trip level is reached after the sensing of a succession of light shocks (e.g.: gentle prying of a door or window) or a smaller number of heavier shocks (e.g.: hitting or pounding on the building structure). A gross attack (very large single shock including breaking of glass) or fault in the sensor loop will trip the system **immediately**. The time/pulse integrator circuit provides immunity to lower level **occasional** shocks caused by building expansion or contraction, or other transient occurrences.

The sensing module may be rotated up to 180° about its axis to facilitate mounting on a vertical, horizontal or sloping surface and to enable sensor operation in a NORMAL or DAMPED mode, depending upon range desired, characteristics of the mounting surface and other field conditions. See Diagram 2.

At the heart of the sensing module is the inertia crossbar assembly. A high inertia mass is mounted on a highly polished gold plated "crossbar" which straddles four other highly polished gold plated elements in such a manner as to provide two parallel paths for the sensor circuit current, with two sensing/contact points in each path. Optimum long term stability and reliability are provided by this multiple path arrangement.

Forced entry attempts typically produce vibrations which affect the contact points of the sensing module's inertia crossbar assembly. The resultant tiny and rapid variations in sensor circuit current are then processed by the sensor's time/pulse integrator. If a series of shocks of sufficient intensity is sensed, the trip level will be reached, the unit will trip and its LED will light steadily. The monitor's system LED will light and the alarm will be signaled to the protective system control.

## TYPE 986 MULTISENSOR LATCHES:

The Type 986 contains processing circuits similar to those of the 985. It is also designed to accept an unlimited number of 981 or 983 ICS sensors in addition to its own sensing module, and report attack on any one (or more) of them. The 986 will latch (and report an alarm to the 972) when any of the sensors connected to it causes the trip level to be exceeded. Since there is only a single trip level adjustment for the entire group of sensors, all the sensors should be mounted on the same type of surface in the same vicinity so that one adjustment is optimum for all, and they have approximately the same diameter of protection. The 986 reports the status of the entire group, but can not register which sensor was attacked. For ease of servicing, a maximum of 20 sensors are recommended for connection to a single 986 and a total of 30 sensors to a single 972 (SEE DIAGRAMS 2 and 3).

## INSTALLATION AND WIRING:

### Preliminary Considerations and Sensor Location:

Because of the many types of building materials and construction methods used, it is impossible to give precise sensor location information for any shock system. Table B gives general guidelines for the diameter of protection (DP) that might be obtained under ideal conditions for each sensor when mounted on various materials and adjusted as shown.

Any number of sensors may be connected to a single monitor but a maximum of 30 is recommended for better operation and ease of servicing.

1. **The diameter of protection (DP) may be smaller where there are discontinuities in the mounting surface, such as windows, doors, corners or joints between panels or cracks.** In these cases, the sensors should be mounted at 1/2 DP from the center of the gap. See Diagram 4 (a,b,c,d). Where the opening exceeds the DP, use sensors around the edge as shown in Diagram 4(e).
2. **Locate sensors at the most likely intrusion height relative to outside ground level.** Where the height of the wall exceeds 1-1/2 DP, use two rows, staggered as shown in Diagram 4(f).
3. **Sensors on surfaces below outside ground level require half DP spacing.**
4. **Loose or rattling surfaces may give false shock signals.** In particular, check windows for loose frames or panes.
5. **Beams, studs and electrical conduit increase shock transmission.** For example, when protecting roof areas, take advantage of the shock transmitting properties of beams.
6. **Sensors on window frames should be located 2" or less from glass.**
7. **Sensors on glass should be located at least 3" in from the frame.** See Installation Procedure, Step 4b for mounting information.
8. **If zone annunciation of individual sensors is desired at the monitor's location, a Type 973- ( ) Zone Latching Monitor (with 5, 15, or 25 zone LEDs) is available for annunciation of Type 985 Latching Sensors and/or 986 Multisensor Latches.**

## Installation Procedure:

1. **Mount the monitor** either near the main protective system's control panel or within it (double sided foam tape can be used).
2. **Run wiring between the control panel, monitor and sensor locations** as indicated in Diagram 5 or, if a separate tamper circuit is desired, Diagram 6.

Use of twisted wiring is recommended for the sensors to minimize the possibility of picking up unwanted induced voltages.

3. **Make connections to the monitor as indicated in Diagram 5 or 6 but DO NOT CONNECT DC VOLTAGE TO THE MONITOR** until the sensors have been installed and all other connections have been made.

**Note:** The reset switch shown in Diagram 5 and 6 is not required if the voltage is otherwise interruptible for reset.

4. **Mount and connect the sensors.**

- a. **Remove the cover** by releasing the screw on its face.

- b. **Mount the backplate** via the three mounting holes provided. **IMPORTANT:** The backplate must be in close contact with the mounting surface. Where the surface is unavoidably rough, make sure that high points are close to and touching the area behind the sensing module.

The sensors may also be mounted using double sided foam tape (not thicker than 1/16") on firm surfaces (e.g., glass, stone, etc.).

**Note:** Sensors must be installed so that the axis of the sensing module is **horizontal**, whether the unit is mounted on a vertical, horizontal or sloping surface (see Diagram 2).

- c. **Rotate the sensing module** until the line on its end is vertical, with the N (normal) or D (damped) position uppermost (see Diagram 2).

**Note:** The damped mode is useful on "problem" surfaces that are exposed to public areas or other possible sources of unwanted vibration.

- d. **Make connections as indicated in Diagram 5 or 6.** Be sure to install the end-of-line resistor at the last sensor. Replace sensor covers.

5. **Connect the required DC voltage to the monitor.** Observe polarity! Incorrect polarity could blow the fuse or trip the circuit breaker in the power source.

The voltage should be provided from a source that can supply 40 mA at 6-14V DC and that has at least 4 hrs. standby in the event of AC power failure.

6. **Proceed with TESTING AND ADJUSTMENT.**

## TESTING AND ADJUSTMENT:

With the required DC voltage applied to the monitor and the sensor loop closed, the monitor's LED should be off and its alarm contacts should be closed. In addition, all sensors' LEDs should be off.

**Note:** If the tampers have been connected in the sensor loop (Diagram 5), the monitor cover and all sensors' covers must be in place (or the tamper terminals temporarily shorted).

1. **At the first sensor in the loop, open the sensor loop momentarily** (**Note:** If the tampers have been connected in the sensor loop, the loop will be automatically opened by the releasing of the monitor's tamper switch upon the removal of the monitor cover). The monitor's LED should light steadily and its alarm contacts should open.

2. **Remove a sensor cover and turn the arrow on the sensor's sensitivity adjustment pot. to the suggested initial setting range indicated in Table B** for the type of surface being protected by the sensor. Replace the cover, if the sensor's tamper switch is in the sensor loop.

3. **Tap the area near the sensor with a hard object** (such as a screwdriver handle or small hammer) about once per second until the sensor's alarm trip level is reached and its LED lights.

The monitor's LED will light and its alarm relay contacts will open. Reset the system. **Note:** If the tampers are in the sensor loop, reset can be accomplished **at the sensor** by simply removing the sensor's cover momentarily to open (release) the tamper.

Repeat the tapping test several times at different points near the sensor.

As explained earlier, if the sensor is properly adjusted to respond to a succession of small shocks and/or a smaller number of larger shocks it also responds to a very large "gross" attack.

If necessary, adjust the sensor's sensitivity pot. (clockwise to increase sensitivity, counterclockwise to decrease) until desired results are obtained. The pot.'s final setting does not necessarily have to be within the initial setting range indicated in Table B.

If the sensor is overly sensitive while operating in the NORMAL (N) mode, it may prove desirable to orient its sensing module in the DAMPED (D) mode and readjust its sensitivity pot. accordingly. Conversely, a sensor with low sensitivity while in the DAMPED (D) mode may require operation in the NORMAL (N) mode.

4. **Repeat Steps 2 and 3 for each sensor and replace all covers.**

# GENERAL SPECIFICATIONS:

Dimensional:	972	985	986	983
Width:	2 1/8" (5.4 cm)	1 1/2" (3.8 cm)	2 1/8" (5.4 cm)	1 1/2" (3.8 cm)
Height:	3 3/4" (8.3 cm)	2 1/2" (6.4 cm)	3 3/4" (8.3 cm)	2 1/2" (6.4 cm)
Depth:	1 1/8" (2.8 cm)	1 1/8" (2.9 cm)	1 1/8" (2.9 cm)	1 1/8" (2.9 cm)
	<b>981</b>			
Diameter:	7/8" (2.2 cm)			
Depth:	1 1/4" (3.2 cm)			

## Electrical:

### 972 MONITOR

Input Voltage: 6-14V DC  
 Input Current: 40 mA standby  
 15 mA (max) additional for each tripped sensor.

Alarm Contacts: SPST, 1.0A, 28 VDC, 20W (max. ratings)  
 Tamper Contacts: 0.1 A, 28 VDC (max. ratings)  
 Sensor Loop: 60 ohms permissible resistance  
 (plus 1K ohm end-of-line resistor)

### 983 SENSORS

Tamper Ratings: 0.1 A, 28 VDC (max. ratings)

### 986 LATCHING SENSORS

Tamper Ratings: 0.1 A, 28 VDC (max.)  
 Input Current: 15 mA

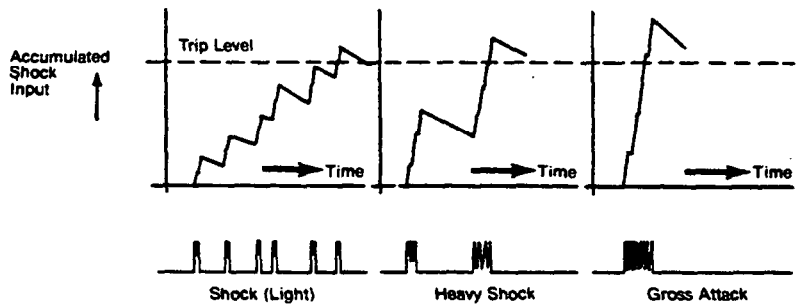
### 985 LATCHING SENSORS

Tamper Ratings: 0.1 A, 28 VDC (max.)  
 Input Current: 15 mA

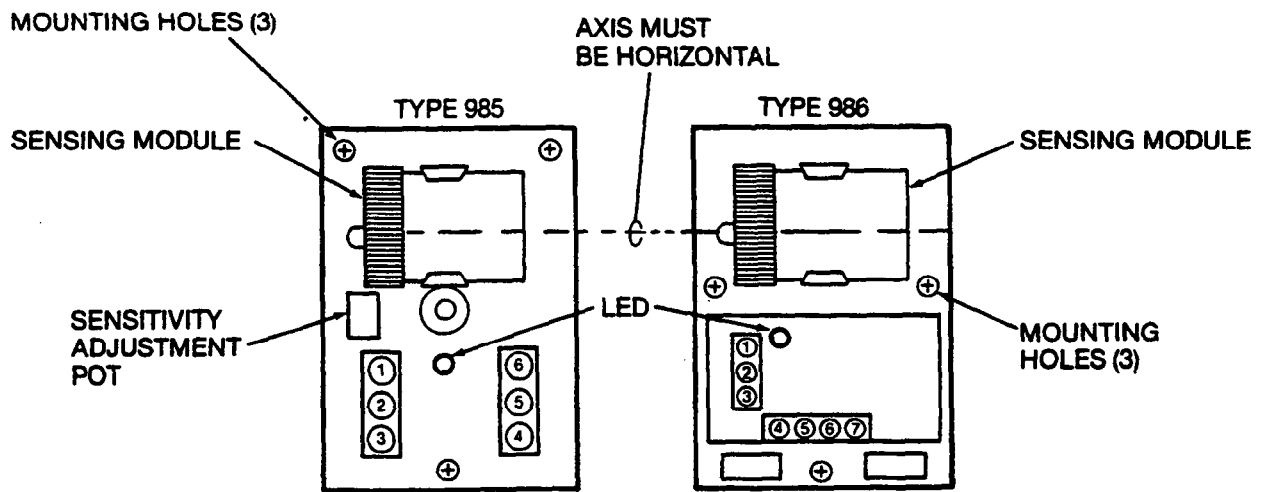
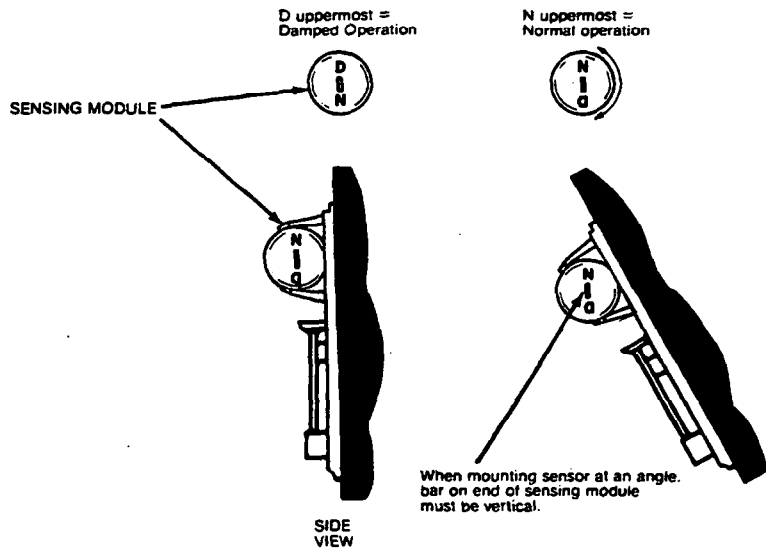
**\*TABLE B** COVERAGE AND SENSITIVITY ADJUSTMENT GUIDELINES

SENSITIVITY POT SETTING RANGES	MATERIAL	DIAMETER OF PROTECTION (DP)		"GROSS ATTACK" SENSITIVITY POT. SUGGESTED INITIAL ADJUSTMENT "O'CLOCK" SETTING RANGES (SHADED AREAS)
		NORMAL (N) MODE	DAMPED (D) MODE	
<b>A</b> (LOW)	Heavy Metal	15 ft	9 ft	
	Sheet Metal	10 ft	7 ft	
<b>B</b> (LOW INTERMEDIATE)	Plate Glass	12 ft	8 ft	
	Wood Paneling	8 ft	6 ft	
	Hardboard	8 ft	6 ft	
<b>C</b> (HIGH INTERMEDIATE)	Multi-Pane Glass	10 ft	7 ft	
	Plaster Board	8 ft	5 ft	
<b>D</b> (HIGH)	Concrete Block (Hollow)	12 ft	8 ft	
	Cinder Block (Hollow)	12 ft	8 ft	
	Concrete (Solid)	10 ft	7 ft	
	Cinder Block (Solid)	10 ft	7 ft	
	Brick	9 ft	6 ft	

**\*IMPORTANT:** This table is for guidance and comparison only. Actual coverage obtained and final sensitivity pot. setting required will vary because of differences in materials, construction methods and other field connections and will not necessarily fall within the boundaries shown here.

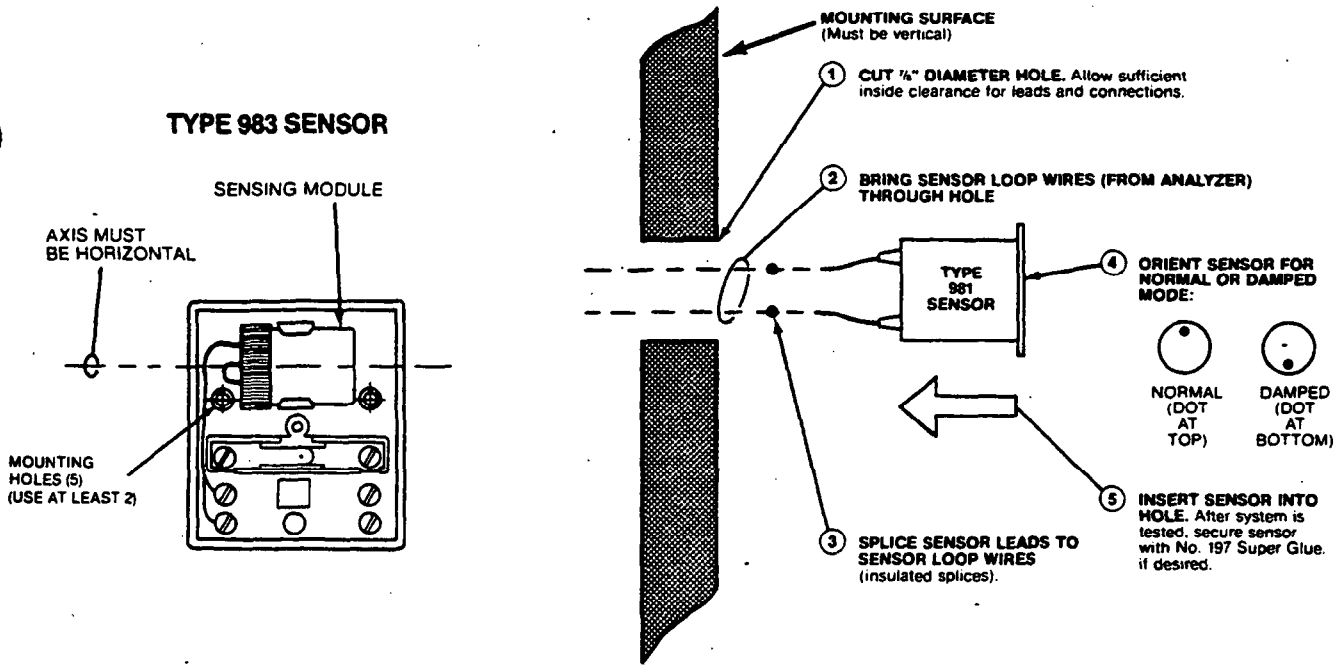


**Diagram 1: LATCHING SENSOR TIME/PULSE INTEGRATOR SHOCK RESPONSE**

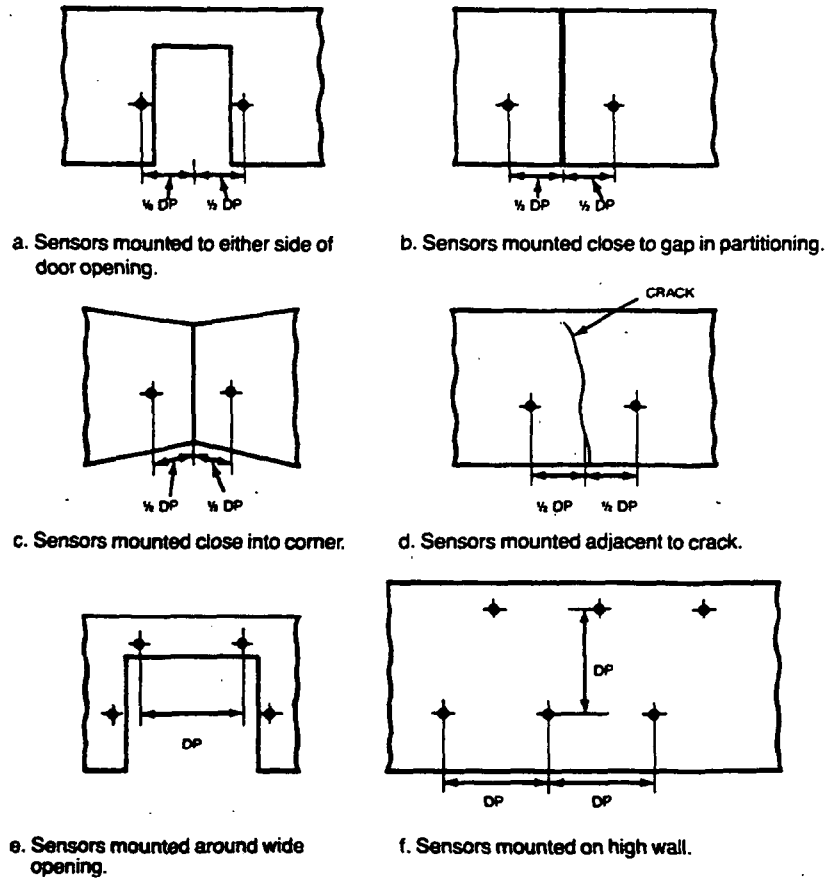


**Diagram 2: LATCHING SENSOR INSTALLATION DETAILS**

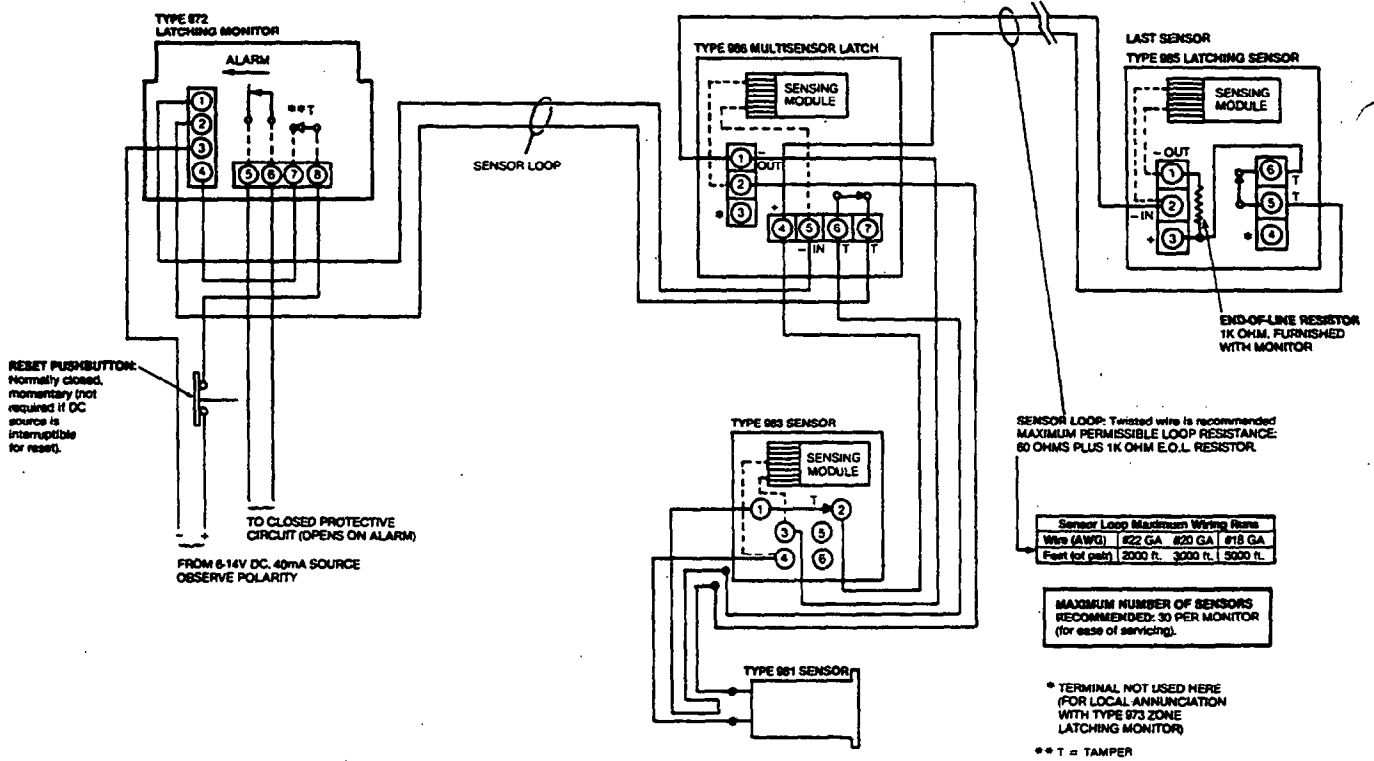
### TYPE 981 SENSOR



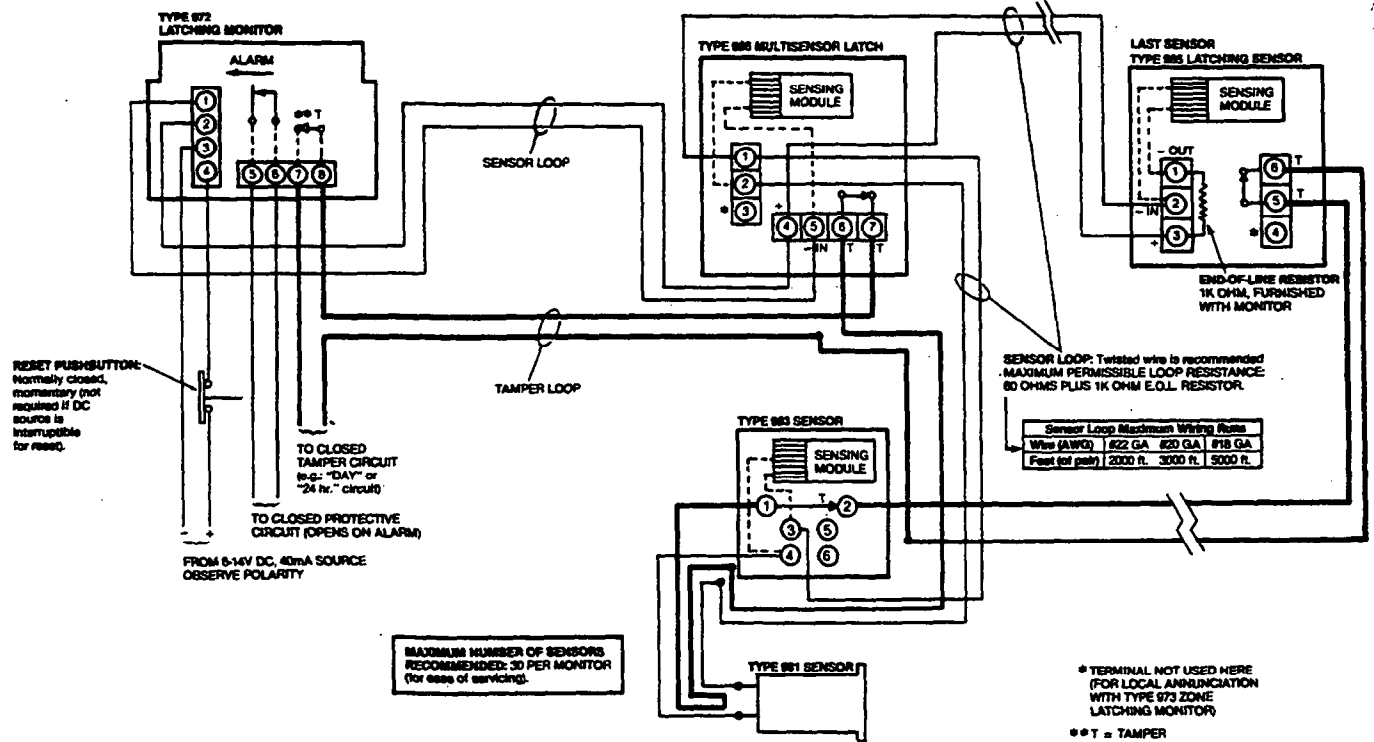
**Diagram 3: SENSORS FOR USE WITH TYPE 986 INSTALLATION DETAILS**



**Diagram 4: TYPICAL SENSOR LOCATIONS**



**Diagram 5: FIELD CONNECTIONS WITHOUT SEPARATE TAMPER LOOP**



**Diagram 6: FIELD CONNECTIONS WITH SEPARATE TAMPER LOOP**