

### GENERAL INFORMATION:

The No. 688-12 Opening/Closing Switching Module is designed for interfacing between an alarm processing center (or any other equipment) with a 12V. DC electronic output and a digital communicator, to signal the communicator to send opening and closing messages as the control is disarmed and armed. It permits such an electronic input to control a higher energy output load.

12V. alarm processing centers such as the 1022-12 and 1025-12 may be used, regardless of the method used to arm and disarm the system.

Any 6V. to 12V. DC activated digital communicator with "restore" or "open/close" message capability may be used (e.g. No. 669 or 678).

When connected as described herein, the No. 688-12 provides a 12V. DC continuous output signal while the control is armed ("night" position) and zero output while the control is disarmed ("day" position). Reversed output connections are also possible: zero output while armed and 12V. DC output while disarmed.

Diagram 1 explains the relationship between the input and output voltages.

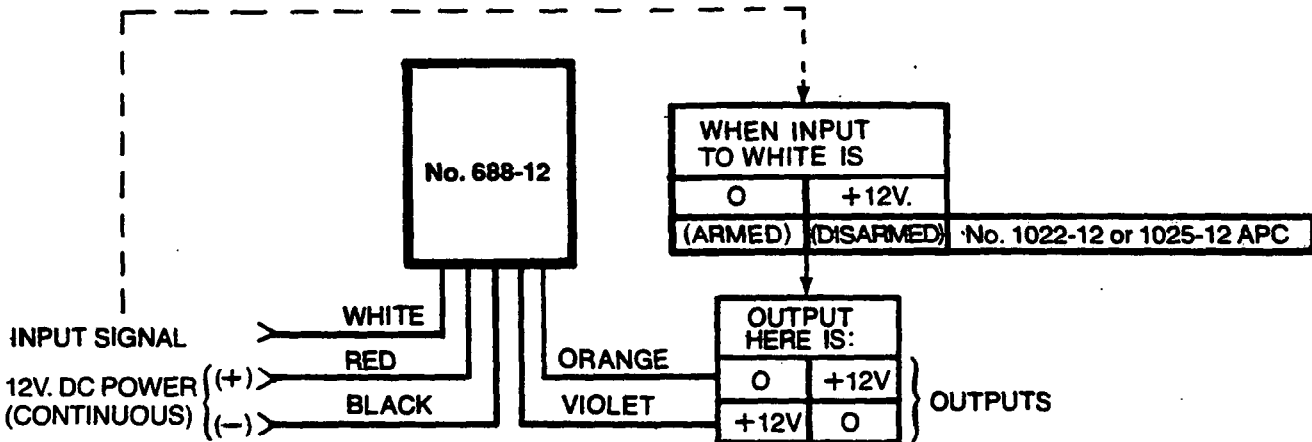

Diagram 1: INPUT/OUTPUT RELATIONSHIPS

The No. 688-12 can also be used to energize a relay to turn lights on at entry time (for instance). See OTHER APPLICATIONS herein and Diagram 3.

### INSTALLATION AND WIRING:

1. Disconnect the control panel's battery and A.C. power.
2. Install the No. 688-12 in the control panel's cabinet. A mounting lip is provided on the No. 688-12 which can be slipped over the cabinet's edge without interfering with the closing of the cabinet's cover.
3. Run wiring and make connections to the particular control and communicator to be used, as indicated in Diagram 2.
4. Reconnect the power sources disconnected in Step 1 and check the operation of the digital communicator with the central monitoring station when the system is armed and disarmed.

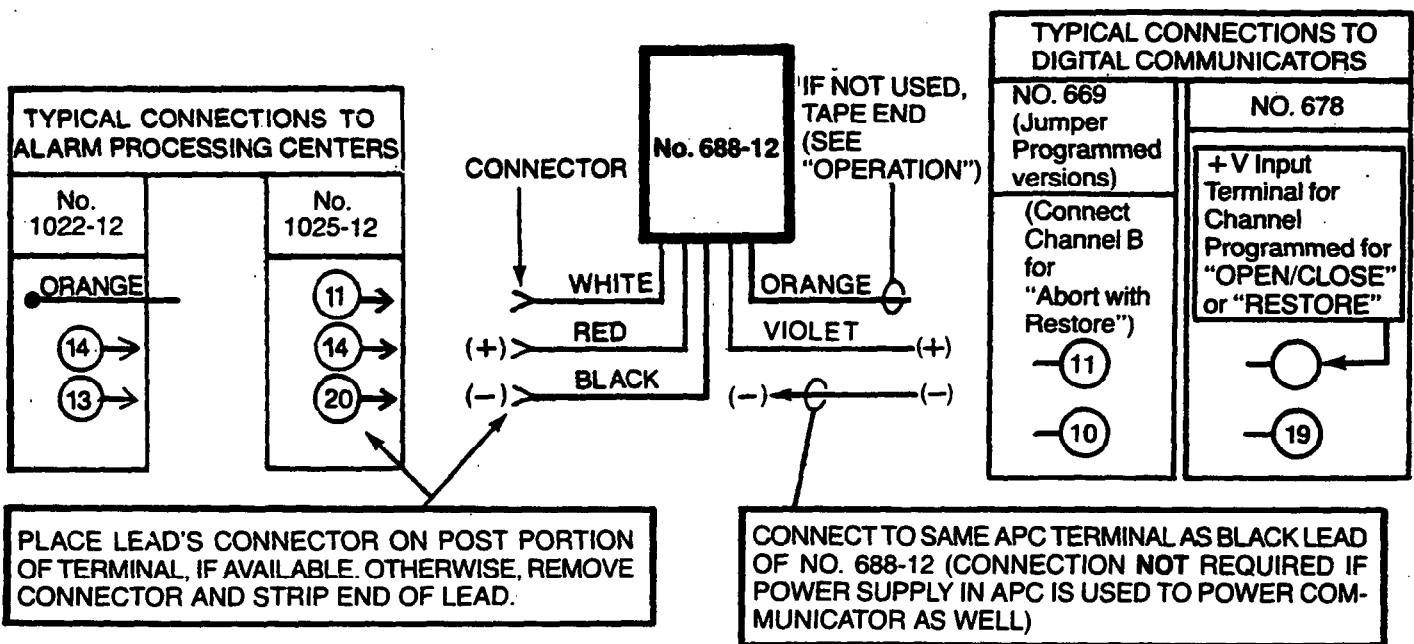

Diagram 2: TYPICAL CONNECTIONS FOR OPENING/CLOSING SIGNALS FROM APC'S

## OPERATION:

When the control panel is **ARMED**, the communicator will send its programmed message as the "closing" signal. With the No. 669, its Channel B PROGRAMMED CODE will be sent. With the No. 678, the OPEN/CLOSE or RESTORE channel # will be sent, as selected.

When the control panel is **DISARMED**, the communicator will send its RESTORE (or OPENING) message as the "opening" signal. For the No. 669, a "9" or "7", as chosen, will be sent. For the No. 678, a "9" will be sent for an OPEN/CLOSE channel. The channel # and then a "9" will be sent for a RESTORE channel.

**Note:** If the No. 688-12's ORANGE lead is connected to the communicator in lieu of the VIOLET lead, operation will be reversed. For a No. 669 communicator, for example, **ARMING (CLOSING)** will send the RESTORE CODE and **DISARMING (OPENING)** will send the PROGRAMMED (Channel B) CODE.

It should be noted that a No. 1022-12 Alarm Processing Center can provide such operation **without** use of the No. 688-12. The No. 1022-12's installation instructions describe how to connect the APC's ORANGE lead directly to a No. 669 digital communicator for opening (Programmed Code) and closing (Restore Code) signals.

## OTHER APPLICATIONS:

The No. 688-12 can also be used to control a load (minimum resistance: 500 ohms) such as a relay. The load may be connected between the ORANGE or VIOLET lead and the negative (-) side of the power supply. Both leads may be connected to a load (one will be ON while the other is OFF). For example, Diagram 3 shows how an alarm processing center (such as the No. 1025-12) can be used to turn on lighting during the entry delay period.

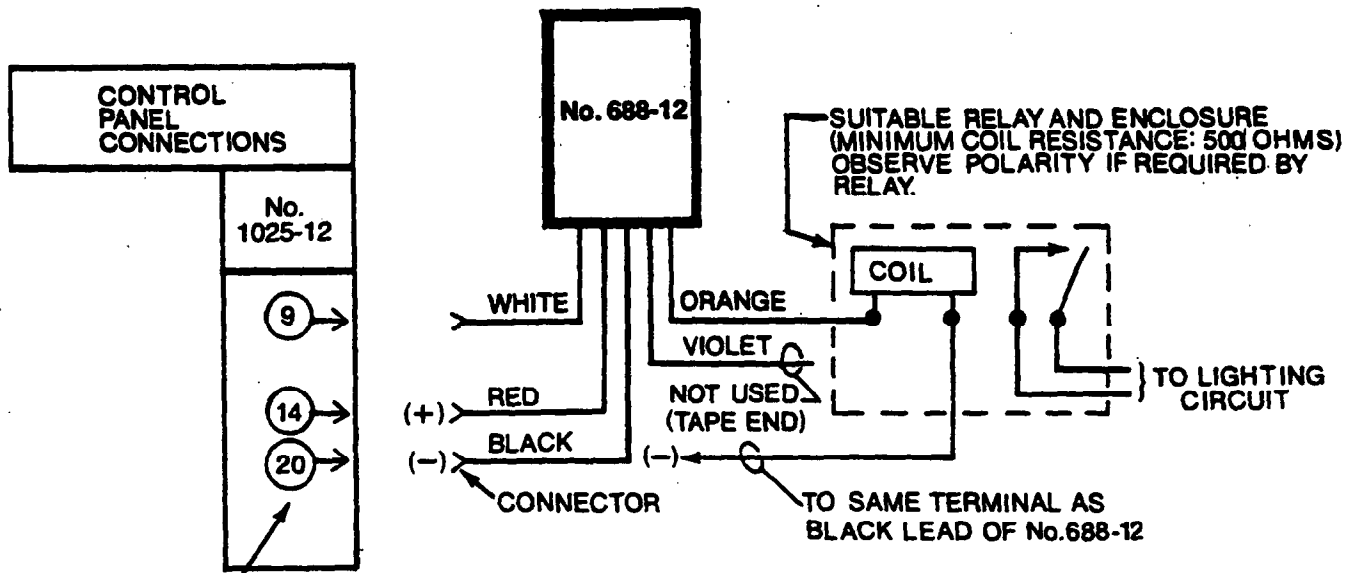

PLACE LEAD ON TERMINAL'S POST, IF AVAILABLE. OTHERWISE, REMOVE CONNECTOR AND STRIP END OF LEAD.

**Diagram 3: TO TURN LIGHTS ON DURING ENTRY DELAY PERIOD.**

### SPECIFICATIONS:

**Physical:** Length: 3" (7.6 cm)  
Width: 1 3/4" (4.4 cm)  
Height: 3/4" (1.9 cm)

**Electrical:** Powered from control (12V. DC)

**Input: (WHITE lead):**  
Resistance: 330K ohms  
Low ("Armed") Level: Zero (less than +0.4V)  
High ("Disarmed") Level": +12V (greater than +5V)

**Outputs:** VIOLET lead: Inverting (+12V when input is Zero)  
ORANGE lead: Non-inverting (Zero when input is Zero)

Loads should be connected to VIOLET and/or ORANGE lead and negative (-) of power supply. Minimum resistance of load: 500 ohms.