

ADEMCO
PROVED PERFORMANCE

INSTALLATION INSTRUCTIONS

**No. 659
LINE FAULT
MONITOR**

GENERAL INFORMATION:

The No. 659 Line Fault Monitor is designed to connect across incoming telephone lines on systems using telephone dialers (e.g. No. 612) or digital communicators (e.g. Nos. 669, 670 or 662). It will give a signal if the telephone line is cut or shorted or incoming service is otherwise interrupted. The signal can be the sounding of the protective system's alarm bell (when the system is ON) or the lighting of a trouble indication lamp (No. 664). A built-in delay of approximately 30 seconds prevents false alarms in the event of momentary outages of telephone service.

The No. 659 can also be used to control the selection of a telephone line when an alternate line is connected to the dialer or communicator.

OPERATION:

The No. 659 operates from 6 V.DC. This voltage may be from the power supply for the dialer or communicator or from a separate power supply.

Output Relay: Any condition (such as an open or short) that drops telephone line voltage to a value below 0.25 V.DC will energize the relay (after a 30 second delay) in the No. 659. (Individual units may trip at voltages slightly above 0.25 V. but the No. 659 will remain set as long as it senses at least 0.75 V.DC.)

The energizing of the relay can, at the option of the installer, be either:

- a. Momentary, where the relay will be energized for only about one second and then fall off. When the fault is cleared the monitor circuit will automatically reset and be ready for another one second energization should a fault reappear.

This option is normally used when the contacts of the relay are wired into the protective circuit of the control to sound the alarm.

or

- b. Maintained, for as long as the telephone line fault persists. When the fault is cleared the relay will automatically be de-energized.

This option may be used for special applications such as to sound an electronic siren when no alarm control panel is used. If it is desired to ring a bell, see the Output Relay caution note under SPECIFICATIONS.

Local Latching Indication: If desired, a No. 664 Digital Communicator Tester can be used with the No. 659 as a monitor lamp and reset switch to indicate whether the telephone line is or has been out of service. After approximately 30 seconds of the No. 659's sensing of a line fault, the LED (light emitting diode) indicator in the No. 664 will light and remain lit until the line fault has cleared and the No. 664's switch is depressed. This latching and reset action is independent of the output relay option chosen above.

Logic Level Signal: This output is for use with the No. 674 Select-A-Line (which permits a dialer or communicator to be used with two telephone lines for increased reliability of transmission). Information as to its use is provided with the No. 674.

INSTALLATION:

For ease of installation the No. 659 includes a ¹⁴⁹housing which allows it to be conveniently

mounted in a digital communicator (or other) cabinet. The No. 659's upper edge is provided with a lip that can be slipped over the edge of the cabinet without interfering with the ability of the cabinet's cover to close and lock. See Diagram 1.

WIRING:

See Diagram 1.

Some leads of the No. 659 are permanently wired to its circuit board. Other leads, with quick disconnect terminals, are packaged with the No. 659. These must be attached to connection posts on the unit, in the field, as required and as indicated in Diagram 1.

In either case, field wiring must be extended from these leads. Use wire nuts, solderless crimp terminals, or solder and tape where necessary.

Proceed with wiring as follows:

1. Ground: **IMPORTANT**: Connect a "quick disconnect" lead to the post provided (See Diagram 1) and extend to a cold water pipe ground. Grounding provides protection against externally induced transient voltages in the telephone lines and must be connected to insure reliable operation of the No. 659.
2. Output Relay Contacts: For normal connection to an alarm control with a supervised protective circuit, place quick disconnect leads on the N.C. and COM. posts provided and extend them to the positive leg of the protective circuit. For non-supervised systems, the N.O. and COM. posts should be used.

NOTE: Upon the sensing of a telephone line fault by the No. 659, the output relay's COM. and N.O. contacts will close and its COM. and N.C. contacts will open, in accordance with the "Momentary" or "Maintained" Output Option Selected below:

- a. Momentary Output Option (output relay energized only for about one second during line fault duration): CUT BLACK JUMPER that protrudes from back of circuit board.
 - b. Maintained Output Option (output relay energized for duration of telephone line fault): LEAVE BLACK JUMPER UNCUT that protrudes from back of circuit board.
3. Local Latching Indication: If such indication is desired, extend the WHITE, ORANGE and BROWN pre-wired leads of the No. 659 to the WHITE, RED and BLACK leads respectively of a No. 664 Test Button with Monitor Lamp located where desired. Usually the location will be next to the alarm control panel so the No. 664's lamp will be seen, if lit, when the alarm system is being turned ON.
 4. Telephone: Connect the YELLOW and GREEN leads of the No. 659 across the incoming telephone pair (disregard polarity) which is connected to the dialer, digital communicator or No. 674 Select-a-Line (or elsewhere when specified).
 5. Logic Level Signal Post: Information on the use of this post in connection with telephone line selector units (such as the No. 674 Select-A-Line) is given with the particular unit to be used.
 6. 6 V.DC Power: Connect the RED (positive) and BLACK (negative) leads of the No. 659 to a 6 V.DC power supply such as: that of the digital communicator or dialer, a standard 6 V. lantern battery or one of Ademco's Recharge-A-Packs or other 6 V.DC power supplies.

MOUNTING LIP
(SEE DETAIL
AT RIGHT)

No. 659

COVER

CABINET

No. 659

MOUNTING DETAIL

BLACK "OUTPUT RELAY" JUMPER AT BACK OF
CIRCUIT BOARD
FOR MAINTAINED CLOSURE ON FAULT, DO NOT
CUT JUMPER
FOR MOMENTARY CLOSURE ON FAULT, CUT JUMPER

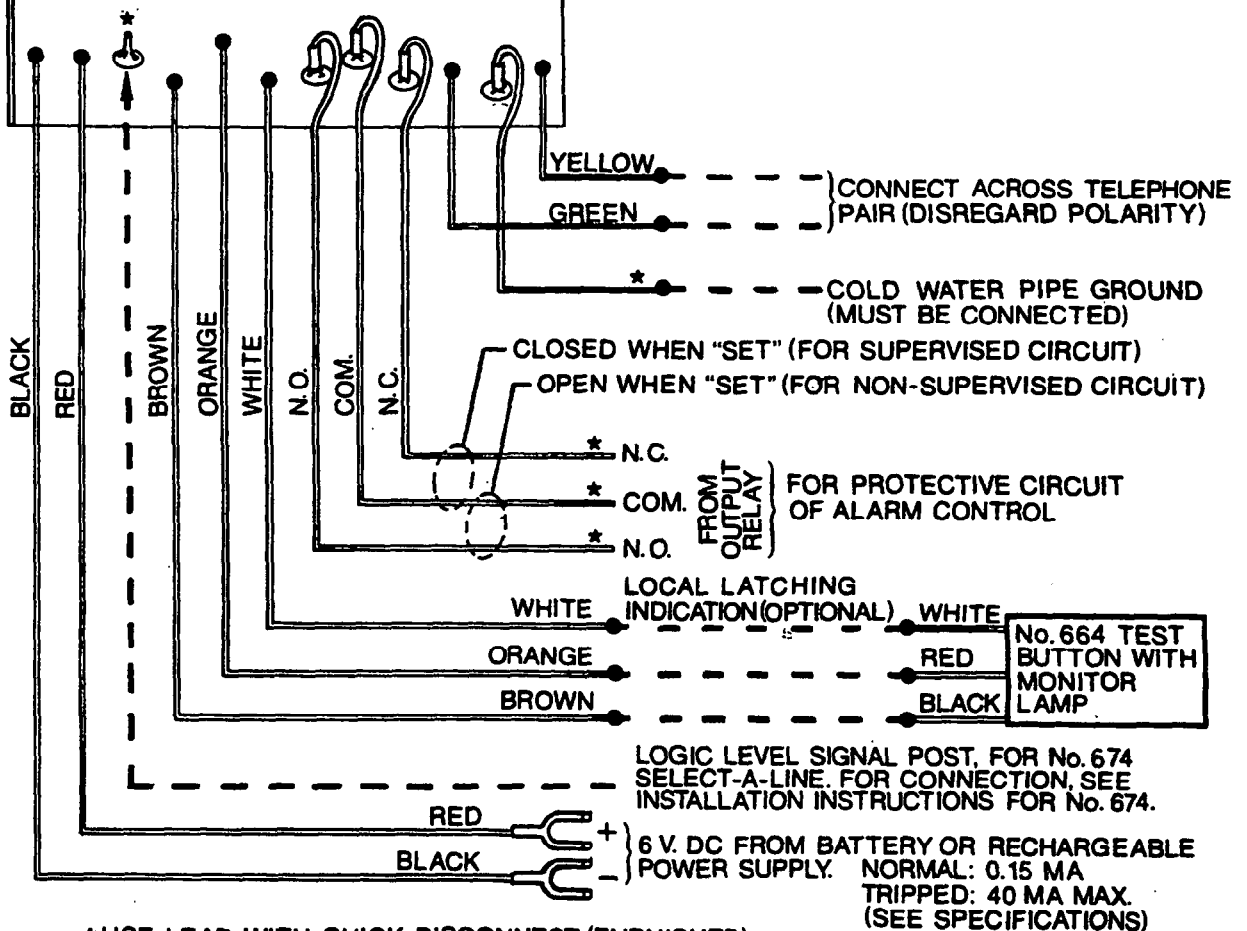

*USE LEAD WITH QUICK DISCONNECT (FURNISHED)

--- EXTEND AS REQUIRED

Diagram 1: Installation and Wiring

SPECIFICATIONS:

Physical:

Width: 2 1/2" (6.4 cm.)
Height: 6" (15.2 cm.)
Depth: 1 1/2" (3.8 cm.)

Weight: 8 oz. (226.8 grams)

Power:

Operating Voltage: 6 V.DC (from battery, Recharge-A-Pack or other 6 V.DC rechargeable power supply.)

Current Drain: *Standby, Telephone Line Intact: 0.15 ma.

*Telephone Line Fault, "Maintained" Output Option Selected: 30 ma.

*Telephone Line Fault, "Momentary" Output Option Selected: 0.15 ma.

*NOTE: If a No. 664 is used as a remote indicator, an additional 10 ma will flow when the indicator is illuminated.

Phone Line:

Sensed Voltage: All units will stay set at sensed telephone line voltages of 0.75 V.DC or more.

All units will trip when the sensed telephone line voltage drops to 0.25 V.DC or less for approximately 30 sec. or more.

Polarity: Insensitive to phone line polarity.

Input Impedance at Phone Line Terminals: Greater than 10 Megohms between lines.

Impedance between Telephone Lines and Ground or Battery: Greater than 100 Megohms, 1500 V. breakdown.

Output Relay: SPDT Contacts, 2 amp. max. (AC or DC)

Caution: If it is desired to ring a bell with these contacts, an intermediate relay should be used between the No. 659 and the bell so that pulsating bell current does not pass through the No. 659 and possibly cause interference with the latter's operation. (The No. 659, in compliance with FCC Regulations, incorporates a very high input impedance circuit which can be affected by the bell electrical noise.)



ALARM DEVICE MANUFACTURING CO.

A DIVISION OF PITTMAY CORPORATION

165 Eileen Way, Syosset, New York 11791

P3516 REV. B 8/80

Copyright © 1976 PITTMAY CORPORATION