



# INSTALLATION INSTRUCTIONS

**No. 5241-12**  
SELF-CONTAINED  
DIGITAL  
REMOTE STATION **A**

## for 12V Panels (such as the Nos. 1023-12, 1025-12, 1025EX12 Alarm Processing Centers)

### GENERAL INFORMATION

The No. 5241-12 Self-Contained Digital Remote Station has a 12 button keypad. It provides four digit coded ON/OFF (Arm/Disarm) control for 12V panels such as the Nos. 1023-12, 1025-12 and 1025EX12 Alarm Processing Centers. It connects directly to the control. No separate adapter is needed.

Panic alarms may be tripped from the keypad by momentarily pushing its buttons marked # and \* simultaneously or, if desired, from panic/emergency devices (momentary or locking type) located elsewhere in the protected premises.

The No. 5241-12 is intended for indoor use, within the protected premises. No more than one may be connected to the control. **When the No. 5241-12 is used, the keyswitch normally connected directly to the panel for ON/OFF control may NOT be used.**

Status of the control's burglar alarm circuitry ("not ready for arming", "alarm memory", "ready for arming" or "armed") is indicated by two LEDs (RED and GREEN) on the face of the unit.

A warning buzzer, included in each unit, is used in conjunction with the control's entry/exit delay zone and such other warning sounds as the control or its other accessories may provide (see instructions accompanying those units).

Circuit safeguards erase all prior information entered via the keypad to prevent alarm or disarming if more than 3 seconds are taken to enter the code.

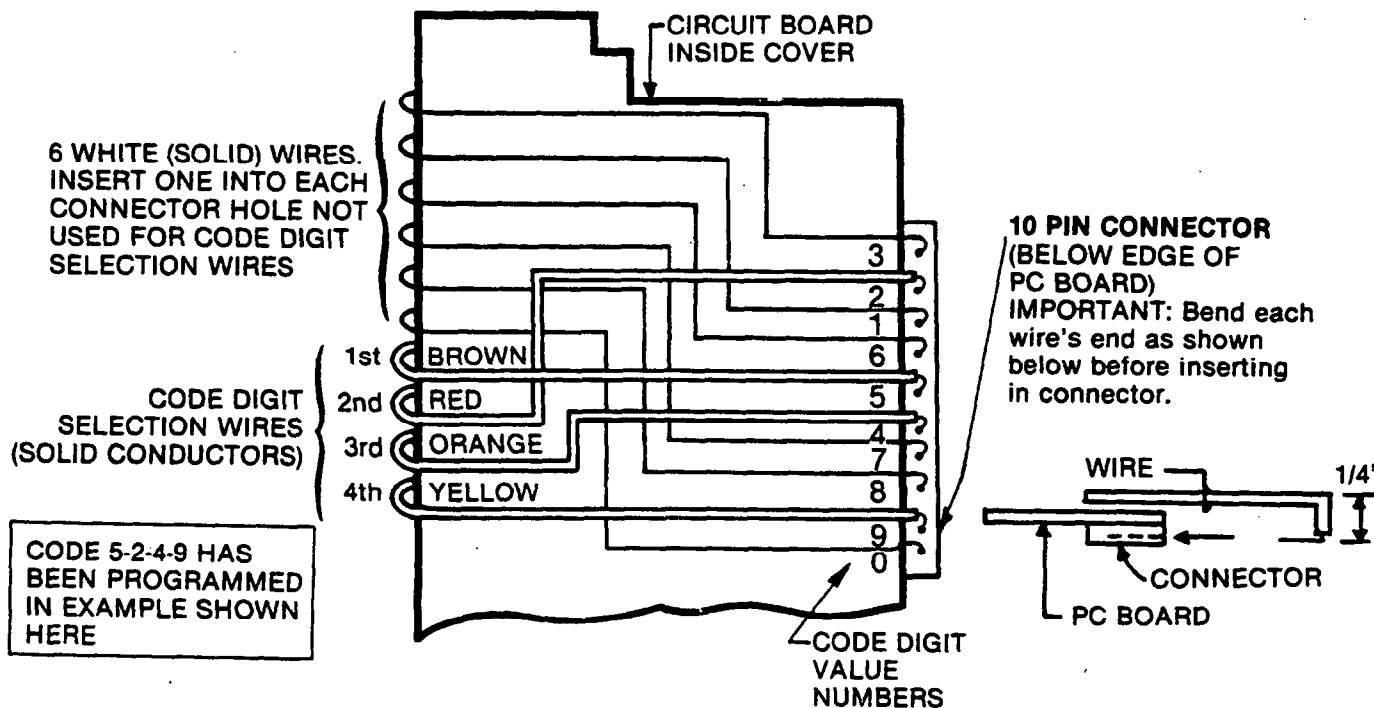

Diagram 1: CODE PROGRAMMING

### INSTALLATION AND WIRING:

1. Select a four digit arm/disarm code for the No. 5241-12 Remote Station. The code must contain 4 different digits (e.g.: 2-6-3-7). Digits may not be used twice.

2. **Program the No. 5241-12 for its assigned code, as follows** (Note: In the following example the No. 5241-12 is being programmed for code 5-2-4-9):
  - a. **Remove the unit's cover** and position it so that the circuit board within the cover appears as shown in Diagram 1.
  - b. **Observe the "Code Digit Selection Wires"**, the 4 inch solid conductor wires at the left side of the circuit board. The colors are BROWN, RED, ORANGE and YELLOW.
  - c. **Observe the 10 pin connector** below the right edge of the PC board. Its holes are associated with digit values of 0 through 9 as indicated in Diagram 1. Note that the holes are not numbered sequentially.
  - d. **Simply insert the BROWN wire in the connector hole which corresponds to the numerical value selected for the first digit** ("5" in Diagram 1's programmed example).
 

**Important:** To insure good contact, bend the end of each wire as shown in Diagram 1 before inserting it in the connector.
  - e. **Similarly insert the RED, ORANGE and YELLOW wires in the holes for the 2nd, 3rd and 4th digits respectively** ("2", "4" and "9" in Diagram 1's programmed example).
  - f. **Insert one of the six WHITE wires into each remaining connector hole** and dress all wires neatly down against the PC board.
  - g. **Replace the unit's cover** until ready to mount it in its selected location.
3. **Mount the No. 5241-12 in the desired location and run wiring** between it and the control as shown in Diagram 2. Total wiring distance should not exceed 400 ft. Do not connect the wiring to the control until Step 6.
  - a. **The No. 5241-12 is intended for surface mounting, WITHIN the protected premises. Concealed wiring may enter via a large square hole in the base of the unit. Breakaway knockouts are provided in the base for exposed wiring.**
  - b. **Where the Alarm Processing Center is to be used in a Cabinet which has a suitable cutout in its cover** (e.g.: No. 8208), the No. 5241-12 may be flush mounted directly on the Alarm Processing Center's cover. "Sandwich" the cabinet door between front and rear portions of the No. 5241-12 and secure with 2 screws.
4. **A switch for PANIC RESET is required** (N.O., momentary) if the No. 5241-12's panic feature is to be used. Suggested switches (may be cabinet mounted): No. 2174-70 (flat key), No. 4073-70 (round key), No. 5073-70 (higher security, pick resistant)...or simply a pushbutton such as the No. 8064 may be used. If a pushbutton is used it should be located within the Alarm Processing Center or in some other location where it is not in view.
 

Mount the switch and run wiring from it to the control panel (See Diagram 2) but do not connect the wires to the control until Step 6.

*Note:* The No. 5241-12's panic latching feature permits non-locking (momentary closure) panic/emergency switches, such as the No. 219, to be connected to the Alarm Processing Center for AUDIBLE PANIC alarm (ordinarily only locking type devices may be used). Any number of locking and/or non-locking devices may be connected in parallel. Run wiring from them to the control panel (see Diagram 2) but do not connect to the control until Step 6. (For SILENT PANIC alarm information see Step 6).

Up to 400 feet of #22 wire (total) may be used for the PANIC RESET and panic/emergency switch wiring.
5. **Disconnect the control's battery and AC power.**
6. **Connect the wiring to the control as shown in Diagram 2.**
  - a. **Note that panic/emergency device connections differ, depending on whether momentary contact (non-latching) or locking type devices are used.**
  - b. **If SILENT PANIC alarm is desired,** connection may be made to a digital communicator. Connect all leads shown on terminal 8 of the control in Diagram 2 instead to the positive (+) "triggering by voltage" (12V.DC) terminal of a non-delay channel of the communicator. If the communicator is not powered from the same source as the control, also connect a jumper between terminal 20 of the control and the negative (-) "triggering by voltage" terminal of the communicator.
  - c. **If the No. 5241-12's panic alarm feature is not desired,** do not connect its VIOLET lead.
7. **Reconnect the control's battery and AC power.**

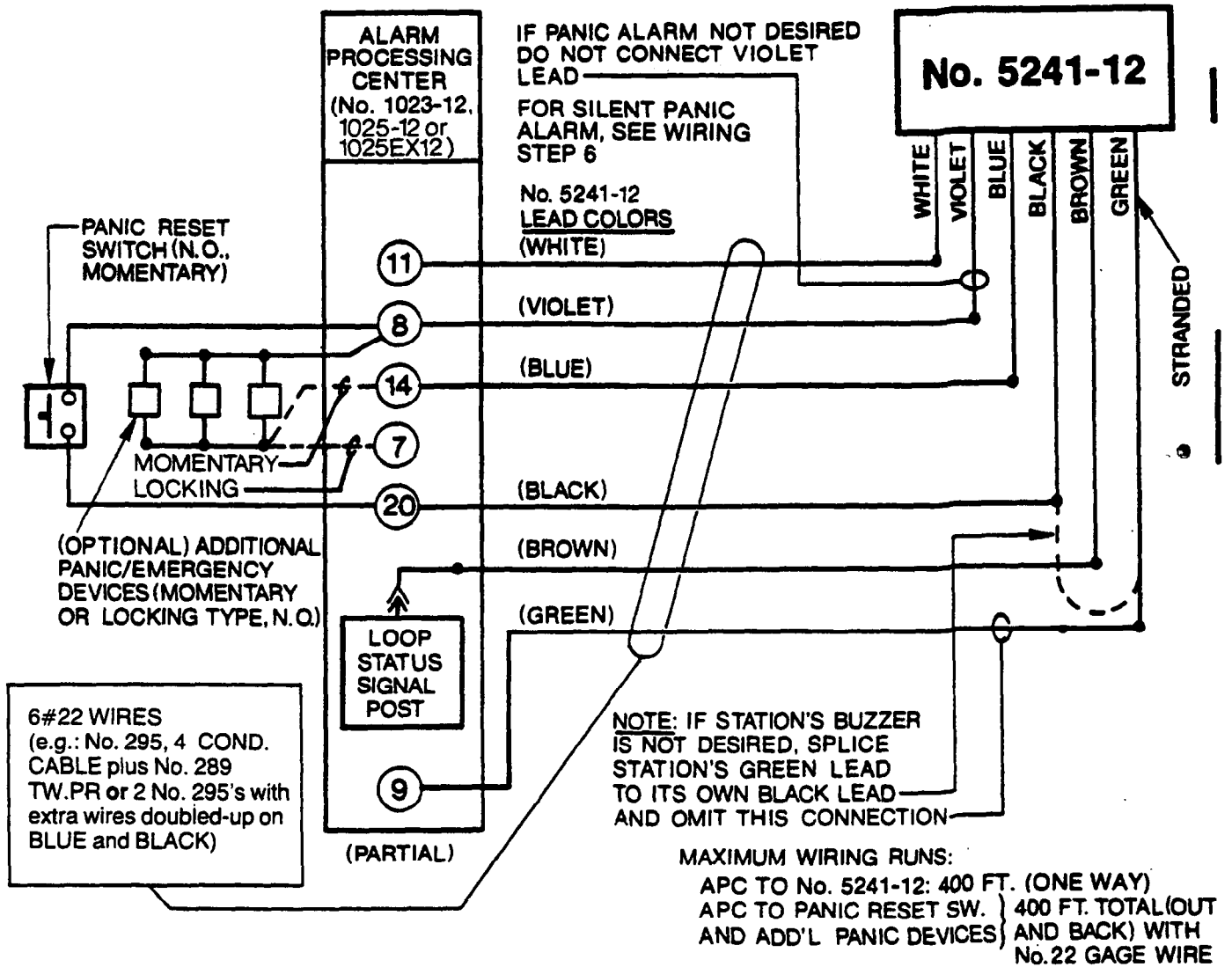

**Diagram 2: FIELD CONNECTIONS**

## TESTING AND OPERATION

The No. 5241-12 will indicate the system's status via its GREEN and RED LEDs as follows:

LED LIT	SYSTEM STATUS
NEITHER	*Disarmed, Protective Circuit(s) Disturbed or Alarm Memory Not Reset (Not Ready for Arming)
*GREEN	Disarmed, Protective Circuits Intact (Ready for Arming)
RED	Armed (Ready for Alarm or Disarming)

\*The No. 1023-12 Alarm Processing Center features automatic zone shunting and may be armed even though one or both of its basic protection zones (not the delay zone) has a fault and the remote station's GREEN LED is not lit.

**Note:** For details on other controls see the instructions that accompany the controls.

1. Arm and disarm the system at the No. 5241-12 as follows and check the response of the station's LED indicators:

**IMPORTANT**

Wait at least 5 seconds between successive attempts at arming or disarming with the No. 5241-12 or it may not be possible to successfully enter the next disarm/arm code. Exception: The 5 second wait can be eliminated by keying any digit not used in the 4 digit code and then the code.

While the 4 digit code is being entered, if more than 3 seconds are taken to enter the entire arm/disarm code (or if the code digits are not entered correctly), all prior entered information may be erased, thus requiring code entry to be started anew.

a. Make sure all protective circuits are closed and the system is ready for arming. The station's GREEN LED should be lit. If not, check the LEDs on the main panel and see the instructions that accompany the panel to interpret that information.

b. Arm the system by entering the station's programmed 4 digit code. The station's GREEN LED should go out and its RED LED should light. Wait, while the exit delay period runs its course.

If a basic protection circuit (without entry/exit delay) is subsequently disturbed, an alarm will sound immediately.

If the entry/exit delay circuit is disturbed, the No. 5241-12's buzzer will sound during the entry delay period.

c. Disarm the system by entering the station's programmed 4 digit code. The station's RED LED should go out and its GREEN LED should light (With the No. 1023-12 the GREEN LED will not light if an alarm is in the control's memory. Rearm and immediately disarm the system to clear the memory.)

Note: Each No. 5241-12's GREEN LED will go off and on as the protective circuits are opened and closed during the disarmed period.

2. Trigger a panic alarm at the No. 5241-12 as follows:

Note: This assumes that the station's VIOLET lead has not been left disconnected to eliminate this feature, as described previously.

Momentarily press the station's two buttons marked # and \* simultaneously. The panic alarm will sound (or a SILENT PANIC alarm will be sent, if so connected) and continue until the panic reset switch is operated.

If other emergency (panic) devices are being used, test each one similarly. Note: If locking type devices are used, all triggered devices must be reset before the panic reset switch is operated.

**SPECIFICATIONS:**

**Physical:** Width: 2 $\frac{7}{8}$ " (7.3 cm)  
Height: 4 $\frac{5}{8}$ " (11.7 cm)  
Depth: 1" (2.5 cm)

**Electrical:** Powered with 12V.DC from Alarm Processing Center  
Current Drain: EITHER LED ON: 12mA  
LEDs OFF: 0.2mA

One No. 5241-12 may be connected to each control unit.

**TO THE INSTALLER**

Regular maintenance and inspection (at least annually) by the installer and frequent testing by the user is vital to continuous satisfactory operation of any alarm system.

The installer should assume the responsibility of developing and offering a regular maintenance program to the user as well as acquainting the user with the proper operation and limitations of the alarm system and its component parts. Recommendations must be included for a specific program of frequent testing (at least annually) to insure the system's proper operation at all times.

Margin lines indicate principal changes since previous issue. —————→

