



INSTALLATION INSTRUCTIONS

**No. 5216
ADAPTER
WITH
KEYED SHUNTING**

for No. 215 Two Wire Digital Remote Stations with Panic (for Indoor use only)

GENERAL INFORMATION:

The No. 5216 Adapter and No. 215 Two Wire Digital Remote Station(s) with Panic Circuitry permit 4 digit coded pushbutton ON/OFF (Arm/Disarm) Control of the Nos. 1023 and 1024 Alarm Processing Centers and all combination burglar/fire controls in the Nos. 330R, 332R, 340R and 342R series. In addition, keyed shunting can be applied (or removed) at a No. 215 Remote Station, at any time, to a single zone or to shut-off space protection devices within a zone, by depressing appropriate key combinations on the No. 215 (although any manual or automatic zone shunting applied by the control takes priority).

No. 215's are for indoor use only. When used with a control without entry/exit delay (such as a No. 330R or 340R) a suitable outdoor remote station (such as No. 246, 246R or 5246) should be installed as well, to control entry/exit.

DESCRIPTION:

Only two wires are required to connect up to four No. 215 Remote Stations to the No. 5216 Adapter. A twelve pushbutton keypad on each No. 215 enables the user to arm or disarm the control, initiate a panic alarm at any time, shunt a single protection zone or directly and selectively shut off space protection devices within a zone. Status of the control's burglar alarm circuit(s) (such as: "not ready for arming", "alarm memory", "ready for arming", "keyed shunt" or "armed") is indicated by a single LED on each No. 215. An audible warning indicator is built into each No. 215 for use with those controls having entry/exit delay circuits and for other system warning sounds as the control or its accessories may provide (see instructions accompanying those units).

If desired, momentary type normally open emergency (panic) switches (e.g.: No. 219) may be connected across the remote stations' two wire circuit instead of switches separately wired to the panel (unless the remote stations' panic alarm feature is not to be connected, as described in the INSTALLATION AND WIRING Section).

A "SILENT PANIC ALARM" connection option can be used, which utilizes the No. 5216's panic circuitry to trip a digital communicator (e.g.: No. 669 or No. 670) or dialer (e.g.: No. 612). A silent alarm can then be transmitted to a remote location when the appropriate pair of buttons on a No. 215 Remote Station (or a panic switch connected across its two wire circuit) is pressed. The special connections required are incorporated in the INSTALLATION AND WIRING Section herein.

The No. 5216 Adapter's housing is designed to clip into the cabinet of the alarm control with which it is used. It contains a PC board which includes: a) Leads for alarm control connections, b) "Digit Wires" and "Code Pins" for programming the 4 digit code, c) Jumpers for cutting or positioning, as required, and d) Terminals for "Panic Reset" and No. 215 connections.

No tamper switches are needed in the No. 215 Remote Station as the system is inherently secure. A full four digit code is required to arm or disarm the system and that code

cannot be determined at any remote station. A short or even momentary low resistance between the stations' two wire run at any time will initiate a panic alarm (unless the panic feature is not to be connected, as described later).

- Notes:
- A. Only No. 215 Remote Stations (up to 4) may be used with the No. 5216 Adapter.
 - B. Circuit safeguards will prevent arming or disarming by erasing all prior information entered via the keypad if: a) an erroneous digit is entered or, b) more than approximately 3 seconds are taken to enter the code.
 - C. Other remote stations (e.g.: Nos. 214, 218R, 246, 246R, 5246) and (where required) the No. 247 Adapter may be simultaneously, but independently, connected to controls in the Nos. 330R, 332R, 340R and 342R series. As many "other" remote stations may be used as would otherwise be allowable without the No. 5216.
 - D. When a No. 5216 is used with a No. 1023 or 1024 Alarm Processing Center, a stand-alone keyswitch cannot be used for ON-OFF control of the panel.

INSTALLATION AND WIRING(See Diagram 1):

Up to four No. 215 Remote Stations may be connected to the No. 5216 in parallel, indoors on one or more two wire runs originating at the control (where the No. 5216 will be located).

The wire size to be used for the entire length of a two wire run depends upon the distance from the control to the farthest remote station on that particular run. Use the following tabulation to determine the wire size(s) needed for the proposed run(s). Twisted pair is recommended for greater immunity to unwanted induced voltages.

<u>MAXIMUM DISTANCE TO FARTHEST REMOTE STATION</u>	<u>WIRE SIZE</u>	<u>ADEMCO NO. (TWISTED PAIR)</u>
100 feet	#22	289
200	#20	283
300	#18	284
500	#16	282

If a No. 1024 Alarm Processing Center is being used, the remote station used at opening time should be located so that the ALARM MEMORY LED on the alarm processing center can be viewed at opening time before the panel is disarmed (this LED will be lit if an alarm has taken place during the armed period). (Not relevant to No. 1023, which has alarm memory by zone after disarming.)

An emergency (panic) alarm can be triggered at any No. 215 Remote Station by momentarily pressing its buttons marked # and * simultaneously.

Note: If this feature is not desired, the No. 5216's VIOLET lead may be left disconnected from the control unit during installation. See Step 8 in the following procedure.

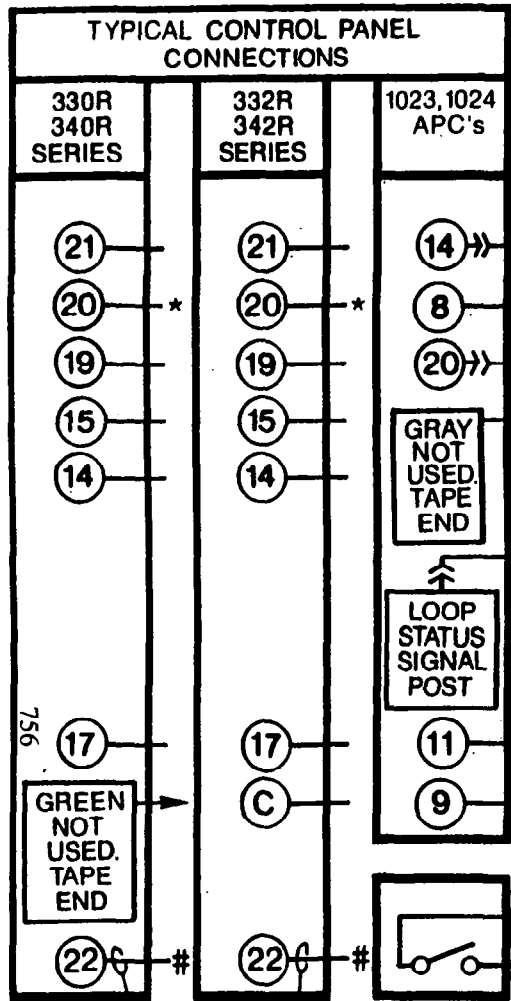

QUICK CONNECT TERMINALS PROVIDED
REMOVE WHEN CONNECTING TO SCREW TERMINALS

IF SILENT PANIC ALARM DESIRED, SEE INSTALLATION AND WIRING STEP 8 IN TEXT.

OBSERVE POLARITY!

BLUE (+)
VIOLET (+)
BLACK (-)
GRAY
BROWN

POSITION B (FOR OTHER APPLICATIONS)
POSITION A (NORMAL FOR CONTROLS SHOWN)

WHITE
GREEN
WHITE
GREEN

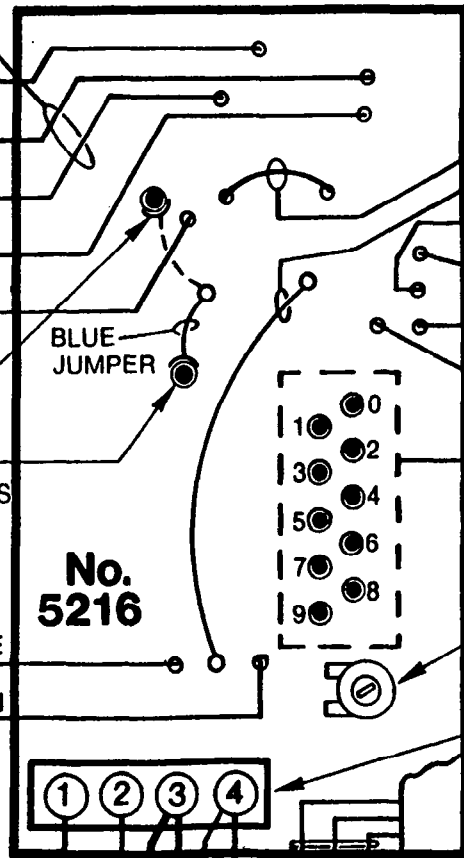

JUMPERS

VIOLET } CUT ONLY IF USED WITH CONTROL IN NOS. 330R, 340R, 332R OR 342R SERIES. (DO NOT CUT VIOLET IF SILENT PANIC ALARM IS USED.)

WHITE }

BRN (1st)
RED (2nd)
ORG (3rd)
YEL (4th)

DIGIT WIRES } FOR PROGRAMMING CODE
CODE PINS }

FACTORY ADJUSTED POTENTIOMETER. DO NOT DISTURB SETTING.

TERMINAL BLOCK

OBSERVE POLARITY AS SHOWN

TO NO. 5216 TERM. 2

PANIC RESET SWITCH, N.O. MOMENTARY (REQ'D ONLY FOR AUDIBLE PANIC ALARM WITH APC, OR SILENT PANIC ALARM WITH APC OR 330R-342R SERIES CONTROL). WIRE SIZE TO REMOTE STATIONS DEPENDS ON DISTANCE TO FARTHEST STATION (SEE TABULATION IN TEXT). EMERGENCY (PANIC) SWITCHES (N.O., MOMENTARY), IF USED, MAY BE CONNECTED IN PARALLEL ACROSS THESE LEADS.

FOR KEYED SHUNTING, SEE DIAGRAM 2

MAXIMUM TOTAL OF 4 NO. 215'S MAY BE USED WITH EACH NO. 5216.

Diagram 1: FIELD CONNECTIONS

* OMIT IF NO PANIC ALARM IS DESIRED FROM NO. 215'S.
CONNECTION REQ'D ONLY FOR AUDIBLE PANIC ALARM.

TO ADD'L REMOTE STATIONS, IF REQ'D.

ADD'L RUN(S) TO REMOTE STATIONS, IF REQ'D.

1. Locate the No. 215 Remote Station(s) and run the two wire circuit(s) between them and the control as described above. Connect the remote station RED and YELLOW leads across the "A" and "B" leads respectively, as shown in Diagram 1. Connections to the No. 5216 Adapter (to be installed within the control) will be made later. IMPORTANT: Locate the No. 215(s) where the buttons are not likely to be depressed accidentally, as this could lead to false panic alarms.

2. If desired, connect any number of momentary type N.O. emergency (panic) switches (e.g.: No. 219) across the two wire run(s) to the remote station(s).

Note: If the No. 215 Remote Stations' panic alarm feature is not to be connected (as described earlier), emergency (panic) switches may only be connected on separate wiring to the control panel, in the standard manner for audible panic alarm or directly to a digital communicator if SILENT PANIC ALARM is desired (see WIRING Step 8).

3. Remove the cover from the No. 5216 Adapter (grasp the cover at the wiring opening and pull gently) and program the PC board as follows:

a. Select a four digit "arm/disarm" code. The code may consist of any 4 different digits from 0 to 9 (e.g.: 2 1 5 8). Codes containing repeated digits (such as: 4 3 3 7 or 6 5 4 6) cannot be used.

b. Place the four "digit wires" on the appropriate "code pins". The BROWN "digit wire" should be placed on the "code pin" corresponding to the first digit in the selected code (e.g.: Pin 2, if 2 1 5 8 is the selected code). Similarly, the RED, ORANGE and YELLOW wires should be placed on the pins corresponding to the 2nd, 3rd and 4th digits respectively. All four "digit wires" must be connected for proper operation.

c. If a control in the No. 330R to 342R Series is being used, cut the 4" WHITE and 2" VIOLET jumpers on the PC board and tape the cut ends. (Caution: Do not cut the VIOLET jumper if a SILENT PANIC ALARM is to be connected.)

If a No. 1023 or 1024 Alarm Processing Center is used, the WHITE and VIOLET jumpers should never be cut.

d. DO NOT DISTURB THE FACTORY ADJUSTED POTENTIOMETER ON THE NO. 5216's PC BOARD.

e. The BLUE jumper should be on the pin at position A in Diagram 1 when the No. 5216 is used with any of the controls shown. Position B is for other applications (described elsewhere).

4. Disconnect the control's battery and AC power.

5. Connect the remote station wiring to terminals 3 and 4 of the No. 5216, observing the "polarity" shown in the diagram. Allow enough slack to reach the final position the No. 5216 will occupy in the control.

Note: The cover of the No. 5216 is provided with a mounting lip which can be slipped over the edge of the control cabinet, (during Step 7) without interfering with the closing of the cabinet's cover.

IF THE NO. 215's PANIC ALARM FEATURE IS NOT TO BE CONNECTED (AS DESCRIBED EARLIER IN THIS SECTION) SKIP THE FOLLOWING STEP 6, AND PROCEED TO STEP 7.

6. Connect Panic Reset wiring between the No. 5216 and the control (or separate reset switch) as indicated in Diagram 1.

Note: If a No. 1023 or 1024 Alarm Processing Center is to be used with audible panic alarm (or if SILENT PANIC ALARM is to be used with an APC or a No. 330R-342R Series control) a N.O. momentary contact switch for Panic Reset must be provided. The knockout provided in the cover of the No. 1023 or 1024 may be used for mounting the switch, or it may be located remotely [suggested keyswitches: No. 2174-70 (flat key), No. 4073-70 (round key), No. 5073-70 (higher security, pick resistant)...or simply a No. 8064 Pushbutton may be used].

7. Replace the cover of the No. 5216 (dress all wires through the opening at one end of the cover) and install the unit inside the control cabinet by slipping its mounting lip over the edge of the cabinet.
8. Connect the No. 5216's remaining leads (for the RED, YELLOW and ORANGE keyed shunting leads see Step 9) to the control as indicated in Diagram 1.

CAUTIONS: The BLUE(+) and BLACK(-) leads supply power to the No. 5216. Polarity must be observed or a burnout will result.

The VIOLET lead must not contact ground or any point, other than called for in the diagram, or a burnout may result. If it is not used (see next paragraph), tape its end.

Notes: If the No. 215 Remote Stations' panic alarm feature is not to be connected (as described earlier in this section) do not connect the No. 5216's VIOLET wire, but tape its end.

If SILENT PANIC ALARM is desired, do not connect the VIOLET (+) lead to the control. Instead, connect the VIOLET (+) lead and the control terminal to which the BLACK (-) lead is connected, to the voltage triggering points of a digital communicator (a non-delay channel is recommended) or dialer. Observe polarity! (6V. DC appears across these leads when activated.)

If a control with entry/exit delay is used, audible warning is recommended for security and user convenience, but...

If audible warning is undesirable at the No. 215 Remote Station(s), do not connect the No. 5216's GREEN wire.

If any one No. 215 is to be silenced while others are not, connect the No. 5216's GREEN wire as shown in the diagram, but cut the thin ORANGE lead to the sounder in the No. 215 that is to be silenced.

9. If the No. 5216's keyed shunting feature is to be used, connect the unit's RED, YELLOW and ORANGE keyed shunting leads to a single zone in the control as indicated in Diagram 2, or to space protection devices as indicated in Diagram 3.

Notes: Do not use the No. 5216's keyed shunting feature in conjunction with a "fast response" zone (to avoid possible detection of the brief opening of the keyed shunting relay contacts as they operate).

SAME VALUE AS END-OF-LINE
RESISTOR USED IN
PROTECTIVE LOOP

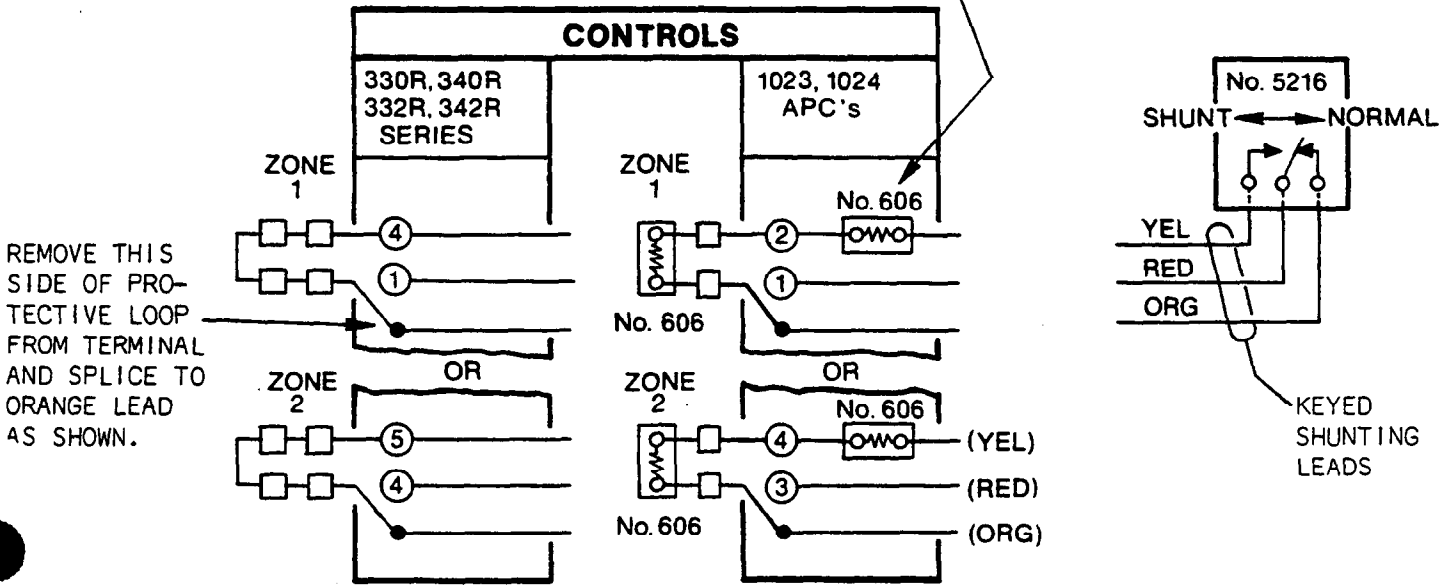

NOTE: DO NOT USE No. 5216 IN CONJUNCTION
WITH A "FAST" RESPONSE ZONE.

Diagram 2: TYPICAL CONNECTIONS, KEYED SHUNTING OF SINGLE ZONE

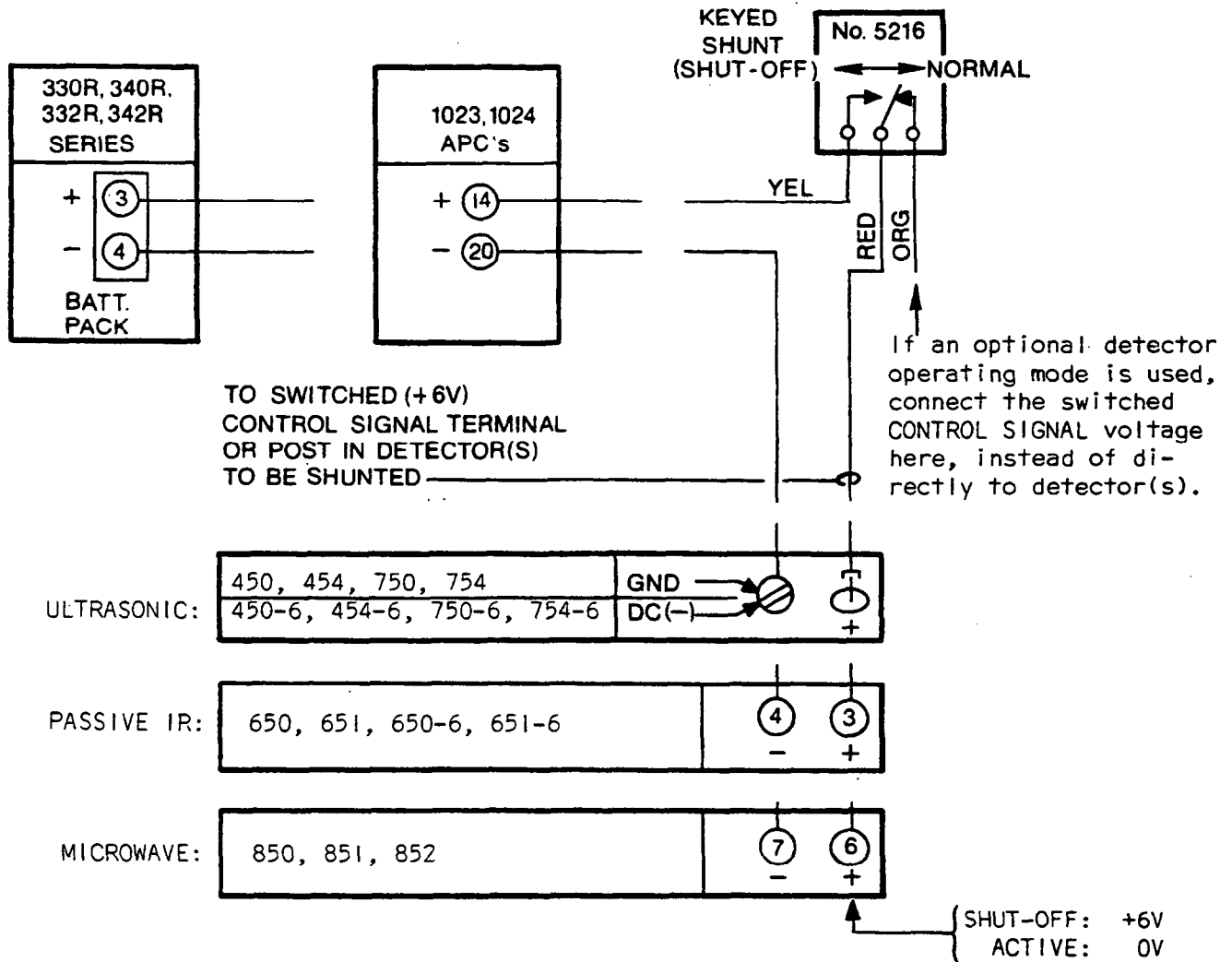

Diagram 3: TYPICAL CONNECTIONS, KEYED SHUNTING (SHUTOFF) OF SPACE PROTECTION DEVICES

If an end-of-line resistor is normally used in a zone selected for keyed shunting, a similar resistor must be connected in series with the No. 5216's YELLOW lead as shown.

A keyed shunt connected to a space protection device will lock the detector in its "standby" state and keep its alarm contacts from operating as long as the shunt is in effect. With ultrasonic detectors (such as those in the Nos. 450, 454, 750 and 754 series) which have one of their transmitter day shut-off options selected, the power to the transmitters will be off while a keyed shunt is in effect.

10. Reconnect the control's battery and A.C. power.

TESTING AND OPERATION:

Arming and disarming of the system and (if used) keyed shunting may be carried out at any remote station.

The following tabulation shows how each remote stations' LED will indicate the system's status when used with a No. 1023 or 1024 APC or a control in the 330R, 332R, 340R or 342R series.

LED ON No. 215	SYSTEM STATUS: No. 1023 or 1024 APC or No. 330R, 332R, 340R, or 342R SERIES CONTROL
OFF	DISARMED, PROTECTIVE CIRCUIT(S) OPEN or (with No. 1023) ALARM STORED IN PANEL'S MEMORY (see control's instructions)
LED's on Alarm Processing Center will be lit for specific zone(s) not ready for arming (or flashing for memory in a No. 1023 alarmed zone which has restored. If No. 1023's LED is flashing, system may be armed directly without any loss of protection. To clear panel's memory and restore flashing condition to remote station LEDs, arm and immediately disarm the system.)	
FLASHING (NO BUZZER) OFF more than ON	DISARMED, PROTECTIVE CIRCUIT(S) CLOSED (Ready for Arming)
<p><u>The Nos. 1023 and 1024 Alarm Processing Centers feature automatic loop shunting and may be armed even though one or both of their basic protection zones (not the delay zone) has a fault, and the remote station LED is not flashing (automatic loop shunting may be optionally disabled in the No. 1024).</u></p> <p><u>If the fire circuit of a No. 245 Adapter is being used concurrently with a No. 5216 and 215(s) (for arming/disarming) connected to a No. 1023 or 1024 APC, the buzzer in each No. 215 will sound intermittently in the event of trouble in the fire loop.</u></p>	
FLASHING (NO BUZZER) ON more than OFF	ARMED (Keyed Shunting by No. 5216 in Effect)
ON STEADILY	ARMED (Ready for Alarm or Disarming)
<p><u>If the fire circuit of a No. 245 is being used concurrently with a No. 5216 and 215(s) (for arming/disarming) connected to a No. 1023 or 1024 APC, the buzzer in each No. 215 will sound steadily in the event of trouble in the fire loop.</u></p>	

For details of operation with other controls, see the instructions that accompany the particular controls.

1. Arm and disarm the system at each remote station and check the response of each station's LED indicator (see Note B on page 2):

a. Make sure all protective circuits are closed and system is ready for arming (remote station LED should be flashing, more OFF than ON).

b. Arm the system by entering the 4 digit code at the remote station (the remote station LED should light steadily).

If a basic protection circuit (without entry/exit delay) is disturbed, an alarm will sound immediately.

If an entry/exit delay circuit is disturbed, the remote station's audible indicator will sound during the "entry delay" period. If the system is not disarmed before the entry delay period expires, an alarm will result.

For buzzer warnings that occur during other than normal arming conditions, see the instructions that accompany the control.

c. Disarm the system by entering the entire 4 digit code at the remote station. (the station's LED should go off or start flashing, more OFF than ON).

2. If the No. 5216's keyed shunting feature has been connected, its action should be tested in each of the following ways:

a. Apply a keyed shunt and arm the system: At a No. 215 Remote Station, key any digit (other than the first digit of the arm/disarm code) followed by the full 4 digit arm/disarm code. Each No. 215's LED will flash (more ON than OFF) to indicate arming with keyed shunt in effect.

b. Remove the keyed shunt without changing the armed status of the system: Key only the first 3 digits of the arm/disarm code. Each No. 215's LED will then light steadily to indicate that the system is armed and no keyed shunt is in effect.

c. Apply a keyed shunt while the system is still armed: Key any digit (other than the first digit of the arm/disarm code) followed by only the first 3 digits of the arm/disarm code. Each No. 215's LED will then flash (more ON than OFF) to indicate that the system is armed with a keyed shunt in effect.

d. Disarm the system (keyed shunt will be automatically removed): Key the full 4 digit arm/disarm code.

Note: It is possible to initiate a keyed shunt while the system is disarmed by keying any digit (other than the first digit of the arm/disarm code) followed by only the first 3 digits of the arm/disarm code. When this happens (if all zones are otherwise intact) each No. 215's LED will be flashing, more OFF than ON, but at a somewhat slower rate than normally. Clear the shunt by keying only the first 3 digits of the arm/disarm code or clear the shunt and arm the system by keying the full 4 digit arm/disarm code.

3. Trigger panic alarms as follows:

Note: This assumes that the No. 5216's VIOLET wire has not been left disconnected, to eliminate this feature, as described previously.

- a. On a No. 215 Remote Station, momentarily press the buttons marked # and * simultaneously. The panic alarm will sound (or a silent alarm will be sent) and continue until the reset switch (included in the Nos. 330R, 332R, 340R and 342R Controls...separately provided as described herein for the Nos. 1023 and 1024 Alarm Processing Centers or for SILENT PANIC ALARM) is operated. Repeat for each additional No. 215 Remote Station.
- b. If additional panic switches have been connected across the remote station wiring, test them as well.

SEE KEYING SUMMARY ON NEXT PAGE

SPECIFICATIONS:

	<u>No. 5216</u>	<u>No. 215</u>
<u>Physical:</u>	Width: 3 3/4" (9.5 cm)	2 7/8" (7.3 cm)
	Height: 6 7/8" (17.5 cm)	4 5/8" (11.7 cm)
	Depth: 1 1/4" (3.2 cm)	1" (2.5 cm)

Electrical: No. 5216 is powered with 6V. DC from control instrument (see GENERAL INFORMATION for controls that may be used).

Up to 4 No. 215's may be connected to one No. 5216.

Current Drain: 32ma for No. 5216 plus 9.1 ma per No. 215 (LED lit steadily)

TO THE INSTALLER

Regular maintenance by the installer and frequent testing by the user is vital to continuous satisfactory operation of any alarm system.

The installer should assume the responsibility of developing and offering a regular maintenance program to the user as well as acquainting the user with the proper operation and limitations of the alarm system and its component parts. Recommendations must be included for a specific program of frequent testing to insure the system's proper operation at all times.

KEYING SUMMARY: No. 215(s) USED WITH No. 5216

DESIRED ACTION	No. 215's LED <u>BEFORE</u> KEYING	KEYING ^(A)	No. 215's LED <u>AFTER</u> KEYING
ARM, NO SHUNT ^(B)	FLASHING: OFF more than ON	N1-N2-N3-N4	ON STEADILY
ARM & APPLY SHUNT	FLASHING: OFF more than ON	NX-N1-N2-N3-N4	FLASHING: ON more than OFF
APPLY SHUNT & REMAIN ARMED	ON STEADILY	NX-N1-N2-N3	FLASHING: ON more than OFF
REMOVE SHUNT & REMAIN ARMED	FLASHING: ON more than OFF	N1-N2-N3	ON STEADILY
DISARM (Removes shunt, if any)	ON STEADILY or FLASHING: ON more than OFF	N1-N2-N3-N4	FLASHING: OFF more than ON (or OFF if zone not intact)
PANIC ALARM	At any time	* and # SIMULTANEOUSLY	No change

658

(A): N1-N2-N3-N4 = 4 digit arm/disarm code.
NX = any digit other than N1 (first digit of arm/disarm code).

(B): "SHUNT" in this summary refers to a keyed shunt applied, via the Nos. 215/5216, to shunt a single zone on the control or to turn off individual space protection devices within a zone.