

ADEMCO

INSTALLATION INSTRUCTIONS

**No. 5213-12
ADAPTER
WITH
KEYED SHUNTING**

for No. 5212 Three LED Digital Remote Station(s) with Panic (for Indoor use only)

GENERAL INFORMATION:

The No. 5213-12 Adapter and No. 5212 Three LED Digital Remote Station with Panic Circuitry permit 4 digit Coded pushbutton ON/OFF (Arm/Disarm) Control of the Nos. 1021-12, 1023-12, 1025-12 and 1025EX12 Alarm Processing Centers. In addition, keyed shunting can be applied at a No. 5212 Remote Station, at any time, to a single zone or to shut-off space protection devices, by depressing appropriate key combinations on the No. 5212.

The adapter has the ability to add FAIL SAFE arming capability to controls with which it is used that do not already have this capability. FAIL SAFE arming means that the control will **not** be armed unless the GREEN LED at the No. 5212 Remote Station(s) is ON (the adapter will not generate the arming signal). This capability can be optionally suppressed so that the adapter will **always** produce an arming signal to the control (independent of loop status) so that the control's normal response to arming with a faulted zone (i.e.: automatic zone shunting or alarm) can be obtained.

No. 5212s are for indoor use only.

DESCRIPTION:

Only four wires are required to connect up to four No. 5212 Remote Stations to the No. 5213-12 Adapter. A twelve pushbutton keypad on each No. 5212 enables the user to arm or disarm the control, initiate a panic alarm at any time, shunt a single protection zone or directly and selectively shut off space protection devices. Status of the control's burglar alarm circuit(s) (such as: "not ready for arming", "alarm memory", "ready for arming", "keyed shunt" or "armed") is indicated by three LEDs on each No. 5212. An audible warning indicator is built into each No. 5212 for use with those controls having entry/exit delay circuits and for other system warnings as the control or its accessories may provide (see instructions accompanying those units).

If desired, momentary type normally open emergency (panic) switches (e.g.: No. 219) may be connected across two conductors (RED and YELLOW) of the remote stations' four wire circuit instead of switches separately wired to the panel (unless the remote stations' panic alarm feature is not to be connected, as described in the INSTALLATION AND WIRING Section).

A "SILENT PANIC ALARM" connection option can be used, which utilizes the No. 5213-12's panic circuitry to trip a digital communicator (e.g.: No. 669, 678 or 693) or dialer (e.g.: No. 612). A silent alarm can then be transmitted to a remote location when the appropriate pair of buttons on a No. 5212 Remote Station (or a panic switch connected across its RED and YELLOW wires) is pressed. The special connections required are incorporated in the INSTALLATION AND WIRING Section herein.

The No. 5213-12 Adapter's housing is designed to clip into the cabinet of the alarm control with which it is used. It contains a PC board which includes: a) Leads for alarm control and No. 5212 connections, b) "Digit Wires" and "Code Pins" for programming the 4 digit code, c) Jumpers for cutting or positioning, as required, and d) Terminals for "Panic Reset" and No. 5212 connections.

No tamper switches are needed in the No. 5212 Remote Station as the system is inherently secure. A full four digit code is required to arm or disarm the system and that code cannot be determined at any remote station.

- Notes:**
- A. Only No. 5212 Remote Stations (up to 4) may be used with the No. 5213-12 Adapter.
 - B. Circuit safeguards will prevent arming or disarming by erasing all prior information entered via the keypad if: a) an erroneous digit is entered or, b) more than approximately 3 seconds are taken to enter the code.
 - C. When a No. 5213-12 is used with a No. 1023-12, 1025-12 or 1025EX12 Alarm Processing Center, a **stand-alone keyswitch cannot be used for ON-OFF control of the panel, nor can a keyswitch arming adapter (e.g.: No. 244-12 or 245-12) with remote keyswitches be used.**
 - D. The No. 5213-12 is not suitable for use with the Nos. 4080-12 and 4080EU LogiCenters.

INSTALLATION AND WIRING (See Diagram 1):

Up to four No. 5212 Remote Stations may be connected to the No. 5213-12 in parallel, indoors on one or more four wire runs originating at the control (where the No. 5213-12 will be located).

The wire size to be used for the entire length of a four wire run depends upon the distance from the control to the farthest remote station on that particular run. Use the following tabulation to determine the wire size(s) needed for the proposed run(s). Twisted pair is recommended for greater immunity to unwanted induced voltages.

| MAXIMUM DISTANCE TO FARTHEST REMOTE STATION | WIRE SIZE | ADEMCO NO. (TWISTED PAIR) |
|---|-----------|---------------------------|
| 100 feet | #22 | 2 No. 289* |
| 200 | #20 | 2 No. 283 |
| 300 | #18 | 2 No. 284 |
| 500 | #16 | 2 No. 282 |

*Alternatively, No. 295 (4 conductor) cable can be used.

If a No. 1025-12 or 1025EX12 Alarm Processing Center is being used, the remote station used at opening time should be located so that the ALARM MEMORY LED on the alarm processing center can be viewed at opening time before the panel is disarmed (this LED will be lit if an alarm has taken place during the armed period). (Not relevant to Nos. 1021-12 and 1023-12, which have alarm memory by zone after disarming.)

An emergency (panic) alarm can be triggered at any No. 5212 Remote Station by momentarily pressing its buttons marked # and * simultaneously.

Note: If use of this feature is not desired, the No. 5213-12's VIOLET lead may be left disconnected from the control unit during installation. See Step 8 in the following procedure.

1. a. Cut the BLUE jumper in each No. 5212 Remote Station (for 12V operation).
- b. Locate the No. 5212 Remote Station(s) and run the four wire circuit(s) between them and the control as described earlier. Connect the remote station RED, YELLOW, ORANGE and BLACK leads as shown in Diagram 1. Connections to the No. 5213-12 Adapter (to be installed within the control) will be made later. **IMPORTANT:** Locate the No. 5212(s) where the buttons are not likely to be depressed accidentally, as this could lead to false panic alarms.
2. If desired, connect any number of momentary type N.O. emergency (panic) switches (e.g.: No. 219) across the RED and YELLOW wire run(s) to the remote station(s).

Note: If the No. 5212 Remote Stations' panic alarm feature is not to be used (as described earlier), emergency (panic) switches may **only** be connected on separate wiring to the control panel, in the standard manner for audible panic alarm or directly to a digital communicator if SILENT PANIC ALARM is desired (see WIRING Step 8).

3. Remove the cover from the No. 5213-12 Adapter (grasp the cover at the wiring opening and pull gently) and program the PC board as follows:
 - a. Select a four digit "arm/disarm" code. The code may consist of any 4 different digits from 0 to 9 (e.g.: 2 1 5 8). Codes containing repeated digits (such as: 4 3 3 7 or 6 5 4 6) cannot be used.
 - b. Place the four "digit wires" on the appropriate "code pins". The BROWN "digit wire" should be placed on the "code pin" corresponding to the first digit in the selected code (e.g.: Pin 2, if 2 1 5 8 is the selected code). Similarly, the RED, ORANGE and YELLOW wires should be placed on the pins corresponding to the 2nd, 3rd and 4th digits respectively. All four "digit wires" must be connected for proper operation.
 - c. If a No. 1021-12 Alarm Processing Center is being used, cut the 4" WHITE jumper on the PC board and tape the cut ends.
 - d. DO NOT DISTURB THE FACTORY ADJUSTED POTENTIOMETER ON THE No. 5213-12's PC BOARD.
 - e. The BLUE jumper should be on the pin at position A in Diagram 1 when the No. 5213-12 is used with any of the controls shown.
 - f. The YELLOW jumper should be left on its pin (as shown in Diagram 1) when the FAIL SAFE arming function of the No. 5213-12 Adapter is used and should be removed and taped when the control's normal response to arming with a faulted zone (i.e.: automatic zone shunting or alarm) is desired.

With a No. 1023-12 APC, usage of the FAIL SAFE arming function creates a special situation. The memory of alarm feature of this APC keeps the GREEN LED OFF in the disarmed state and arming of the control is required to clear that memory condition (not possible if FAIL SAFE arming is desired, where no arming signal can be produced unless the GREEN LED is ON). If, therefore, it is desired to use FAIL SAFE arming with a No. 1023-12 APC, it is necessary to add a normally open momentary switch (e.g.: No. 116), connected between terminals 11 and 20 of the control, as a memory reset switch, installed either locally at the control or remotely.

4. Disconnect the control's battery and AC power.
5. Connect the remote station wiring to the No. 5213-12, observing the "polarity" shown in the diagram. Allow enough slack to reach the final position the No. 5213-12 will occupy in the control.

Note: The cover of the No. 5213-12 is provided with a mounting lip which can be slipped over the edge of the control cabinet, (during Step 7) without interfering with the closing of the cabinet's cover.

IF THE NO. 5212's PANIC ALARM FEATURE IS NOT TO BE USED (AS DESCRIBED EARLIER IN THIS SECTION), SKIP THE FOLLOWING STEP 6, AND PROCEED TO STEP 7.

6. Connect Panic Reset wiring between the No. 5213-12 and the control as indicated in Diagram 1. A N.O. momentary contact switch for Panic Reset must be provided. The knockout provided in the cover of the control may be used for mounting the switch, or it may be located remotely [suggested keyswitches: No. 2174-70 (flat key), No. 4073-70 (round key), No. 5073-70 (higher security, pick resistant)...or simply a No. 8064 Pushbutton may be used].

- 7. Replace the cover of the No. 5213-12** (dress all wires through the opening at one end of the cover) and install the unit inside the control cabinet by slipping its mounting lip over the edge of the cabinet.
- 8. Connect the No. 5213-12's remaining leads** (for the RED, YELLOW and ORANGE keypad shunting leads see Step 9) to the control as indicated in Diagram 1.

CAUTIONS: The Blue (+) and BLACK (-) leads supply power to the No. 5213-12. Polarity must be observed or a burnout will result.

The VIOLET lead must not contact ground or any point, other than called for in the diagram, or a burnout may result. If it is not used (see next paragraph), tape its end.

Notes: If the No. 5212 Remote Stations' panic alarm feature is not to be used (as described earlier in this section) do not connect the No. 5213-12's VIOLET wire, but tape its end.

If SILENT PANIC ALARM is desired, do not connect the VIOLET (+) lead to the control. Instead, connect the VIOLET (+) lead and the control terminal to which the BLACK (-) lead is connected, to the voltage triggering points of a digital communicator (a non-delay channel is recommended) or dialer. Observe polarity! (12V. DC appears across these leads when activated.)

In a control with entry/exit delay, audible warning is recommended for security and user convenience, but...

If audible warning is undesirable at the No. 5212 Remote Station(s), do not connect the No. 5213-12's GREEN wire.

If any one No. 5212 is to be silenced while others are not, connect the No. 5213-12's GREEN wire as shown in the diagram, but cut the thin ORANGE lead to the sounder in the No. 5212 that is to be silenced.

- 9. If the No. 5213-12's keyed shunting feature is to be used, connect the unit's RED, YELLOW and ORANGE keyed shunting leads** to a single zone in the control as indicated in Diagram 2, or to space protection devices as indicated in Diagram 3.

Notes: Do not use the No. 5213-12's keyed shunting feature in conjunction with a "fast response" zone (to avoid possible detection of the brief opening of the keyed shunting relay contacts as they operate).

If an end-of-line resistor is normally used in a zone selected for keyed shunting, a similar resistor must be connected in series with the No. 5213-12's YELLOW lead as shown.

A keyed shunt connected to any space protection device shown in Diagram 3 will lock the detector in its "standby" state and keep its alarm contacts from operating as long as the shunt is in effect. With ultrasonic detectors (such as those in the Nos. 450, 454, 760 and 764 series) which have one of their transmitter day shut-off options selected, the power to the transmitters will be off while a keyed shunt is in effect.

- 10. Reconnect the control's battery and A.C. power.**

TESTING AND OPERATION:

Arming and disarming of the system and (if used) keyed shunting may be carried out at any remote station.

The following tabulation shows how each remote station's LEDs will indicate the system's status when used with a No. 1021-12, 1023-12, 1025-12 or 1025EX12 Alarm Processing Center.

| LEDS on No. 5212 | | SYSTEM STATUS: |
|--|---------------|--|
| | YELLOW OFF | DISARMED, PROTECTIVE CIRCUIT (s) FAULTED or (with No. 1021-12 or 1023-12 APC) ALARM STORED IN PANEL'S MEMORY (see control's instructions). |
| GREEN OFF | RED OFF | |
| <p>With an Alarm Processing Center, LED(s) on APC will be lit for specific zone(s) not ready for arming or lit to indicate memory in a No. 1021-12 or 1023-12 alarmed zone which has restored (flashing on a No. 1023-12). The No. 1021-12 may have a panic alarm stored which is not indicated on the panel but is keeping the No. 5212's GREEN LED OFF.</p> <p>If a No. 1023-12's LED is flashing, the system may be armed directly without any loss of protection, if the No. 5213-12's FAIL SAFE arming feature is not in use. If FAIL SAFE arming is being used, the No. 1023-12's memory must first be cleared by operating the MEMORY RESET switch (see INSTALLATION AND WIRING Step 3f) to restore the ON condition to the No. 5212's GREEN LED.</p> <p>To clear the No. 1021-12's memory (and turn ON the No. 5212's GREEN LED) press the RESET switch on the front of the No. 1021-12.</p> <p>The No. 1023-12 Alarm Processing Center features automatic loop shunting and (if the No. 5213-12's FAIL SAFE arming capability is not used) may be armed even though one or both of its basic protection zones (not the delay zone) has a fault, and the No. 5212's GREEN LED is not ON.</p> | | |
| | YELLOW OFF | DISARMED, PROTECTIVE CIRCUIT(s) CLOSED (Ready for arming). |
| GREEN ON | RED OFF | |
| | YELLOW ON | DISARMED, PROTECTIVE CIRCUIT(s) CLOSED (Ready for arming), KEYED SHUNTING BY No. 5213-12 IN EFFECT. |
| GREEN ON | RED OFF | |
| <p>If the fire circuit of a No. 263-12 Fire Module is being used concurrently with a No. 5213-12 and 5212(s) connected to a No. 1023-12, 1025-12 or 1025EX12 APC, the buzzer in each No. 5212 will sound intermittently in the event of trouble in the fire loop while the system is disarmed (not applicable to No. 1021-12 APC).</p> | | |
| | YELLOW OFF | ARMED (Ready for Alarm or Disarming) |
| GREEN OFF | RED ON | |
| | YELLOW ON | ARMED (Ready for Alarm or Disarming), KEYED SHUNTING BY No. 5213-12 IN EFFECT. |
| GREEN OFF | RED ON | |
| <p>If the fire circuit of a No. 263-12 is being used concurrently with a No. 5213-12 and 5212(s) connected to a No. 1023-12, 1025-12 or 1025EX12 APC, the buzzer in each No. 5212 will sound steadily in the event of trouble in the fire loop while the system is armed (not applicable to the No. 1021-12 APC).</p> | | |

1. Arm and disarm the system at each remote station and check the response of each station's LED indicators (see Note B on page 1):
 - a. Make sure all protective circuits are closed and system is ready for arming (remote station GREEN LED should be ON).

- b. Arm the system by entering the 4 digit code at the remote station (the remote station RED LED should be ON).
If a basic protection circuit (without entry/exit delay) is disturbed, an alarm will sound immediately.
If an entry/exit delay circuit is disturbed, the remote station's audible indicator will sound during the "entry delay" period. If the system is not disarmed before the entry delay period expires, an alarm will result.
For buzzer warnings that occur during other than normal arming conditions, see the instructions that accompany the control.
- c. Disarm the system by entering the entire 4 digit code at the remote station. The station's RED LED should go OFF and the GREEN LED should turn ON (if no memory of alarm remains).

2. If the No. 5213-12's keyed shunting feature has been connected, its action should be tested in each of the following ways:

- a. Apply a keyed shunt and arm the system: At a No. 5212 Remote Station, key any digit (other than the the first digit of the arm/disarm code) followed by the full 4 digit arm/disarm code. Each No. 5212's RED and YELLOW LEDs will turn ON to indicate arming with keyed shunt in effect.
- b. Disarm the system as described in Step 1c. The keyed shunt will be automatically removed. The RED and YELLOW LEDs should go OFF and the GREEN LED should go ON.
- c. Arm the system as described in Step 1b. The GREEN LED should go OFF and the RED LED should go ON.
- d. Apply a keyed shunt while the system is still armed: Key any digit (other than the first digit of the arm/disarm code) followed by only the first 3 digits of the arm/disarm code. Each No. 5212's RED and YELLOW LEDs will then be ON to indicate that the system is armed with a keyed shunt in effect.
- e. Disarm the system (keyed shunt will be automatically removed): Key the full 4 digit arm/disarm code. As in Step 2b, the RED and YELLOW LEDs will go OFF and the GREEN LED will turn ON.

Note: It is possible to initiate a keyed shunt while the system is disarmed by keying any digit (other than the first digit of the arm/disarm code) followed by only the first 3 digits of the arm/disarm code. When this happens, each No. 5212's YELLOW LED will be ON. Clear the shunt by arming and disarming the system (key the full 4 digit arm/disarm code twice).

3. Trigger panic alarms as follows:

Note: This assumes that the No. 5213-12's VIOLET wire has not been left disconnected, to eliminate this feature, as described previously.

- a. At a No. 5212 Remote Station, momentarily press the buttons marked # and * simultaneously. The panic alarm will sound (or a silent alarm will be sent) and continue until the PANIC RESET switch (see Diagram 1) is operated. Repeat for each additional No. 5212 Remote Station.
- b. If additional panic switches have been connected across the remote station wiring, test them as well.

SEE KEYING SUMMARY.

SPECIFICATIONS:

| | No. 5213-12 | No. 5212 |
|--------------------|--|---|
| Physical: | Width: 3 ³ / ₄ " (9.5 cm) | 2 ⁷ / ₈ " (7.3 cm) |
| | Height: 6 ⁷ / ₈ " (17.5 cm) | 4 ⁵ / ₈ " (11.7 cm) |
| | Depth: 1 ¹ / ₄ " (3.2 cm) | 1" (2.5 cm) |
| Electrical: | No. 5213-12 is powered with 12V. DC from control instrument (see GENERAL INFORMATION for controls that may be used). | |
| | Up to 4 No. 5212s may be connected to one No. 5213-12. | |
| | Current Drain: 16mA for No. 5213-12 plus 15mA per No. 5212 (two LEDs lit). | |

TO THE INSTALLER

Regular maintenance and inspection (at least annually) by the installer and frequent testing by the user are vital to continuous satisfactory operation of any alarm system.

The installer should assume the responsibility of developing and offering a regular maintenance program to the user as well as acquainting the user with the proper operation and limitations of the alarm system and its component parts. Recommendations must be included for a specific program of frequent testing (at least annually) to insure the system's proper operation at all times.

KEYING SUMMARY: No. 5212(s) USED WITH No. 5213-12

| DESIRED ACTION (ADAPTER'S FAIL SAFE ARMING ASSUMED USED) | | No. 5212's LEDs BEFORE KEYING | | | KEYING Ⓐ | No. 5212's LEDs AFTER KEYING | | |
|--|---|----------------------------------|-----------|-----------|---|---------------------------------|------------------------------|------------------|
| | | GREEN | RED | YELLOW | | GREEN | RED | YELLOW |
| ARM, NO SHUNT ⓑ | | ON | OFF | OFF | N1-N2-N3-N4 | OFF | ON | OFF |
| ARM AND REMOVE PREVIOUSLY APPLIED SHUNT | | ON | OFF | ON | ARM: N1-N2-N3-N4 DISARM: N1-N2-N3-N4 ARM: N1-N2-N3-N4 | OFF ON OFF | ON OFF ON | ON OFF OFF |
| ARM AND MAINTAIN PREVIOUSLY APPLIED SHUNT | | ON | OFF | ON | N1-N2-N3-N4 or: NX-N1-N2-N3-N4 | OFF | ON | ON |
| ARM AND APPLY SHUNT | System Intact | ON | OFF | OFF | NX-N1-N2-N3-N4 | OFF | ON | ON |
| | Faulted zone, to be shunted | OFF | OFF | OFF | NX-N1-N2-N3-N4 | OFF | ON | ON |
| | Faulted zone, but shunt to be applied elsewhere | OFF | OFF | OFF | NX-N1-N2-N3-N4 (if attempted) | OFF | OFF (system will not arm) | ON |
| REMAIN ARMED AND APPLY SHUNT | | OFF | ON | OFF | NX-N1-N2-N3 | OFF | ON | ON |
| REMAIN ARMED AND REMOVE SHUNT | | OFF | ON | ON | DISARM: N1-N2-N3-N4 then REARM: N1-N2-N3-N4 | ON OFF | OFF ON | OFF OFF |
| DISARM, NO SHUNT PRESENT | | OFF | ON | OFF | N1-N2-N3-N4 | ON ⓐ (if system intact) | OFF | OFF |
| DISARM, SHUNT PRESENT | | OFF | ON | ON | N1-N2-N3-N4 | ON ⓐ (if system intact) | OFF | OFF |
| REMAIN DISARMED AND APPLY SHUNT | System Intact | ON | OFF | OFF | NX-N1-N2-N3 | ON | OFF | ON |
| | Faulted zone, to be shunted | OFF | OFF | OFF | NX-N1-N2-N3 | ON | OFF | ON |
| | Faulted zone, but shunt to be applied elsewhere | OFF | OFF | OFF | NX-N1-N2-N3 | OFF | OFF | ON |
| REMAIN DISARMED AND REMOVE SHUNT | | ON | OFF | ON | ARM: N1-N2-N3-N4 then DISARM: N1-N2-N3-N4 | OFF ON | ON OFF | ON OFF |
| PANIC ALARM | Disarmed, System Intact | ON | OFF | OFF or ON | * AND # SIMULTANEOUSLY | ON ⓐ | OFF | OFF or ON |
| | Disarmed, Zone(s) Faulted Armed | OFF | OFF or ON | OFF or ON | * AND # SIMULTANEOUSLY | OFF | OFF or ON (no change) | OFF or ON |

644

Ⓐ : N1-N2-N3-N4 = 4 digit arm/disarm code.
NX = any digit other than N1 (first digit of arm/disarm code).

ⓑ : "SHUNT" in this summary refers to a keyed shunt applied, via the Nos. 5212/5213-12 to shunt a single zone on the control or to turn off individual space protection code(s).

ⓐ : With No. 1021-12 and 1023-12 APCs, GREEN will be OFF if memory of alarm is present.

ⓐ : With No. 1021-12 APC, GREEN will be OFF.

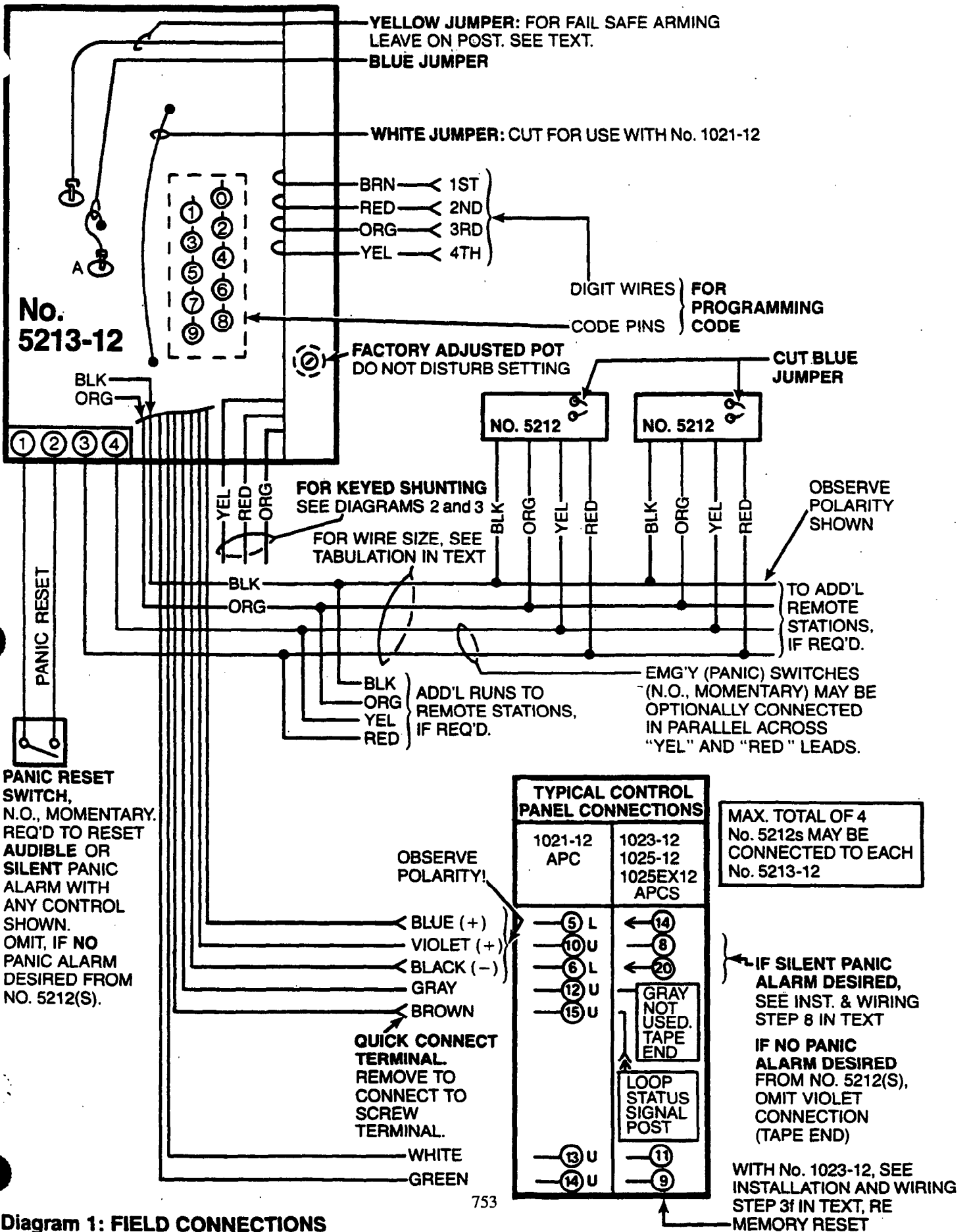
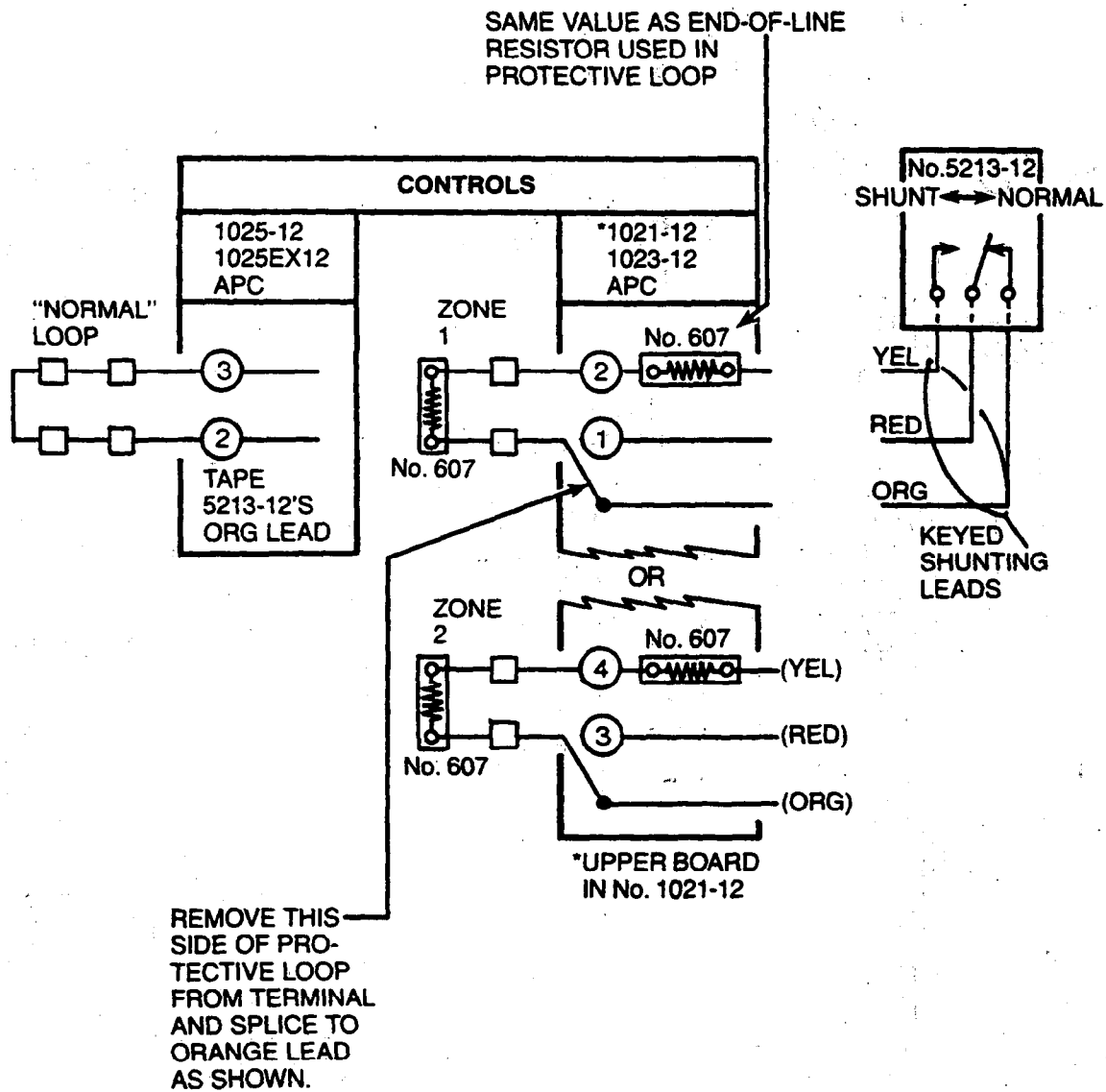
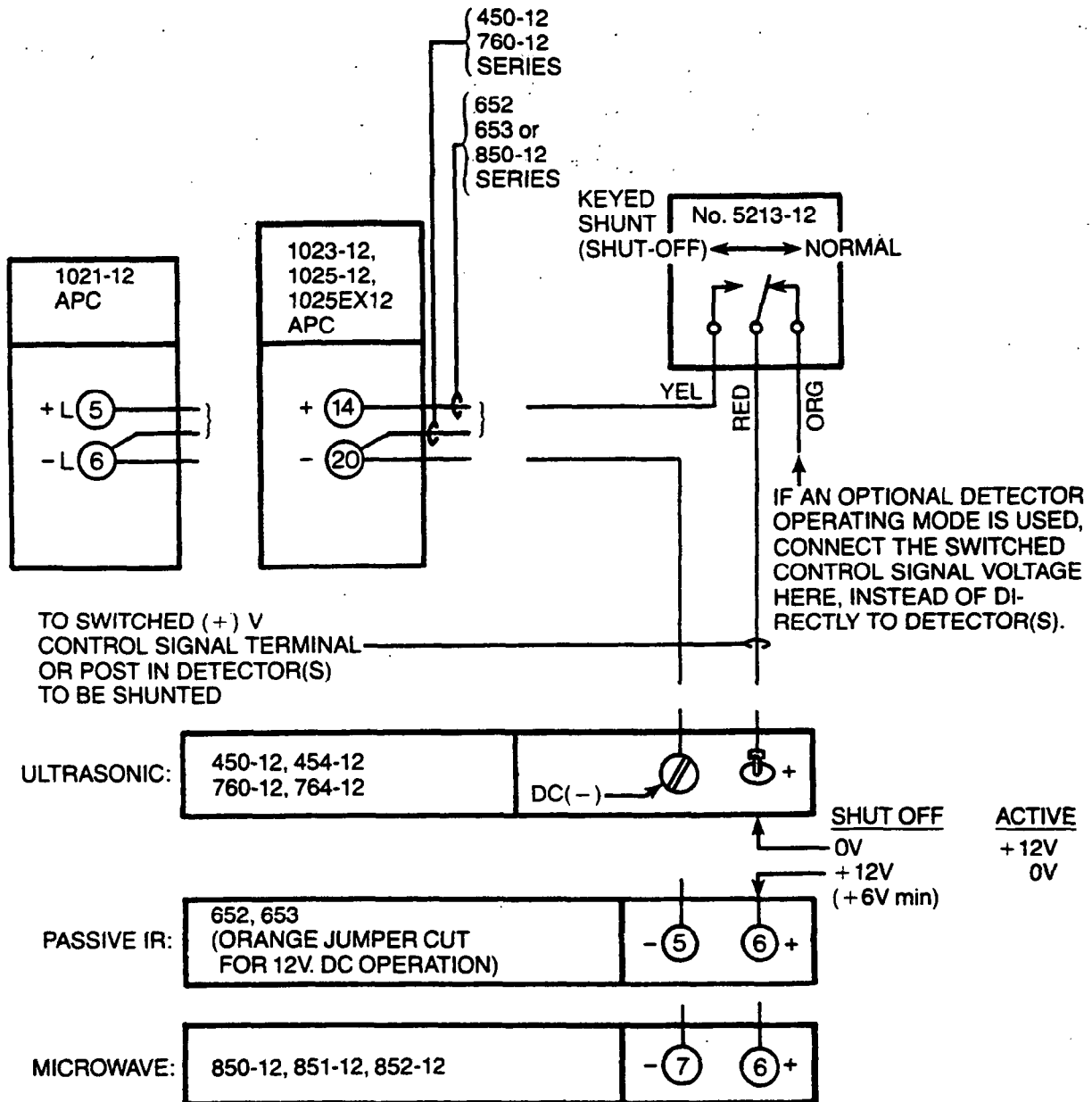

Diagram 1: FIELD CONNECTIONS



NOTE: DO NOT USE No. 5213-12 IN CONJUNCTION WITH A "FAST" RESPONSE ZONE.

Diagram 2: TYPICAL CONNECTIONS, KEYED SHUNTING OF SINGLE ZONE



Note: Keyed shunting (shutoff) as shown here is not applicable to passive infrared detectors such as the Nos. 650-12EX, 651-12EX, 652-12 and 653-12 in which the alarm relay is active at all times during the armed and disarmed periods.

Diagram 3: TYPICAL CONNECTIONS, KEYED SHUNTING (SHUTOFF) OF SPACE PROTECTION DEVICES