

ADEMCO

INSTALLATION INSTRUCTIONS

**No. 216-12
ADAPTER**

for Digital Remote Stations with Panic Circuitry
Single LED indication with No. 215-12 Remote Station(s)
or
Two LED indication with No. 5212 Remote Station(s)

GENERAL INFORMATION:

This No. 216-12 Adapter, when used with No. 215-12 or 5212 Digital Keypad Remote Station(s), permits coded pushbutton ON/OFF (ARM/DISARM) control of 12V alarm panels such as the Nos. 1021-12, 1023-12, 1025-12 and 1025EX12 Alarm Processing Centers and Nos. 4080-12, 4080EU and 4090 LogiCenters.

The No. 215-12 Remote Station provides single LED indication of the status of the control's burglar alarm circuit. Only two wires are required to connect up to four stations to the control.

The No. 5212 Remote Station provides two LED indication (a third LED on the station is for another application) and requires four wires for connection of up to four stations.

The No. 216-12 Adapter is shipped connected for QUICK ARM single digit arming and four digit disarming. Full 4 digit arming may be selected by cutting the GREEN jumper on the No. 216-12 (See WIRING Step 3c).

Nos. 215-12 AND 5212 Digital Remote Stations are for INDOOR use only.

DESCRIPTION:

A twelve pushbutton keypad on each remote station enables the user to arm or disarm the control or initiate a panic alarm at any time. Status of the control's burglar alarm circuit(s) (such as: "not ready for arming", "alarm memory", "ready for arming", or "armed") is indicated by a single RED LED on each No. 215-12 and by RED and GREEN LEDs on each No. 5212 used. An audible warning indicator is built into each remote station for use with the control's entry/exit delay circuit and other system warning sounds as the control or its other accessories may provide (see instructions accompanying those units.)

If desired, momentary type normally open emergency (panic) switches (e.g.: No. 219) may be connected across the remote stations' YELLOW AND RED leads instead of switches separately wired to the panel unless the remote stations' panic alarm feature is not to be connected. (See INSTALLATION AND WIRING Section.)

A "SILENT PANIC ALARM" connection option can be used, which utilizes the No. 216-12's panic circuitry to trip a digital communicator (e.g.: No. 669, 678 or 693) or dialer (e.g.: No. 612). A silent alarm can then be transmitted to a remote location when the appropriate pair of buttons on a No. 215-12 or 5212 Remote Station (or a panic switch connected to its circuit) is pressed. The special connections required are incorporated in the INSTALLATION AND WIRING Section herein.

The No. 216-12 Adapter's housing is designed to clip into the cabinet of the alarm control with which it is used. It contains a PC board which includes:

a) Leads for alarm control connections, b) "Digit Wires" and "Code Pins" for programming the 4 digit code, c) Jumpers for cutting or positioning as required, and d) Terminals for "Panic Reset" and remote station connections.

No tamper switches are needed in the remote stations as the system is inherently secure. A full four digit code is required to disarm the system and that code cannot be determined at any remote station.

- Notes:**
- A. Only No. 215-12 or No. 5212 Remote Stations (up to 4) may be used with the No. 216-12 Adapter.
 - B. Circuit safeguards will prevent arming or disarming by erasing all prior information entered via the keypad if: a) an erroneous digit is entered or, b) more than approximately 3 seconds are taken to enter the code.
 - C. Other remote stations (e.g.: Up to 4 Nos. 246, 246R or 5246) may be simultaneously, but independently, connected directly to No. 4080-12, 4080EU and 4090 LogiCenters.

D. A stand-alone keyswitch cannot be used for ON-OFF control of the panel when the No. 216-12 is used with an alarm processing center.

INSTALLATION AND WIRING (See Diagram 1):

Up to four No. 215-12 or 5212 Remote Stations may be connected to the No. 216-12 in parallel indoors, on one or more wire runs originating at the control (where the No. 216-12 will be located).

The wire size to be used for the entire length of a wire run depends upon the distance from the control to the farthest remote station on that particular run. Use the following tabulation to determine the wire size(s) needed for the proposed run(s). Twisted pair is recommended for greater immunity to unwanted induced voltages.

MAXIMUM DISTANCE TO FARTHEST REMOTE STATION	WIRE SIZE	ADEMCO NO. (TWISTED PAIR)	
		to No. 215-12	to No. 5212
100 feet	#22	No. 289	2 No. 289*
200	#20	No. 283	2 No. 283
300	#18	No. 284	2 No. 284
500	#16	No. 282	2 No. 282

* Alternatively, No. 295 (4 conductor) cable can be used.

If a No. 1025-12 or 1025EX12 Alarm Processing Center is being used, the remote station used at opening time should be located so that the ALARM MEMORY LED on the the alarm processing center can be viewed at opening time before the panel is disarmed (this LED will be lit if an alarm has taken place during the armed period). (Not relevant to other controls shown, as they have alarm memory by zone after disarming.)

IMPORTANT: Locate the remote station(s) where the buttons are not likely to be depressed accidentally, as this could lead to spurious arming (if single digit QUICK ARM is used) or false panic alarms.

An emergency (panic) alarm can be triggered at any No. 215-12 or 5212 Remote Station by momentarily pressing its buttons marked # and * simultaneously.

Note: If use of this feature is not desired, the No. 216-12's VIOLET lead may be left disconnected from the control unit during installation. See Step 8 in the following procedure.

1. Locate the Remote Station(s) and run the wiring between them and the control as described above. Connect each remote station's leads as shown in Diagram 1. Connections to the No. 216-12 Adapter (to be installed within the control) will be made later. In each No. 5212 Remote Station used, CUT THE BLUE JUMPER.
2. If desired, connect any number of momentary type N.O. emergency (panic) switches (e.g.: No. 219) across the "RED" and "YEL" run(s) to the remote station(s).

Note: If the Remote Stations' panic alarm feature is not to be connected as described earlier) emergency (panic) switches may only be connected on separate wiring to the control panel, in the standard manner, for audible panic alarm or directly to a digital communicator if SILENT PANIC ALARM is used (see WIRING Step 8).

3. Remove the cover from the No. 216-12 Adapter (grasp the cover at the wiring opening and pull firmly) and program its PC board as follows:
 - a. Select a four digit "disarm" code. The code may consist of any 4 different digits from 0 to 9 (e.g.: 2 1 5 8). Codes containing repeated digits (such as: 4 3 3 7 or 6 5 4 6) cannot be used.
 - b. Place the four "digit wires" on the appropriate "code pins". The BROWN "digit wire" should be placed on the "code pin" corresponding to the first digit in the selected code (e.g.: Pin 2, if 2 1 5 8 is the selected code). Similarly, the RED, ORANGE, and YELLOW wires should be placed on the pins corresponding to the 2nd, 3rd and 4th digits respectively. All four "digit wires" must be connected for proper operation.
 - c. Full four digit ARMING may be desired as well. The system normally will arm upon the pressing of only the first digit of the programmed four digit disarm code at a No. 215-12 or 5212 Remote Station. (This is particularly useful if the system will normally be armed by personnel not authorized to have knowledge of the full four digit disarm code.)
If, however, full four digit ARMING is desired, cut and remove the 2" GREEN jumper from the No. 216-12 circuit board. The system will then require the full four digit code to be pressed before arming takes place.
 - d. If a LogiCenter or No. 1021-12 APC is being used, cut the 4" "WHITE" jumper on the PC board and tape the cut ends.
 - e. DO NOT DISTURB THE FACTORY ADJUSTED POTENTIOMETER ON THE No. 216-12's PC BOARD.

f. The BLUE jumper in the No. 216-12 should be on the pin at position "A" in Diagram 1 when the No. 216-12 is used with one of the APCs shown and on the pin at position "B" when used with a LogiCenter.

4. Disconnect the control's battery and AC power.

5. Connect the remote station wiring to the No. 216-12, observing the "polarity" as shown in the diagram. Allow enough slack to reach the final position the No. 216-12 will occupy in the control.

Note: The cover of the No. 216-12 is provided with a mounting lip which can be slipped over the edge of the control cabinet, (during Step 7) without interfering with the closing of the cabinet's cover.

IF THE NO. 215-12's OR 5212's PANIC ALARM FEATURE IS NOT TO BE CONNECTED (AS DESCRIBED EARLIER IN THIS SECTION) SKIP THE FOLLOWING STEP 6, AND PROCEED TO STEP 7.

6. Connect Panic Reset wiring between the No. 216-12 and the control as indicated in Diagram 1. With an alarm processing center, a N.O. momentary contact switch for Panic Reset must be provided. The knockout provided in the cover of the control may be used for mounting the switch, or it may be located remotely [suggested keyswitches: No. 2174-70 (flat key), No. 4073-70 (round key), No. 5073-70 (higher security, pick resistant) ... or simply a No. 8064 Pushbutton may be used].

If a LogiCenter is to be used, connect as shown. No separate reset switch is required.

7. Replace the cover of the No. 216-12 (dress all wires through the opening at one end of the cover) and install the unit inside the control cabinet by slipping its mounting lip over the edge of the cabinet.

8. Connect the No. 216-12's remaining leads to the control as indicated in Diagram 1.

CAUTIONS: The BLUE (+) BLACK (-) leads supply power to the No. 216-12. Polarity must be observed or a burnout will result.

The VIOLET lead must not contact ground or any point other than called for in the diagram or a burnout may result. If it is not used (see next paragraph), tape its end.

Notes: If the Remote Stations' panic alarm feature is not to be used (as described earlier in this section) do not connect the No. 216-12's VIOLET wire (nor a LogiCenter's "panic reset" connection) but tape its end.

IF SILENT PANIC ALARM is desired (except for a LogiCenter) do not connect the VIOLET (+) lead to the control. Instead, connect the VIOLET (+) lead and the control terminal to which the BLACK (-) lead is also connected to the voltage triggering points of a digital communicator (a non-delay channel is recommended) or dialer. Observe polarity! (12V. DC appears across these leads when activated.)

AUDIBLE WARNING AT THE REMOTE STATION(S) IS RECOMMENDED FOR SECURITY AND USER CONVENIENCE PURPOSES, BUT...

If audible warning is not wanted at the Remote Station(s), do not connect the No. 216-12's GREEN wire.

If any No. 215-12 or 5212 is to be silenced while others are NOT, connect the No. 216-12's GREEN wire as shown in the diagram, but cut the thin ORANGE lead to the sounder in the No. 215-12 or 5212 that is to be silenced.

9. Reconnect the control's battery and A.C. power.

TESTING AND OPERATION:

Arming and disarming of the system may be carried out at any remote station.

When used with a LogiCenter, each remote station's LED(s) and buzzer will duplicate the actions of the SYSTEM STATUS LED and buzzer in the LogiCenter. For example, a flashing SYSTEM STATUS LED on the LogiCenter will be accompanied by a flashing LED on each No. 215-12 or a lit GREEN LED on each No. 5212.

The following tabulation shows how each remote station's LED(s) will indicate the system's status when used with a No. 1021-12, 1023-12, 1025-12 or 1025EX12 Alarm Processing Center.

REMOTE STATION'S LED(s)	SYSTEM STATUS
<p>No. 215-12: OFF</p> <p>No. 5212: GREEN: OFF RED: OFF</p> <p>(YELLOW NOT USED)</p>	<p>DISARMED, PROTECTIVE CIRCUIT(s) FAULTED or (with No. 1021-12 or 1023-12 APC) ALARM STORED IN PANEL'S MEMORY (see control's instructions).</p>
<p>With an Alarm Processing Center, LED(s) on APC will be lit for specific zone(s) not ready for arming or lit to indicate memory in a No. 1021-12 or 1023-12 alarmed zone which has restored (flashing on a No. 1023-12). The No. 1021-12 may have a panic alarm stored which is not indicated on the panel but is keeping the No. 215-12's single LED (or the No. 5212's GREEN LED) OFF.</p> <p>To clear the No. 1021-12's memory, press the RESET switch on the front of the 1021-12. The No. 215-12's LED will then start flashing (or the 5212's GREEN LED will turn ON).</p> <p>The No. 1023-12 Alarm Processing Center features automatic loop shunting and may be armed even though one or both of its basic protection zones (not the delay zone) has a fault, and the No. 215-12's LED is not flashing (or the No. 5212's GREEN LED is not ON).</p>	
<p>No. 215-12: FLASHING</p> <p>No. 5212: GREEN: ON RED: OFF</p> <p>(YELLOW NOT USED)</p>	<p>DISARMED, PROTECTIVE CIRCUIT(s) CLOSED (Ready for arming).</p>
<p>If the fire circuit of a No. 263-12 Fire Module is being used concurrently with a No. 216-12 and No. 215-12(s) or 5212(s) connected to a No. 1023-12, 1025-12 or 1025EX12 APC, the buzzer in each No. 215-12 (or 5212) will sound intermittently in the event of trouble in the fire loop while the system is disarmed (not applicable to No. 1021-12 APC).</p>	
<p>No. 215-12: ON STEADILY</p> <p>No. 5212: GREEN: OFF RED: ON</p> <p>(YELLOW NOT USED)</p>	<p>ARMED (Ready for Alarm or Disarming)</p>
<p>If the fire circuit of a No. 263-12 is being used concurrently with a No. 216-12 and No. 215-12(s) or 5212(s) connected to a No. 1023-12, 1025-12 or 1025EX12 APC, the buzzer in each No. 215-12 (or 5212) will sound steadily in the event of trouble in the fire loop while the system is armed (not applicable to the No. 1021-12 APC).</p>	

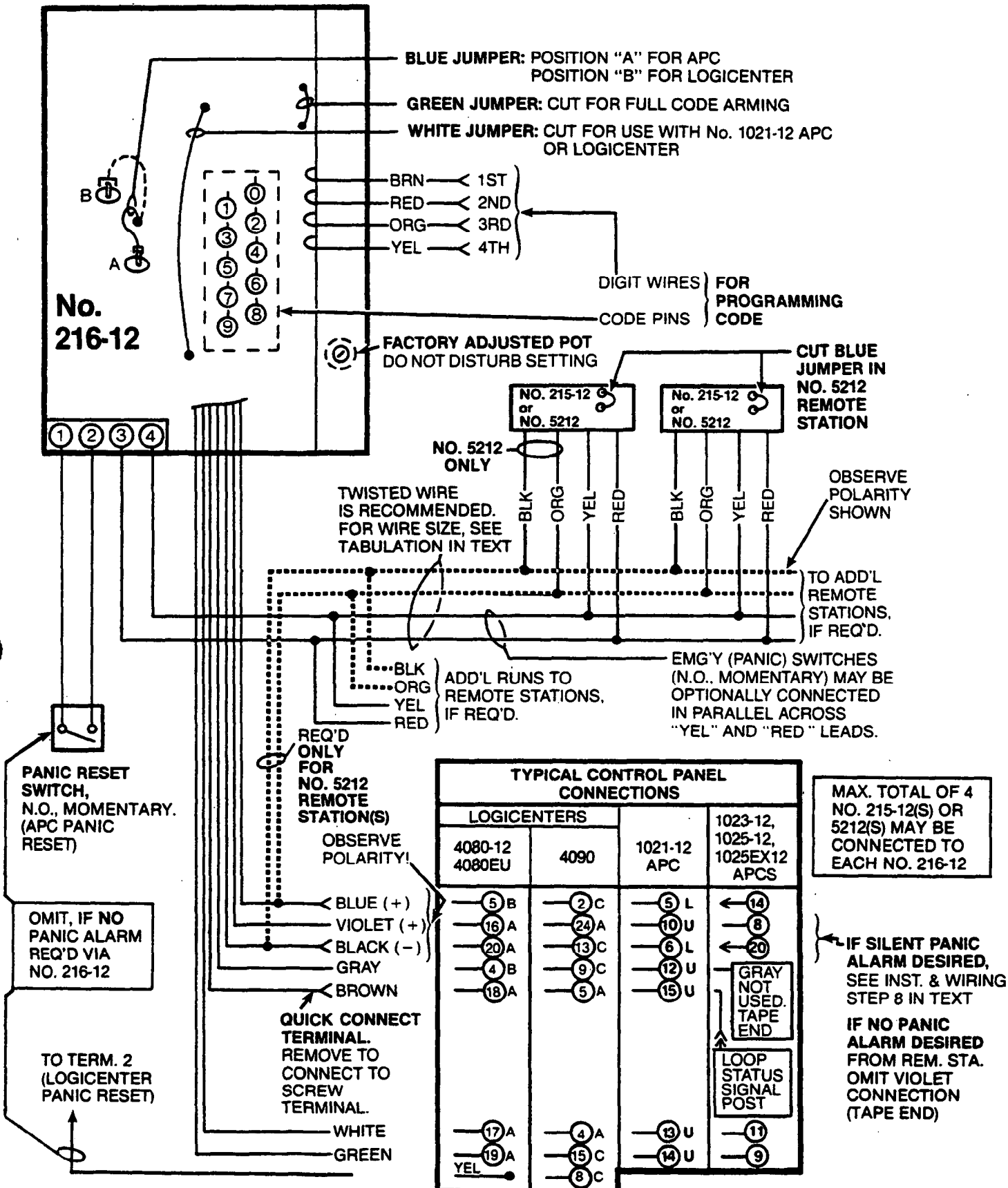

Diagram 1: FIELD CONNECTIONS

1. **Arm and disarm the system at each remote station and check the response of each station's LED indicator (see Note B on Page 1).**
 - a. Make sure all protective circuits are closed and the system is ready for arming (No. 215-12: LED flashing, No. 5212: GREEN LED ON).
 - b. Arm the system by entering the first digit of the 4 digit code at the remote station. Enter all four digits if "four digit arming" has been selected (No. 215-12: LED lights steadily, No. 5212: RED LED lights). Wait while the control's exit delay period runs its course.
 If a basic protection circuit (without entry/exit delay) is then disturbed, an alarm will sound immediately. If an entry/exit delay circuit is disturbed, the remote station's audible indicator will sound during the "entry delay" period. If the system is not disarmed before the entry period expires, an alarm will result.
 For buzzer warnings that occur during other than normal arming conditions, see the instructions that accompany the control.
 - c. Disarm the system by entering the entire 4 digit code at the remote station (No. 215-12: LED will go OFF or start flashing, No. 5212: RED LED will go OFF, GREEN LED, will be OFF or ON).
2. **Trigger Panic alarms as follows:**

Note: This assumes that the No. 216-12's VIOLET wire has not been left disconnected, to eliminate this feature, as described previously.

 - a. At a No. 215-12 or 5212 Remote Station, momentarily press the buttons marked # and * simultaneously. The panic alarm will sound (or a silent alarm will be sent) and continue until the PANIC RESET switch (with APC) is operated or the LogiCenter is reset. Repeat for each additional Remote Station.
 - b. If additional panic switches have been connected across the remote station wiring, test them as well.

SPECIFICATIONS:

	<u>No. 216-12</u>	<u>No. 215-12 or 5212</u>
Physical:	Width: 3-3/4" (9.5 cm)	2-7/8" (7.3 cm)
	Height: 6-7/8" (17.5 cm)	4-5/8" (11.7 cm)
	Depth: 1-1/4" (3.2 cm)	1" (2.5 cm)
Electrical:	No. 216-12 is powered with 12V. DC from control instrument.	
	Up to 4 No. 215-12s or 5212s may be connected to one No. 216-12.	
	Current Drain: 16mA for No. 216-12 plus 8mA per No. 215-12 (LED lit steadily) or No. 5212 (one LED lit).	

TO THE INSTALLER

Regular maintenance and inspection (at least annually) by the installer and frequent testing by the user are vital to continuous satisfactory operation of any alarm system.

The installer should assume the responsibility of developing and offering a regular maintenance program to the user as well as acquainting the user with the proper operation and limitations of the alarm system and its component parts. Recommendations must be included for a specific program of frequent testing (at least weekly) to insure the system's proper operation at all times.

ADEMCO

ALARM DEVICE MANUFACTURING CO.

A DIVISION OF PITTMAN CORPORATION

165 Eileen Way, Syosset, New York 11791