

GENERAL INFORMATION:

The No. 1034-12 Zone Expansion Center permits additional protection zones to be added to Nos. 1022-12 and 1023-12 Alarm Processing Centers. A single protection circuit in the main control may be expanded to four individually controlled zones by the addition of a No. 1034-12. Additional groups of four zones may be added by connecting up to four more No. 1034-12's in parallel with the first (see SPECIFICATIONS).

If desired, up to two of each No. 1034-12's four zones may be connected as 24 hour zones with "day" sounder annunciation of disturbances in permanently closed or seldom opened protection.

A remote warning sounder (No. 706-12 or buzzer in digital remote station) will also give audible notification of other than normal conditions in any zone at closing time. (Sounder not furnished.)

Outputs for individual zone triggering of a dialer or digital communicator and signalling zone loop status to remote stations are provided as well.

FUNCTIONAL DESCRIPTION:**Protection Zones:****1. GENERAL** (applicable to all zones):

- a. Protective Loops: Four two wire zone loops are provided. Each is supervised and employs a 2000 ohm End-of-Line resistor. There may be up to 400 ohms of resistance in each loop (excluding the EOL resistor). Each loop may contain closed circuit (in series) or open circuit (in parallel) contacts in any combination.
- b. Response Times: Each zone loop normally provides a 250ms (millisecond) response time (swingers, transients or momentary loop disturbances lasting less than 250ms will be ignored by the unit).

If a vibration contact or other fast responding device is used in one of the zone loops, cutting the ZONE RESPONSE JUMPER for that zone located on the unit's PC board (Zone 1: BROWN, 2: RED, 3: ORANGE, 4: YELLOW. See Diagram 1) will change the zone to the fast response mode (15ms).

- c. Zone ON-OFF Switches: Each zone has its own ON-OFF switch, which, if turned OFF, enables an unused or faulty protection zone to be ignored by the system. While the system is armed, these switches are supervised. A zone may be turned ON without incident, but an attempt to turn a zone OFF will trigger an alarm from that zone.
- d. Zone LED Indicators (with memory): Each zone has its own LED for circuit test purposes and zone annunciation. A loop disturbance after arming will cause the corresponding zone LED to light and remain lit until the system is disarmed. If the loop disturbance has by then cleared (or when it subsequently clears) the LED will turn OFF. If the zone is turned OFF, the LED will indicate the status of the zone at all times.

2. 24 HOUR ZONE OPTION (Available on Zones 1 & 2):

Zone 1 and/or 2 may be set up as 24 hour ("day" sounder; "night" alarm) zones if desired by cutting the appropriate 24 HOUR ZONE OPTION JUMPER(S) located on the unit's PC board (Zone 1: GREEN, Zone 2: BLUE. See Diagram 1).

If the zone loop is disturbed during the "day" (system disarmed) period, the external sounder (No. 706-12) connected to the No. 1034-12 will turn on and stay on. After 2 seconds the sounder may be silenced by momentarily closing a N.O. switch (see WIRING Step 4a for suggested switches that may be used).

The sounder will also be triggered if an attempt is made to turn off a 24 hour zone during the "day". Sound will continue for at least 2 seconds (should someone operate the reset switch immediately) or until the reset switch is operated.

No alarm will be initiated, of course, while the system is disarmed. While the system is armed, disturbance of any zone or an attempt to turn OFF a zone switch will result in an alarm as described next under "Outputs".

Outputs:

1. PROTECTION ZONE OUTPUT (Terminal 14):

This output is connected to (one of) the protective circuit(s) on the main control panel. No other protection should be connected to this circuit.

To PREVENT AN ALARM, any No. 1034-12 zone with a fault must be switched OFF before the main control is armed. If an attempt is made to arm the system with one of the No. 1034-12's zones in a fault condition, but turned ON, the remote sounder will sound for five seconds to alert the subscriber to the condition. Unless the main control is turned OFF within five seconds AN ALARM WILL BE TRIGGERED. The five second delay is also important since it prevents controls with automatic zone shunting (such as the No. 1022-12 and 1023-12) from setting up initially with the basic protection zone (to which the No. 1034-12 is connected) shunted out because of the alarm condition.

While the system is armed, if a fault occurs on any of the No. 1034-12's ON zone loops (or an ON zone loop of any additional paralleled No. 1034-12's) or if an ON zone switch is turned OFF, a short will appear from this output to the negative (-) protection circuit terminal for two seconds and then clear. Subsequent zone disturbances will cause additional output shorts of two seconds duration.

2. "DIALER" TRIGGER OUTPUTS (12V. DC, 5 ma):

- a. Individual Zones 1-4: Each zone has an individual "DIALER" TRIGGER OUTPUT post associated with it on the PC board (see Diagram 1) that may be connected to the voltage triggering connection points of a dialer or digital communicator. The triggers are enabled five seconds after the system is armed. A subsequent disturbance on any ON zone loop, including an attempt to turn OFF a loop, will generate a two second 12V. DC output at the associated post. If a digital communicator is used, the channel selected should be set for "non-abort" operation, and programmed to an alarm code.

- b. "Zone Shunted (OFF) at Arming" Output (Post 5): This DIALER TRIGGER OUTPUT POST (see Diagram 1) is intended to trip a dialer or digital communicator if the system has been armed with any of the zones OFF. It is enabled five seconds after the system is armed and, when tripped, provides a steady 12V. DC output. If a digital communicator is used, connection should be made to a channel that has been set for the "abort" mode and programmed to a lower than alarm priority code that will tell the central monitoring station that arming has taken place without all zones ON.

THIS TRIGGER WILL ALSO BE TRIPPED IF ANY ZONE LOOP GOES INTO A STEADY FAULT CONDITION AFTER ARMING OR ANY ZONE SWITCH IS SUBSEQUENTLY TURNED OFF. Alarm output signals simultaneously appearing on the appropriate individual zone post(s) will take priority, however, if programmed as higher priority codes on a digital communicator.

3. SOUNDING DEVICE OUTPUTS:

Two types of outputs for a sounding device (e.g.: No. 706-12 Mini-Howler) are provided:

- a. Directly Powered, Terminals 10 (-), 13 (+) (12V. 25 ma): These terminals can power one No. 706-12 directly with a two wire hookup and should be used in conjunction with the No. 1022-12 Alarm Processing Center as shown in Diagram 2.
- b. "Buzzer" Signal Post is a low current output to be used in conjunction with the No. 1023-12 Alarm Processing Center so that accessories used may receive signals from the No. 1034-12. In this instance a three wire connection is required for the No. 706-12 Mini-Howler to be connected to the No. 1034-12. See Diagram 3.

With either output, the No. 1034-12's remote sounding device (No. 706-12) will be activated at the following times:

- 1) If the 24 hour zone option has been selected and the zone is disturbed or someone attempts to turn it OFF. This will occur only when the system is disarmed.

Note: The buzzers in two wire remote stations such as the No. 215-12 (used with the No. 1023-12 panel) will not function as 24 hour warning sounders. They will function for all other sounder signals produced by the No. 1034-12. The buzzer in a No. 5241 Self-Contained Remote Station will function as a day buzzer.

- 2) If the system is armed with a zone switch OFF, the No. 706-12 will sound for five seconds and then shut off. This serves as a reminder that all is not normal in the system.
- 3) If the system is made to arm the system with an ON zone in a fault condition, the No. 706-12 will sound for five seconds AFTER WHICH AN ALARM WILL BE TRIGGERED, unless the system is disarmed during those five seconds. The system should be disarmed, the problem corrected (or the zone turned OFF) and the system rearmed.

4. STATUS OUTPUT (Terminal 16):

This output is used with a No. 1023-12 panel utilizing single LED remote stations or the No. 5241-12 Remote Station. It will indicate at each remote station (status LED will be OFF) if any of the ON loops are in a fault condition. See Diagram 3.

5. SYSTEM ARMED LED:

This LED lights when the five second delay at arming time has elapsed and the "dialer" triggers are enabled.

Additional Feature:

SUPERVISED PROTECTION ZONE OUTPUT AND POWER WIRES:

If the protection zone output wires from terminals 14 and 15 to the control are cut or shorted together during the armed period, an alarm will be initiated at the control. This also applies to the wires bringing power from the control to terminals 9 and 10 of the No. 1034-12.

INSTALLATION AND WIRING:

1. Select locations for the No. 1034-12 and the No. 706-12. The No. 1034-12 should be located near the main control. The sounder may be located in any convenient location where it may be heard at the control and elsewhere as required if any 24 hour zones are used.
2. Wire the No. 1034-12's protection zones to terminals 1 through 8 in accordance with Diagram 1, the "Protection Zones" information in the FUNCTIONAL DESCRIPTION section, and the following summary:
 - a. Use Zones 1 and/or 2 as 24 hour zones, if desired. If used, cut appropriate 24 HOUR ZONE OPTION JUMPER: 1-GREEN, 2-BLUE.
 - b. Open and/or closed circuit contacts may be used. For "fast" zone response, cut appropriate ZONE RESPONSE JUMPER(S): 1-BROWN, 2-RED, 3-ORANGE, 4-YELLOW.
 - c. Maximum allowable loop resistance (excluding end-of-line resistor) is 400 ohms.
 - d. If a zone is not used, connect 2000 ohm end-of-line resistor directly across protection zone terminals.
3. BEFORE PROCEEDING FURTHER, DISCONNECT THE BATTERY AND A.C. POWER FROM THE MAIN CONTROL PANEL.
4. Connect wiring between the No. 1034-12 and the main control panel, sounder and (if needed) 24 hour zone reset switch in accordance with the appropriate Diagram 2 or 3 and the following:
 - a. A "24 Hour Zone Reset Switch" (N.O., momentary) is required only if the optional 24 hour zone operation has been selected. Suggested switches: No. 2174-70 (flat key), No. 4073-70 (round key), No. 5073-70 (higher security, pick resistant)...or simply a No. 8064 Pushbutton may be used.
 - b. No separate end-of-line resistor is required for the main panel's protective loop.
 - c. Additional No. 1034-12's may be paralleled with the first (up to four more... see SPECIFICATIONS) by connecting terminals 9, 10, 11, 12, 13, 15 and 16 (not

14) of the first unit to the correspondingly numbered terminals on each additional unit. No other connections to these terminals are required on the additional units. NO CONNECTION SHOULD BE MADE TO TERMINAL 14 ON ANY OF THE ADDITIONAL UNITS.

The protection zones (terminals 1 through 8) of each additional No. 1034-12 may be connected similarly to, but independently of, those for the first unit. Optional 24 hour zone operation is available for zones 1 and 2 of each unit and normal or fast response can be selected for any zone by cutting the appropriate jumpers.

5. If connection is to be made to a dialer or digital communicator, refer to the "DIALER" TRIGGER OUTPUTS information in the FUNCTIONAL DESCRIPTION section. As indicated in Diagram 1, the desired "DIALER" TRIGGER OUTPUT POST(S) (+) and terminal 10 (-) of the No. 1034-12 should be connected to the voltage triggering terminals of the dialer or digital communicator. Observe polarity!
6. Leave battery and A.C. power disconnected from the main control until ready for TESTING AND OPERATION.

TESTING AND OPERATION:

If the No. 1034-12 has been connected to a dialer or digital communicator, it is suggested that the latter be disconnected during initial testing of the No. 1034-12, in order to avoid transmission of unwanted messages.

1. Place the main control in the disarmed (OFF) mode and connect its battery and A.C. power. The No. 706-12 may sound. If it does, turn it off by closing the 24 hour zone reset switch momentarily (or short terminals 11 and 12 on the No. 1034-12 momentarily).
2. Place the No. 1034-12's zone switches in the ON position. All of the zone LED's should be off. If any are lit, check the appropriate zone loop wiring (its resistance, including end-of-line resistor should measure between 2000 and 2400 ohms).
3. The main control's red zone LED corresponding to basic protection zone 1 should be off. If this condition is not present, check the main protective loop wiring between the No. 1034-12 and the main control.
4. Use a wire to short the No. 1034-12's No. 1 zone loop terminals (1, 2) momentarily. The zone 1 LED should light while the short is applied. The alarm processing center's basic protection zone 1 LED should come on for 2 seconds and go off. If the zone is set as a 24 hour zone, the No. 706-12 will sound. It may be silenced by operating the 24 hour zone reset switch (or shorting terminals 11 and 12) momentarily.
5. Repeat Step 4 for each of the other No. 1034-12 zones (including zones on paralleled No. 1034-12's if used).
6. If remote stations are used with the main control that indicate protective loop status (such as the No. 5241-12 or those using, for example, No. 244-12, 245-12 or 216-12 Adapters), conduct a STATUS OUTPUT TEST as follows:

- a. Observe the status LED at a remote station. It should be flashing, indicating all loops are normal (the No. 5241-12's GREEN LED will light steadily).
 - b. Short one of the zone loops at the No. 1034-12 (e.g.: Zone 3 terminals 5 and 6.) The zone LED in the No. 1034-12 should light and the flashing LED (or No. 5241-12's lit GREEN LED) on the remote station should go out. Note: If zone 1 or 2 is shorted and it is set up as a 24 hour zone, the remote sounder will be tripped. Silence it as described in Step 4, after the short is removed in Step 6c below.
 - c. Remove the short. The zone LED should go out and the remote station LED should resume flashing (No. 5241-12's GREEN LED lights).
7. Turn OFF one of the No. 1034-12's zone switches, wait at least 2 seconds, and ARM the main control. The remote sounders (and buzzers, if any) should sound for approximately 5 seconds and then stop. The No. 1034-12's SYSTEM ARMED LED should light after 5 seconds.

Zone ON-OFF Switch Note: To AVOID TRIGGERING AN ALARM, zones should be turned OFF only while the main control is DISARMED. The system should not be ARMED for at least 2 seconds after turning a zone OFF (on No. 1022-12 and 1023-12 Alarm Processing Centers, the zone 1 LED should have gone out, and on systems with remote stations the status LED should have resumed flashing. No. 5241-12's GREEN LED will light steadily.).

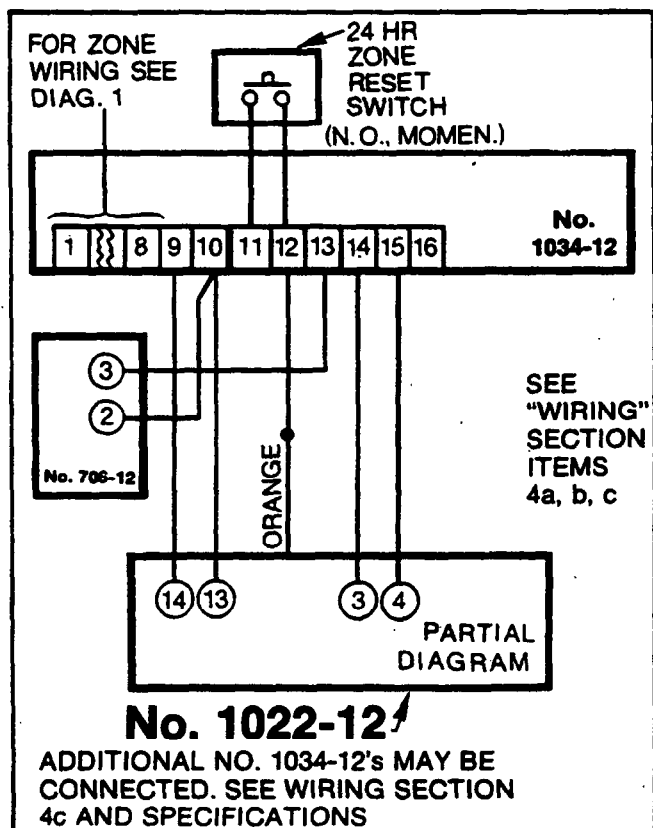

Diagram 2: No. 1022-12 A.P.C.

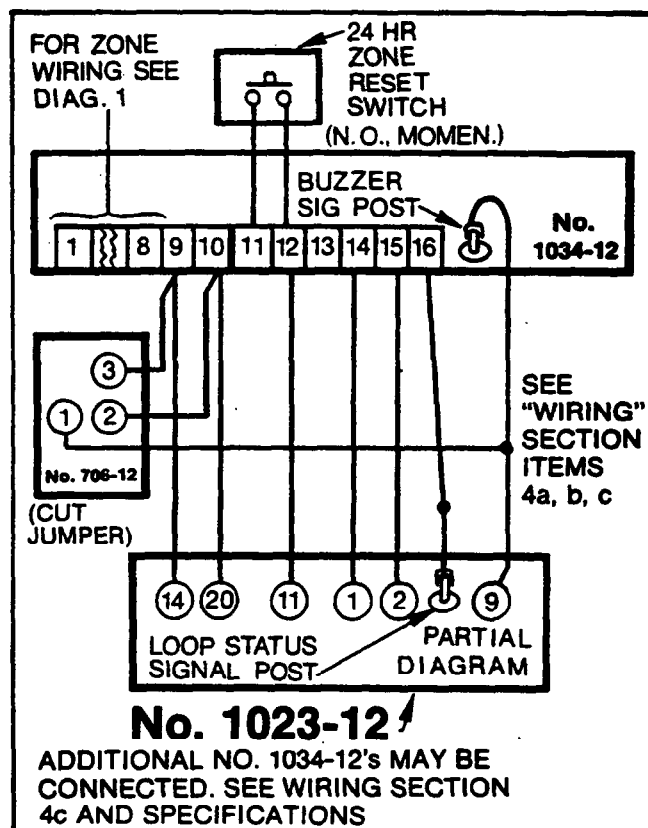

Diagram 3: No. 1023-12 A.P.C.

SPECIFICATIONS:

Physical:
Width: 8" (20.3 cm)
Height: 8" (20.3 cm)
Depth: 2" (5.1 cm)

Electrical: The No. 1034-12 is powered with 12V. DC (filtered only) from the control instrument. See the GENERAL INFORMATION section for controls with which it may be used.

Current Drain: Approximately 20 ma at 12V. (per No. 1034-12...SYSTEM ARMED LED ON, all others OFF).

The number of No. 1034-12's that may be connected in parallel (up to a maximum of 5) is determined by the output current available from the control less the current drain of its accessories. See WIRING section 4c.

TO THE INSTALLER

Regular maintenance by the installer and frequent testing by the user is vital to continuous satisfactory operation of any alarm system.

The installer should assume the responsibility of developing and offering a regular maintenance program to the user as well as acquainting the user with the proper operation and limitations of the alarm system and its component parts. Recommendations must be included for a specific program of frequent testing to insure the system's proper operation at all times.



ALARM DEVICE MANUFACTURING CO.

A DIVISION OF PITTMAN CORPORATION

165 Eileen Way, Syosset, New York 11791