

INDEX

Sections:	Page
GENERAL INFORMATION	1
SYSTEM FEATURES	2
FUNCTIONAL DESCRIPTION	2
Switches	2
LED Indicators	2
Keypad	3
Audible Signals	3
INSTALLATION AND WIRING	4
Terminals	4
Programming	6
Option Selection	6
Additional Connection Posts	6
SYSTEM CHECKOUT	7
OPERATION	8
To Arm Burglary System	8
To Disarm Burglary System	8
To Test Fire System	8
To Test Burglary System	8
To Initiate Panic Alarm	9
To Manually Initiate a Fire Alarm	9
Audible and Visual Indications	9
TURNING SYSTEM OVER TO SUBSCRIBER	9
GENERAL SPECIFICATIONS	9
Physical	9
Electrical	9

Illustrations:

Diagram 1: SIREN SPEAKER CONFIGURATIONS	5
Diagram 2: 1021-12 RESIDENTIAL ALARM PROCESSING CENTER	10
Diagram 3: 4021-12 RESIDENTIAL ALARM PROCESSING CENTER	11
Diagram 4: 5240-12 REMOTE COMMAND STATION	12
Diagram 5: No. 5240 ARM/DISARM CODE PROGRAMMING	13
Diagram 6: SYSTEM FIELD CONNECTIONS	14
Diagram 7: ALTERNATIVE ARM/DISARM CONFIGURATION, USING KEYSWITCH(ES)/PUSHBUTTON(S)	15

GENERAL INFORMATION:

A typical Residential Alarm System installation includes a No. 1021-12/4021-12 type Residential Alarm Processing Center and a maximum of four No. 5240-12 Digital Keypad Stations (including the one preinstalled in the No. 4021-12).

The No. 1021-12/4021-12 Residential Alarm System monitors all inputs and generates appropriate output signals. It provides 3 supervised zones of burglary protection, a supervised fire zone, and a twenty-four hour emergency circuit (silent emergency or audible panic). It also provides zone status and alarm memory indications. The entry delay may be reduced to zero. A built-in speaker in the No. 4021-12 provides audible alarm annunciation.

The No. 5240-12 Digital Keypad Station(s) permit arming and disarming of the system as well as providing arming/disarming status indication. A silent (or audible) emergency (panic) alarm may also be triggered and the interior zone may be turned OFF and then ON from the Digital Keypad Station(s). A built-in buzzer provides audible trouble annunciation.

Alternatively, keyswitch(es)/pushbutton(s) may be used for arming/disarming, either alone or intermixed with keypad stations (at a maximum of 4 locations). Although these instructions primarily discuss the use of keypad arming/disarming, Diagram 7 indicates how keyswitches/pushbuttons may be used. Note that a No. 706-12 Mini-Howler will be required for pre-alarm warning, entry delay and fire trouble signals if keyswitches/pushbuttons are used.

SYSTEM FEATURES:

Fail-safe arming. The system may not be armed with any of its zones in a faulted condition. If the fault is not cleared and an attempt to arm the system is made, a 3 second audible warning tone will sound.

Keypad arming/disarming with four digit arming and four digit disarming:

Entry/Exit Zone with delay feature. Delay times may be set to 30 or 45 seconds. In addition, the entry time may be reduced to 0 by operating a switch on the No. 1021-12/4021-12. This zone accommodates closed circuit contacts (two wire circuit).

Perimeter Zone for normal and fast acting open or closed circuit devices (two wire circuit with end-of-line resistor).

Interior Zone for normal and fast acting open or closed circuit devices (two wire circuit with end-of-line resistor). This zone may be turned OFF remotely (at the No. 5240-12) within 3 seconds after the system's arming code is keyed.

24 Hour latching panic input for open circuit switches (such as No. 219 or No. 4023). This circuit may also be triggered from the No. 5240-12 by pressing the * and # keys thereon. The panic function is selectable as audible or silent.

Supervised 24 hour fire circuit with LED alarm and trouble indication and audible trouble annunciation at the No. 5240-12. In addition, a power output for smoke or products of combustion detectors is provided (interruptible on reset).

Supplementary output triggers for burglary, panic, and fire.

Arming status output is available as + 12 volts with the system armed and 0 volts with the system disarmed, or vice versa.

RED and GREEN LEDs at each No. 5240-12 remote arming point, to indicate system arming and loop status respectively.

Built-in siren driver for external speakers with different sounds for fire and burglary/audible panic.

Zone LEDs to indicate the status of each zone.

A.C. Power LED to indicate that A.C. power is available and the battery is being charged.

FIRE TEST/RESET Switch to check the fire system functions.

Automatic alarm cutoff and reset for burglary, panic, and fire (8, 12, 16, or 24 minutes).

12V. DC Power available continuously for powering digital keypad stations, etc. and interruptible for smoke detectors.

FUNCTIONAL DESCRIPTION: (See Diagrams 2 and 3)

Switches:

ENTRY DELAY ON/OFF Switch (INSTANT OFF/ON on 4021-12): To set the entry delay to zero, move the switch down momentarily (LED lit). To restore it to the selected time, move it up momentarily (LED out). This switch is operative only when the system is armed. A safety feature, however, automatically restores the entry delay at disarming time. This prevents the user from subsequently arming the system and leaving the premises without restoring the entry delay, thereby causing an alarm upon re-entry.

FIRE TEST/RESET Switch: This switch shorts the fire loop to initiate an alarm when momentarily pushed upward to TEST position. The main alarm sounder should function, giving an indication of battery condition. The FIRE TEST is reset by operating the FIRE TEST/RESET switch momentarily downward to RESET position. This downward operation resets the fire circuit and smoke detectors powered by the system. In addition, it is used to clear the memory of alarm in the system's zone status LEDs and in the panic circuit (reflected by absence of GREEN status LED indication at No. 5240-12 local or remote keypads).

EMERGENCY Pushbutton (a No. 4021-12 option): Depressing the BLUE Police Shield pushbutton will activate a panic alarm. The speaker in the No. 4021-12 and external speaker(s) will be activated (loud warbling speaker sound) immediately, if audible panic was selected. For both audible and silent panic, a supplemental output trigger will be immediately activated.

FIRE Pushbutton (a No. 4021-12 option): Depressing the RED Flame pushbutton will activate the fire alarm. The speaker in the No. 4021 and external speaker(s) will be activated (loud, steady speaker sound) immediately, as well as a fire indicating supplemental output trigger.

LED Indicators:

Fire LED (RED) This LED flashes to indicate trouble in the Fire zone. At the time that this occurs, the buzzer in the No. 5240-12 will begin to sound intermittently. These indications will remain until the fault is cleared.

The fault could have been caused by one of the following:

- a) A malfunction within a smoke or products of combustion detector.
- b) A break in one of the fire loop wires.
- c) A break in one of the wires supplying power to detectors.
- d) A blown auxiliary output current protection fuse.

Perimeter, Interior and Entry/Exit (Delay) Zone LEDs (RED): These LEDs indicate the status of their respective zones. A lit LED indicates that a loop is in a fault condition. Even when the Interior Zone is OFF, that zone's LED will still indicate status. These LEDs also provide a memory of alarm if a loop is faulted in the armed state and the fault restores. This memory remains until the FIRE TEST/RESET switch is moved momentarily to RESET.

ENTRY DELAY OFF (INSTANT ON) LED (AMBER): This LED lights to indicate that the entry delay has been set to zero by activation of the ENTRY DELAY switch to OFF (INSTANT switch to ON).

A.C. POWER LED (GREEN): Indicates that A.C. Power is present at the unit's input terminals.

Keypad, No. 5240-12: (See Diagrams 3 and 4)

This keypad is integral to the No. 4021-12 and is remotely located for the No. 1021-12 and optionally for the No. 4021-12.

Keys 1-9: These are used to enter the 4 digit arm/disarm/panic cutoff code.

Note: Audible panic cutoff is immediate when the code entry is made while the system is armed and occurs 3 seconds after code entry when the system is disarmed.

KEY 0: This key is used to turn off the Interior Zone if it is depressed within 3 seconds after the entry of the fourth digit of the arming code. This is useful when it is desired to arm the system with the premises occupied. The Perimeter and Entry/Exit (Delay) zones will then provide protection. Subsequent to this action, depression of the "0" key by itself will remove the Interior zone bypass. The Interior Zone may not be turned OFF after the system is armed. If it is desired to reapply the bypass, it would then be necessary to disarm the system and to repeat the initial arming/interior bypass function. A safety feature exists that automatically restores the Interior Zone at disarming time. This guards against the user inadvertently leaving the Interior Zone off indefinitely, reducing the level of protection provided.

*** and # Keys:** These, when activated simultaneously, will initiate a panic alarm.

Arming Status LED (RED): The burglary system's arming status will be indicated by this LED as follows:

LED INDICATOR	STATUS
Off	Disarmed
Flashing	Armed, Interior Zone OFF
On Steadily	Armed, All Zones ON

Protective Loop Status LED (GREEN): The burglary/emergency system's loop and memory of alarm status will be indicated by this LED as follows:

LED INDICATOR	STATUS
Off	<ol style="list-style-type: none"> 1. System Disarmed, Protective Circuits open (not ready for arming). 2. System Armed (Arming Status LED on steadily or flashing). 3. System Disarmed, Protective Circuits Intact but Memory or Alarm has not been cleared by activation of the FIRE RESET switch (not ready for arming). If no zone LEDs are lit, this is an indication that there had been a prior panic alarm tripped.
On	System Disarmed, Protective Circuits Intact (Ready for Arming).

Audible Signals:

No. 4021-12's Built-in Speaker:

FIRE ALARM: A loud, steady sound.

BURGLARY/AUDIBLE PANIC: A loud, warbling sound.

No. 5240-12's Buzzer:

FIRE TROUBLE: A pulsating, low level buzzing sound.

ENTRY WARNING: A steady, low level buzzing sound that is activated during the entry delay period.

ATTEMPT TO ARM SYSTEM WITH FAULTED ZONE OR ALARM IN MEMORY: A three second steady buzz will be activated after the arming code is entered. If the fault is in the Interior Zone and it is bypassed, the sound will cease and the system will arm. This sound serves to warn the user that the system will not be armed (because of the fail-safe arming feature) unless the fault is corrected. The LOOP STATUS LED will be OFF (disarmed, not ready for arming). The user should clear the faulty zone or alarm memory and then arm the system.

AUXILIARY POWER FUSE OPEN: A pulsating, low level buzzing sound if a No. 633-12 End-of-Line Relay Module is used in the fire circuit and the auxiliary power fuse opens. In effect, a fire trouble condition has been detected (See Item "d") under the description for the FIRE LED.

INSTALLATION AND WIRING:

Do not connect the battery or plug-in transformer until all other wiring has been completed.

Use of twisted wiring is recommended for all runs, for greater immunity to unwanted induced voltages.

Terminals: (See Diagram 6)

<u>Terminals on Upper Board</u>	<u>Description</u>
1,2 Perimeter Zone	<p>Burglary Protection Zones: For each zone, run a pair of wires from that zone's terminals to all protection points in the zone and terminate with a 2000 ohm End-of-Line Resistor (supplied). Each loop has normal response to closed circuit devices (such as magnetic contacts, foil, etc.) connected in series. In the Perimeter Zone, for fast response to quick acting devices (such as vibration contacts and photo-electric units without built-in delays), cut the YELLOW jumper wire on the unit's chassis (Interior Zone: Cut the RED wire for fast response).</p> <p>Note: If fast response is selected, the loop should not contain devices with exposed metallic contacts (to lessen the chance of false alarms)</p> <p>An open or short in the Interior or Perimeter loop will cause an immediate alarm when the system is ON.</p> <p>Devices with open circuit contacts (such as mats) may be connected between the wires of either loop. (Do not use an Ademco No. 602 Mat Coupler).</p> <p>Maximum permissible resistance in each loop: 300 ohms (plus the 2000 ohm End-of-Line Resistor).</p>
3,4 Interior Zone	
5,6 Entry/Exit (Delay) Zone	
7,8	<p>Burglary Protection Zone: For this zone, run a pair of wires from the zone's terminals to all protection points in the zone. The loop has normal response to closed circuit devices connected in series. An open in the loop will cause an alarm after the entry delay period has expired, unless the entry delay has been turned OFF via the ENTRY DELAY (INSTANT) switch.</p> <p>Fire Protection Zone:</p> <p>Run the supervised fire detection loop from these terminals to all U.L. Listed thermostats, smoke detectors, combustion detectors or other fire detection devices to be used. Runs up to 500 feet may be made with #22 wire. Run one continuous loop (no branches) through all devices, connecting any trouble relay contacts in series with the loop and normally open alarm contacts across the loop's two wires. At the last device, terminate the loop with the 2000 ohm end-of-line resistor (furnished) and a No. 633-12 Supervisory Module.</p> <p>Note: Low current smoke and/or combustion detectors such as the Nos. 622-12, 623-12 and No. 632H12 should be used. NFPA Standard No. 74 requires the use of at least one smoke or combustion detector in every residential installation.</p>
9,10	<p>Emergency Input: Connect open circuit momentary emergency switches (e.g.: Nos. 219 and 4023) in parallel across these terminals. If none are used, leave these terminals empty.</p> <p>Momentary operation of one of these switches at any time (system armed or disarmed) will cause the panic Supplemental Output Trigger to be produced. The integral speaker in the No. 4021-12 and the external siren speaker(s) will sound a loud warbling tone, if the audible option has been selected (see "Option Selection" later in this section).</p> <p>In order to obtain the ability to activate a panic alarm from a remote No. 5240-12 command station (* and # pressed simultaneously), the VIOLET lead from the No. 5240-12 must be connected to terminal 10.</p>
11-15	<p>Digital Keypad Stations: Connect No. 5240-12 Digital Keypad Station(s) as required and as indicated in Diagram 6. It should be noted that the Interior Zone Bypass capability requires that a wire be run from terminal 11 to the "0" code pin of the 10 pin programming connector on each No. 5240-12.</p>
16,17	<p>System Arming Status Supplemental Outputs: Terminal 16 will output 0V while the system is disarmed (OFF) and +12V while the system is armed (ON). Alternatively, terminal 17 provides 0V while the system is armed (ON) and +12V while disarmed (OFF).</p>

18

The output may be used to control space protection devices such as those in the 450 and 760 series (Ultrasonic), 650 series (Passive Infrared) and 850 series (microwave). See the individual instructions accompanying these devices.

Panic Supplemental Output Trigger: This outputs + 12 volts whenever an Emergency condition exists. It will return to 0 volts when the Arm/Disarm code is entered or after alarm cutoff. The GREEN Loop Status LED on the No. 5240-12 will not light after this output has been triggered until the FIRE RESET switch is operated.

19

Burglary Supplemental Output Trigger: This outputs + 12 volts in the event of a burglary zone alarm condition. It will return to 0 volts when the system is disarmed or at alarm cutoff time, whichever occurs first.

20

Fire Supplemental Output Trigger: This outputs + 12 volts in the event of a fire alarm. It will return to 0 volts when the FIRE TEST/RESET switch is operated to the RESET position or after alarm cutoff, whichever occurs first. (Note: This output will also be produced during a FIRE TEST).

Terminals on Lower Board

1(+),2(-)

12V. DC power for smoke (Nos. 622-12 or 623-12) or combustion (No. 632H12) detectors (interruptible by the FIRE RESET switch) may be obtained from these terminals. **Observe polarity.** Use wire sizes in accordance with the following tabulation and connect the power terminals of the detectors in parallel:

SMOKE OR COMBUSTION DETECTOR WIRING			
Maximum distance to farthest detector	Number of No. 622-12, 623-12 and/or 632H12's		
	1 or 2	3 to 6	7 to 10
100 feet	#22	#22	#20
200	#22	#20	#18
300	#22	#18	#16
500	#20	#16	*

*Use separate power runs for up to 6 detectors each.

Note: Do not exceed the auxiliary total output current limitations described under SPECIFICATIONS.

3,4

External Siren Speaker: 8 ohm (minimum) speakers rated 6W min. (e.g.: No. 705-8 or 713) may be used. Speakers may be connected singly or in series (for reduced individual sound intensity but spread over a wider area) with each speaker receiving half voltage.

Diagram 1 indicates the allowable speaker configurations for staying within the siren driver's current capability.

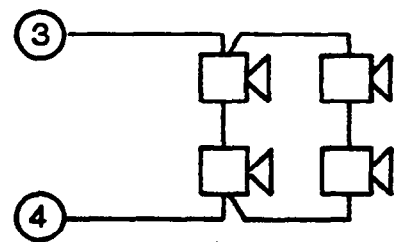
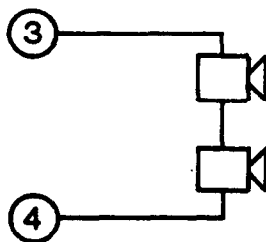
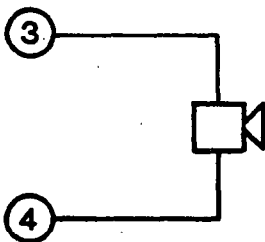

Diagram 1: 8 OHM SIREN SPEAKER CONFIGURATIONS

5(+),6(-)

Auxiliary Power Continuous 6V. DC is provided by these terminals for powering U.L. Listed devices such as ultrasonic (e.g. No. 760-12) or passive infrared detectors (e.g. 650-12EX), photoelectrics (e.g. No. 1325-12), etc.

The **total** combined current drain from these terminals and the smoke detector power terminals, (1 & 2) as well as to remote No. 5240-12s (if used) must not exceed 400 milliamps (see SPECIFICATIONS).

7,8

Power Input, 17V. AC: Connect these terminals to the output terminals of the No. 1321 Transformer.

Do not plug in the transformer yet, or connect the battery.

Ground

Ground lower board terminal 6 (-) to a cold water or electrical box earth ground. Use #18 AWG (minimum) stranded wire. On No. 1021-12, route via one of the cabinet's mounting screws.

Programming: (See Diagrams 5 and 6)

Arm/Disarm Code

1. **Select a four digit Arm/Disarm code.** The code may consist of any four digits from 1 to 9 (e.g.: 2158). Codes containing repeat digits may not be used (e.g.: 2258, 2553, etc.) Do not use zero (0).
Stations on multiple unit installations may be coded differently from each other, if desired.
2. **Program each No. 5240-12** for its assigned code, as follows. (Note: in the following example the No. 5240-12 is being programmed for code 5-2-4-9):
 - a. **Remove the No. 5240-12's cover (with a No. 4021-12, lift out the No. 5240-12 from the unit's base)** and position it so that the circuit board within the cover appears as shown in Diagram 5.
 - b. **Observe the "Code Digit Selection Wires",** the four 4 inch solid conductor wires at the left side of the circuit board. The colors are BROWN, RED, ORANGE and YELLOW.
 - c. **Observe the 10 pin connector** below the right edge of the PC board. Its holes are associated with digit values of 0 through 9 as indicated in Diagram 5. Note that the holes are not numbered sequentially.
 - d. **Simply insert the BROWN wire in the connector hole which corresponds to the numerical value selected for the first digit ("5" in Diagram 5's programmed example).**
 - e. **Similarly insert the RED, ORANGE and YELLOW wires in the holes for the 2nd, 3rd and 4th digits respectively ("2", "4" and "9" in Diagram 5's programmed example).**
 - f. **Insert five of the six WHITE wires into each remaining connector hole except for "0",** which will have a wire inserted that is connected to upper board terminal 11 for Interior Zone bypass. One WHITE wire will not be used. Tape its end.
 - g. **Replace the No. 5240-12's cover (reinstall the No. 5240-12 in the base of the No. 4021-12)** until ready to complete the installation.

Note: All four digits must be programmed (a 3 digit disarming code may not be used).

Entry/Exit Delay Selection: Entry/Exit delay may be programmed to be 30 or 45 seconds by means of a WHITE jumper connection. Refer to Diagram 6. Leave the jumper intact if 45 seconds is desired and cut it if 30 seconds is desired.

Alarm Sounder Cutoff Time Selection: The cutoff/automatic reset time for the sirens may be set to either 8, 12, 16, or 24 minutes. Refer to Diagram 6 or the table below.

JUMPERS		ALARM CUT OFF TIME (Minutes)	ENTRY/EXIT DELAY (Seconds)
WHITE	GREEN		
Cut	Intact	8	30
Intact	Intact	12	45
Cut	Cut	16	30
Intact	Cut	24	45

Option Selection: (See Diagram 6)

Panic Option: As supplied, the No. 1021-12/4021-12 is configured for AUDIBLE panic. If SILENT panic is desired, wherein only the panic supplementary output trigger is produced for a panic alarm, cut the BLUE jumper.

Zone Response Option: As supplied, the No. 1021-12/4021-12's zones are all configured for NORMAL (200 MSEC) response. If it is desired to employ fast acting devices (e.g. glass break sensors, photoelectrics without delay) in the Interior and/or the Perimeter Zones, the selected zone must be set for FAST (15 MSEC) response. Cut the YELLOW jumper for the Perimeter Zone. Cut the RED jumper for the Interior Zone.

Additional Connection Posts: (See Diagram 6)

Loop Status Input Post: Accepts an indication as to whether or not all of the unshunted burglary zones are intact from optional No. 1034-12 Zone Expansion Center(s).

Internal Speaker Output Posts: In the No. 4021-12, the built-in speaker will be preinstalled and wired to these posts. Not used in the No. 1021-12. In the No. 1021-12, an optional No. 701 speaker may be wired to terminals 3 and 4 on the lower board.

SYSTEM CHECKOUT:

Perform these tests after the wiring and option selections described in the previous sections have been completed.

1. **Connect the battery** in the No. 1021-12/4021-12 to the Molex connector on the panel's RED and BLACK leads.
Note: Check that the RED Arming Status LED at the No. 5240-12 is not lit. If it is lit, it should be extinguished by keying the ARM/DISARM code.
2. **Plug the transformer into a 120V. AC outlet that is ON 24 hours a day.** The A.C. POWER LED should light.
3. **Observe the ZONE STATUS LEDs.** None will be lit if the protective loops are properly wired and all contacts are properly set.
4. **When all ZONE STATUS LEDs are out, do the following and observe the appropriate LED light in each case.**
 - a. **Open the PERIMETER ZONE loop momentarily.** The PERIMETER ZONE LED should light while the loop is open. Repeat for the INTERIOR and DELAY ZONE loops and LEDs.
 - b. **Short the Perimeter Zone momentarily.** The Perimeter Zone LED should light while the loop is shorted. Repeat for the Interior Zone loop and LED.
5. **Observe the FIRE LED.** It should be OFF if the protective loop and detector power circuits are properly wired.
6. **Check the FIRE circuit operation as follows:**
 - a. **Disconnect one wire of the Fire loop.** The FIRE LED on the No. 1021-12/4021-12 should flash and an intermittent buzz should be heard from the No. 5240-12(s).
 - b. **Re-connect the Fire loop wire.** The FIRE LED should go out and the intermittent "buzz" should cease, indicating zone restore.
 - c. **Momentarily short the Fire loop.** A fire alarm should be triggered accompanied by a loud steady siren sound from both the internal (in the No. 4021-12) and external (if used) speakers. In addition, the FIRE LED should be lit steady.
Silence the alarm by momentarily activating the FIRE TEST/RESET switch to the RESET position.**Note:** The battery may not be fully charged. **If this test is tried with a low battery there will not be enough power to sound the external sirens.** Let the unit charge (transformer plugged in) for at least one-half hour if the battery is low.
7. **Test the Panic Circuit** by momentarily shorting terminals 9 and 10 or by operating a panic switch. The interior (in the No. 4021-12) and exterior speaker should sound (warbling siren sound) if the audible option is selected and the No. 5240-12's GREEN Loop Status LED should turn off. These conditions continue after the short is removed. Reset the circuit by keying the arm/disarm code* and then turn on the LED by momentarily activating the FIRE TEST/RESET switch to the RESET position.
***Note:** Cutoff will be immediate if the system was armed and will occur after 3 seconds if the system was disarmed.
8. **Arm the system** by entering the arming code at the keypad. The RED Arming Status LED should light steadily. Immediately depress the "0" key and the Arming Status LED will flash, indicating that the system has been armed with the Interior Zone turned off.
9. **Depress the ENTRY DELAY OFF (INSTANT) Switch on the No. 1021-12(4021-12).** The LED to the left of it should light. Disarm the system. Note that the ENTRY DELAY (INSTANT) and the Arming Status LEDs go out, indicating a restoral of the entry delay. The Interior Zone has also been restored.
10. **All the zone contacts may now be checked** by disturbing each contact in each zone and observing the status indicators.
11. **Arm the system and disturb a contact.** The warbling siren should sound.
12. **Disarm the system.**
13. **Check the operation of the supplementary output triggers.**
14. **Momentarily disconnect the AC power to the system.** The A.C. POWER LED on the No. 1021-12/4021-12 should go out but the system should remain operable.
15. **Arm the system and simulate leaving the premises** by following the procedure given in the OPERATION Section.
16. **Simulate entering the premises and disarm the system** by following the procedure given in the OPERATION Section.

OPERATION:

THE POWER LED ON THE No. 1021-12/4021-12 SHOULD BE LIT AT ALL TIMES. If out, A.C. failure is indicated and the system is operating on battery. Check plug-in transformer or for power failure (or call serviceman).

IMPORTANT: Wait at least 5 seconds between successive attempts at arming or disarming with the No. 5240-12 or it will not be possible to successfully enter the next disarm/arm code. **Exception:** The 5 second wait can be eliminated by keying any digit not used in the 4 digit code and then the code.

To Arm Burglary System:

1. Make sure the A.C. POWER LED is lit.
2. If remaining on premises after arming, the Interior Zone (see 4 below) and ENTRY DELAY may be turned OFF if desired.
Note: The Interior Zone may not be turned OFF after arming (although turning it ON is permissible). The ENTRY DELAY may be turned OFF only while the system is armed. It is turned ON by subsequent operation of the ENTRY DELAY (INSTANT) switch or automatically at arming time.
3. The GREEN Loop Status LED on the No. 5240-12 should be lit to indicate that the Perimeter, Interior and Entry/Exit (Delay) Zones are properly closed and the system is ready for arming.
If the Loop Status LED is NOT lit, check the ZONE STATUS LEDs on the No. 1021-12/4021-12. A lit zone LED indicates a fault or an alarm is in memory which must be cleared (or the INTERIOR turned OFF via the No. 5240-12 if the Interior Zone LED is lit and the problem can't be corrected) before the system can be armed. Make sure the exit door is closed! If no zone LEDs are lit and the Loop Status LED is NOT lit, it is an indication that alarm memory (i.e. panic) is still present. Activate the FIRE RESET switch downward to clear memory.
4. Enter the arming code at the No. 5240-12 (followed by "0" within 3 seconds if the Interior Zone is to be turned OFF). The RED Arming Status LED should light steadily (or flash if the Interior Zone is turned OFF). The Perimeter and Interior Zones arm immediately and the Entry/Exit (Delay) Zone's exit delay period begins.
If a three second steady buzz sounds at the No. 5240-12, it indicates that arming is being attempted with a faulted zone. If the fault is in the Interior Zone and the "0" key is depressed during the 3 seconds, the buzz will cease and the RED Arming Status LED will remain lit. If the buzz continues to its conclusion, the Arming Status LED will not stay lit and the system was not armed!
5. If leaving the premises, depart before the exit delay period ends, via the entry/exit door.

To Disarm Burglary System:

1. When entering the premises, enter only via the entry/exit door. A steady buzzing will sound (at a No. 5240-12) during the entry delay period. Go directly to a No. 5240-12 and enter the disarm code.
2. If already within the premises, enter the disarm code at a No. 5240-12.
3. Observe if any of the ZONE LEDs on the No. 1021-12/4021-12 are lit (will be lit if an intrusion alarm has taken place during the armed period). If the fault conditions are no longer present, operation of the FIRE TEST/RESET switch to the RESET position will turn off the ZONE LEDs.
Note: While the system is disarmed, the GREEN Loop Status and RED ZONE STATUS LEDs will go on and off as the protective loops open and close during normal operation of doors, windows, etc.

To Test Fire Systems:

The fire system should be tested at least every week.

Important: If the fire system is connected to a central monitoring station, they should be alerted before conducting any test.

1. Push the FIRE TEST/RESET switch on the No. 1021-12/4021-12 upward to Test and hold it. The fire alarm will sound (loud steady siren), the FIRE LED on the No. 1021-12/4021-12 will light and the fire alarm supplemental output trigger will be produced. During the test, the battery is checked by the sounding of the speakers from the battery. Release the switch; the sound should continue.
2. Reset the system by operating the FIRE TEST/RESET switch momentarily downward to the RESET position.

To Test Burglary System:

The burglary system should be tested as follows at least every month:

Important: If the system is connected to a central monitoring station, they should be alerted before conducting any test.

1. Arm the system.
2. Fault the Perimeter Zone by opening a protected window or other location.
3. The siren speaker in No. 4021-12 and any external speaker sounds immediately (loud, warbling sound) and the burglary supplemental output trigger activates.

4. Disarm the System.

To Initiate A Panic Alarm (at any time):

1. a. Depress a remote panic switch momentarily, or
b. At No. 4021-12, depress optional POLICE PANIC switch momentarily, or
c. Remotely or at No. 4021,-12 depress * and # keys simultaneously on No. 5240-12 momentarily:
Immediately, a loud, warbling siren will sound (if panic was selected as audible), the GREEN Loop Status LED on the No. 5240-12 will be turned off and the panic supplemental output trigger will activate.
2. To reset, enter the arm/disarm code at the No. 5240-12.

To Manually Initiate a Fire Alarm (at any time):

1. a. iDepress a remote open circuit fire panic switch, or
b. At No. 4021-12, depress optional FIRE PANIC switch momentarily, or
c. Push FIRE TEST/RESET switch upward, momentarily, at the No. 1021-12/4021-12.
Immediately, a loud steady siren will sound, the RED FIRE LED will light steady and the fire supplemental output trigger will activate.
2. To reset, push FIRE TEST/RESET switch downward, momentarily at the No. 1021-12/4021-12.

Audible and Visual Indications:

LOUD STEADY SIREN INDICATES FIRE ALARM. EXIT IMMEDIATELY. CALL FIRE DEPARTMENT. FIRE LED on No. 1021-12/4021-12 will be lit. To silence and reset after source of alarm eliminated, operate FIRE RESET switch. The Fire Alarm will also be silenced when the automatic alarm cutoff period expires if not previously silenced manually.

LOUD WARBLING SIREN: A) DURING DAY (SYSTEM DISARMED) INDICATES AUDIBLE PANIC ALARM, B) DURING NIGHT (SYSTEM ARMED) INDICATES BURGLARY ALARM OR AUDIBLE PANIC ALARM. Appropriate ZONE LED(s) will be lit. The alarm will silence when the automatic alarm cutoff period expires or when the system is disarmed, whichever occurs first.

LOW LEVEL PULSATING SOUND FROM No. 5240-12's BUZZER INDICATES FIRE SYSTEM ZONE TROUBLE. FIRE LED ON No. 1021-12/4021-12 will be flashing. When the trouble is cleared, the sound will be silenced and the FIRE LED will go out.

STEADY LOW LEVEL SOUND FROM No. 5240-12's BUZZER SOUNDS DURING ENTRY DELAY PERIOD.

STEADY LOW LEVEL BUZZ AT ARMING (LASTING FOR 3 SECONDS) INDICATES THAT SYSTEM HAS A FAULTED ZONE. AT THE END OF THIS PERIOD, THE SYSTEM WILL REVERT TO THE DISARMED STATE.

TURNING SYSTEM OVER TO SUBSCRIBER:

1. Fully explain the operation of the system to the subscriber by going through each of the features as well as the OWNERS MANUAL supplied.
2. Describe to him the operation of each zone. Clarify which zones are used at night and which contacts or devices are connected into the INTERIOR ZONE.
3. Encourage him to find and remedy his own bad loop when setting the alarm. Show him how to bypass the Interior Zone by using the "0" key on the No. 5240-12.

GENERAL SPECIFICATIONS:

Physical:

	No. 1021-12	No. 4021-12
Width:	8" (20.3 cm)	11" (27.9 cm)
Height:	15" (28.1 cm)	8" (20.3 cm)
Depth:	3" (7.6 cm)	3" (7.6 cm)

Electrical:

Voltage: 17V. AC (from No. 1321 Plug-In Transformer)

Current (per loop): 4 ma

Maximum Permissible Resistance (per loop): 300 Ohms (plus 2000 ohm end-of-line resistor, where used.)

Siren Driver Load: 8 ohms minimum (6 Watt minimum speaker rating)

Fuses: One 3 Amp fuse (No. 90-12) for fire and auxiliary power.
One 1 Amp fuse (No. 90-17) for siren speaker power.

Standby: 3 cell Sealed Lead Acid Rechargeable Battery.

No. 1021-12's battery: 2.5 AH (Ademco No. 496)—2 each

No. 4021-12's battery: 2.5 AH (Ademco No. 494)—2 each

Standby time is dependent upon continuous load supplied to accessories, including smoke and combustion detectors, and, if used, optional No. 5240-12 Remote Digital Keypads.

MAXIMUM STANDBY TIMES WITH VARIOUS AUXILIARY AND SMOKE/COMBUSTION DETECTOR CONTINUOUS LOADS*									
MA	0	50	100	150	200	250	300	350	400
HRS	100	32	18.5	13	9.5	7.5	6.5	5.5	4.5

ADDITIONAL TO PROCESSOR LOOP AND No. 5240-12 (ONE UNIT) CURRENTS.

* ADD 12 MA FOR EACH ADDITIONAL No. 5240-12 USED (IF ANY).

ADD 15 MA FOR EACH CUSTOM REMOTE PLATE USED (IF ANY).

TO THE INSTALLER

Regular maintenance and inspection (at least annually) by the installer and frequent testing by the user is vital to continuous satisfactory operation of any alarm system.

The installer should assume the responsibility of developing and offering a regular maintenance program to the user as well as acquainting the user with the proper operation and limitations of the alarm system and its component parts. Recommendations must be included for a specific program of frequent testing (at least annually) to insure the system's proper operation at all times.

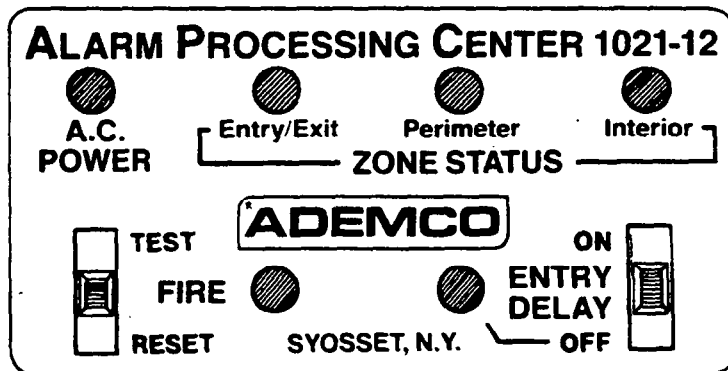

Diagram 2: No. 1021-12 RESIDENTIAL ALARM PROCESSING CENTER

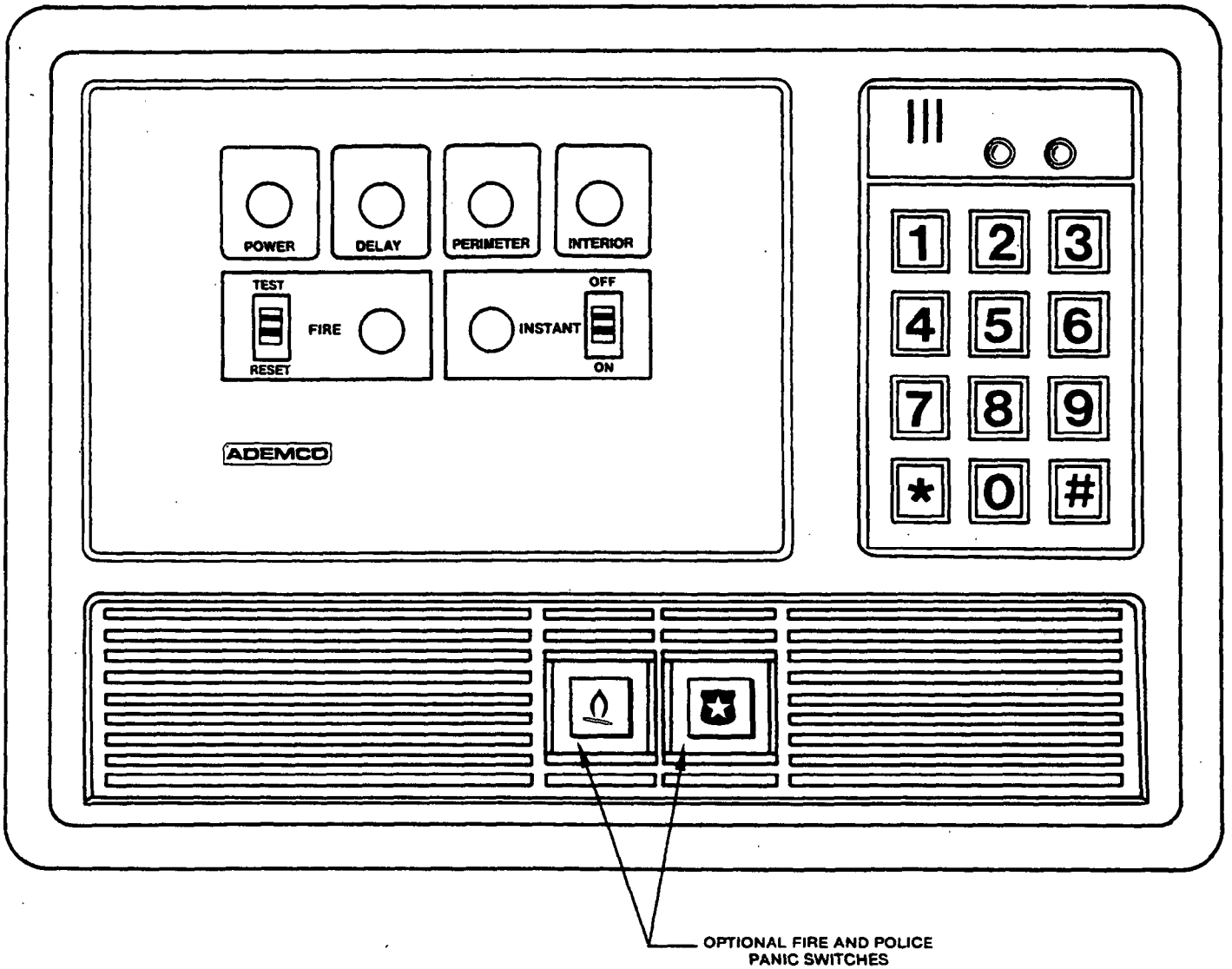

Diagram 3: No. 4021-12 RESIDENTIAL ALARM PROCESSING CENTER

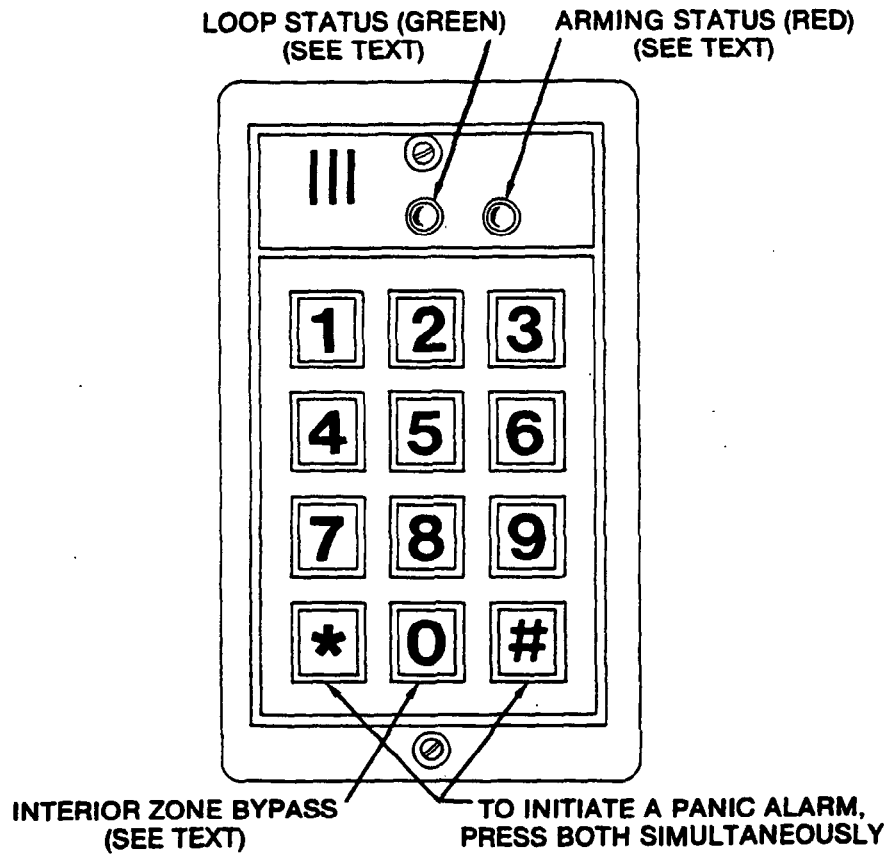
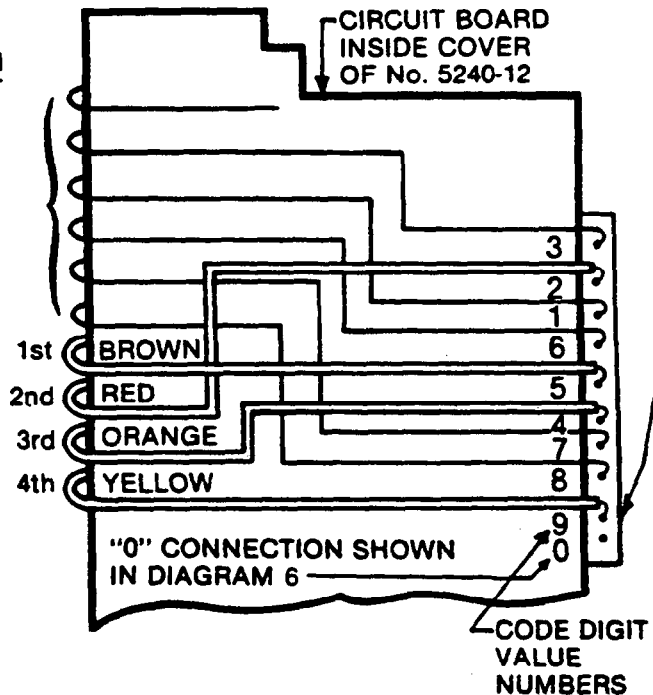

Diagram 4: No. 5240-12 REMOTE DIGITAL KEYPAD STATION

6 WHITE (SOLID) WIRES.
 INSERT ONE INTO EACH
 CONNECTOR HOLE NOT
 USED FOR CODE DIGIT
 SELECTION WIRES
 (OMIT "0")
 NOTE: One WH wire
 is not used (tape end).

CODE DIGIT
 SELECTION WIRES
 (SOLID CONDUCTORS)

CODE 5-2-4-9 HAS
 BEEN PROGRAMMED
 IN EXAMPLE SHOWN
 HERE



10 PIN CONNECTOR
 (BELOW EDGE OF
 PC BOARD)
 IMPORTANT: Bend each
 wire's end as shown
 below before inserting
 in connector.

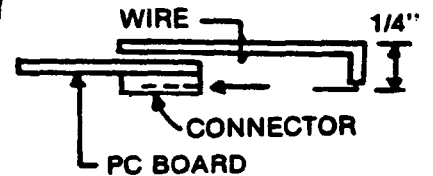

Diagram 5: ARM/DISARM CODE PROGRAMMING OF No. 5240-12

USE U.L. LISTED LIMITED ENERGY CABLE FOR ALL CONNECTIONS.

FIRE PROTECTION MUST FOLLOW NFPA STANDARD No. 74 (National Fire Protection Assoc., Batterymarch Park, Quincy, MA 02269).

JUMPER	FUNCTION	IF INTACT	IF CUT
YELLOW	PERIMETER ZONE RESPONSE	NORMAL	FAST
RED	INTERIOR ZONE RESPONSE	NORMAL	FAST
BLUE	PANIC ALARM	AUDIBLE	SILENT
WHITE	ENTRY/EXIT DELAY	45 SECS	30 SECS
GREEN	HORN DURATION	12 MIN (8 MIN IF WHITE CUT)	24 MIN (16 MIN IF WHITE ALSO CUT)

CONNECTOR (FOR No. 5240-12P IN No. 4021-12)
GREEN CABLE WIRE MUST BE ON RIGHT.

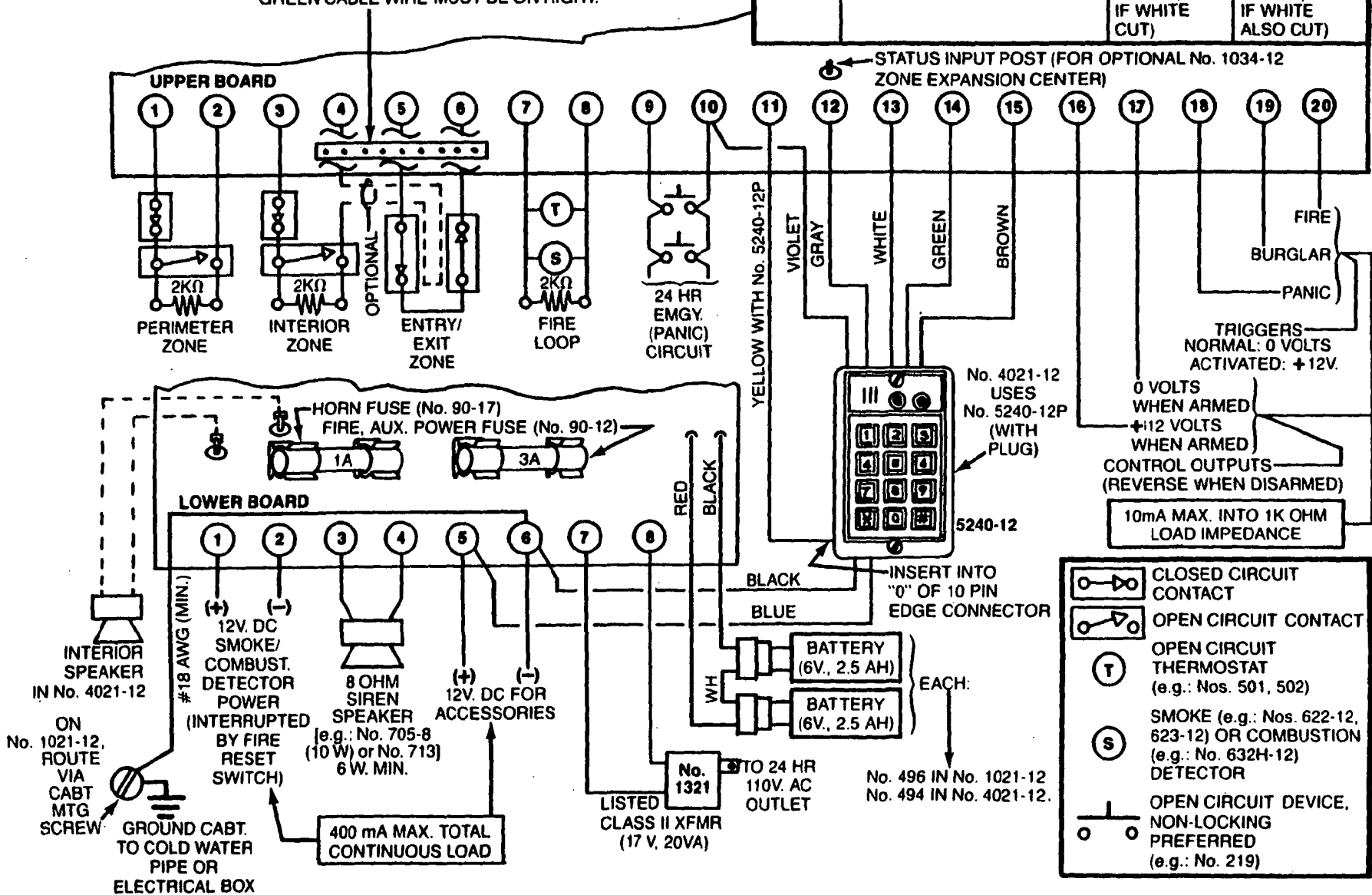

Diagram 6: SYSTEM FIELD CONNECTIONS

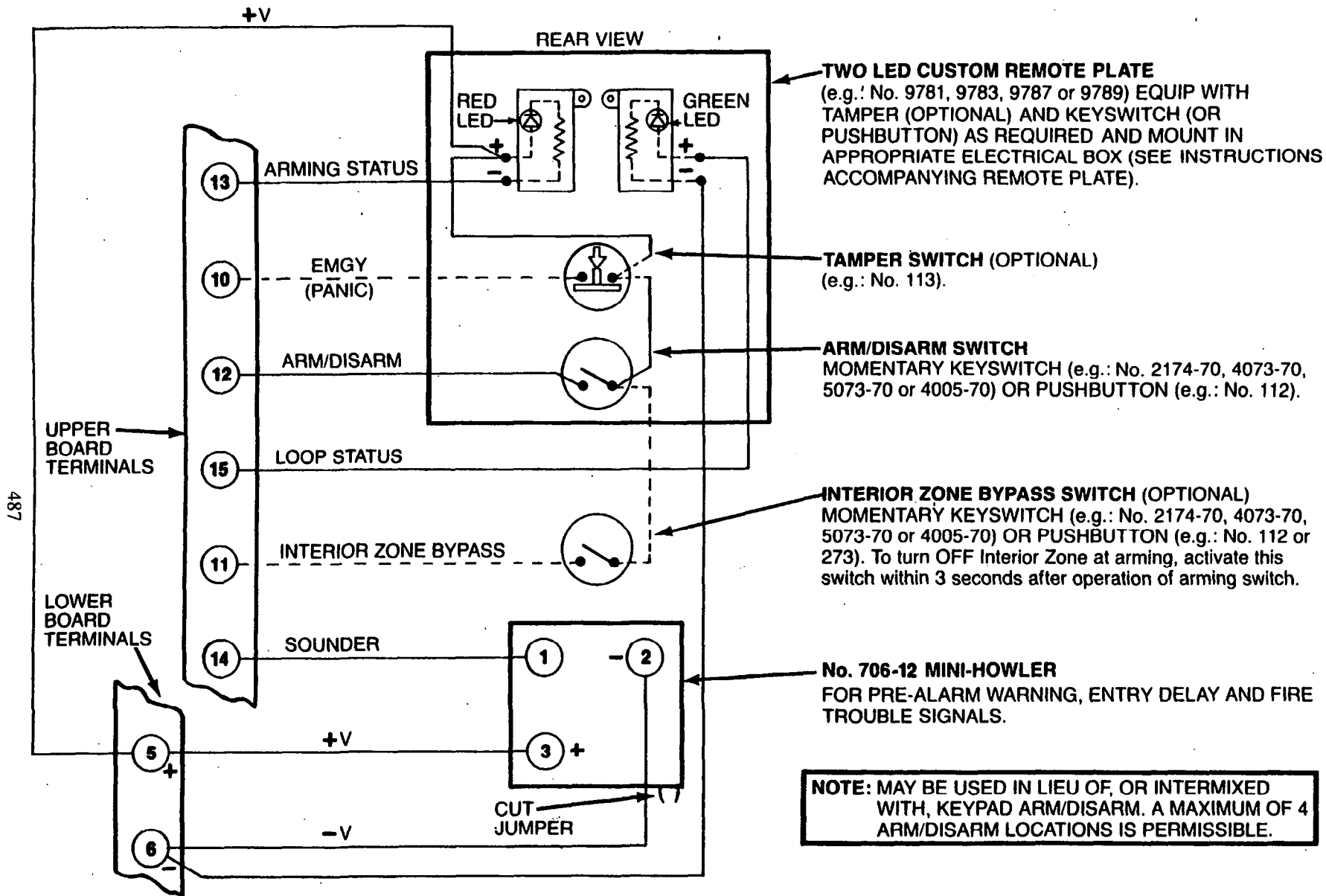

Diagram 7: ALTERNATIVE ARM/DISARM CONFIGURATION WITH KEYSWITCH(ES)/PUSHBUTTON(S)

ADDENDUM TO: **INSTALLATION INSTRUCTIONS**
for Nos. 1021, 4021, 1021-12 and 4021-12
RESIDENTIAL ALARM SYSTEMS

RE: **ARMING PRECAUTION**

The following paragraph should be added to Step 4 of the "To Arm Burglary System" section on Page 8 of the accompanying installation instructions. In addition, it should be called to the attention of the subscriber when the system is turned over to him by the installer.

Arming Precaution: After entering the arming code, wait 3 seconds (whether turning OFF the Interior Zone or not) before opening the entry/exit door to depart. To do so sooner could cause the system to fail to arm (which would be indicated by an audible buzzer and extinguished RED Arming Status LED).

ADEMCO

P8580XX 11/82

ALARM DEVICE MANUFACTURING CO.

A DIVISION OF PITTMAY CORPORATION

165 Eileen Way, Syosset, New York 11791

Copyright © 1982 PITTMAY CORPORATION

ADDENDUM TO: **INSTALLATION INSTRUCTIONS FOR NOS. 1021, 4021,**
1021-12 AND 4021-12 RESIDENTIAL ALARM SYSTEMS

RE: **GROUNDING**

The subject Residential Alarm Processing Centers have been improved to increase their ability to resist disturbances caused by lightning and static electricity. A green flying lead has been added to each control's upper board.

Please substitute the following information for the grounding methods shown on pages 6 and 14 of the accompanying installation instructions and on the summary of connections diagram inside the control:

Ground: Ground upper board GREEN flying lead to a cold water or electrical box earth ground. Use #18 AWG (minimum) stranded wire. On Nos. 1021 and 1021-12 Controls, route via one of the cabinet's mounting screws.

ADEMCO

P8580YY. 4/83

ALARM DEVICE MANUFACTURING CO.

A DIVISION OF PITTMAY CORPORATION

165 Eileen Way, Syosset, New York 11791

Copyright © 1983 PITTMAY CORPORATION

488
480