

7835C

Cellular Control Channel Transceiver

Installation and Setup Guide

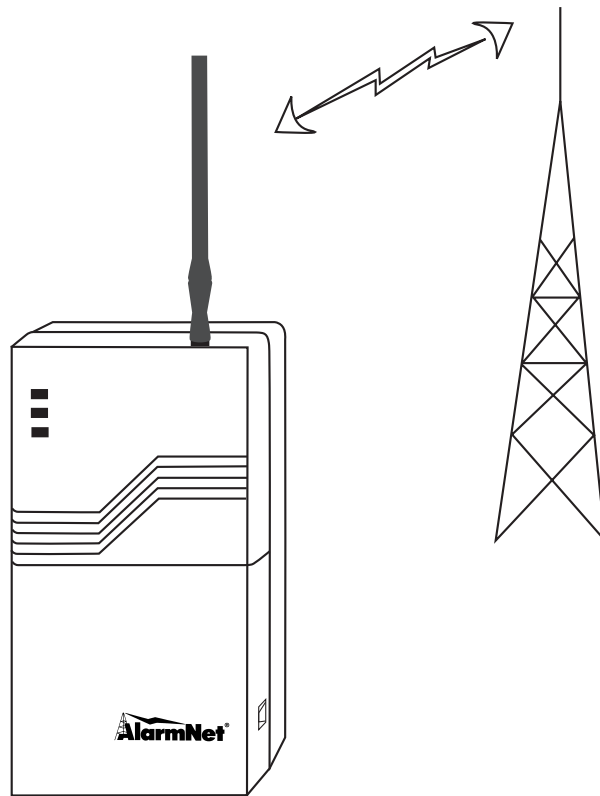

Table of Contents

List of Terms	2
Section 1. General Information	3
Introduction	3
System Features	3
Section 2. Quick Start/Programming Guide	4
Section 3. Installation and Setup	6
Removing the Lower Cover	6
Initial Power-Up Sequence	7
Selecting a Radio Installation Site	8
Testing the Installation.....	9
Section 4. Programming the 7835C.....	10
Using a 7720P Programming Tool.....	10
Subscriber Information.....	11
Pulse/Delay Zone Selection	12
Inverted Zone Selection	13
Restoral Reporting Zone Selection	13
Open/Close, Telco, Tamper Zone Selection	14
System Options	14
Redundant Central Station Reporting	15
Exiting Program Mode, Setting Defaults and Assigning Passwords.....	16
Section 5. Registration	17
Section 6. Mounting and Wiring	19
Section 7. Operation Overview	24
Section 8. Keyboard Commands	26
Section 9. Troubleshooting.....	28
Specifications	30
Summary of Connections Diagram	31

List of Terms

AMPS:	Acronym for Advanced Mobile Phone System, which is the existing analog mobile phone system used for cellular communication in North America.
A Side / B-Side:	The FCC has divided the spectrum allocated to cellular communication between two carriers in each geographic location: A and B. The “B” side is operated by the local telephone company (known a wireline), while the “A” side is run by a competitor (known as non-wireline).
Cell:	The equipment, including antennas, RF transmitters, RF receivers, that is used to establish and route communications between a mobile cellular radio and its intended end point.
Control Channel:	Any one of several dedicated RF channels that are used by a cellular radio to register its MIN with a local cell and to periodically check in with that cell. The control channel is also used by the radio to “dial” a phone number through the cell. Additionally, control channels are used by the cell to “ring” a mobile cellular radio.
MIN:	Acronym for Mobile Identification Number, which is a cellular radio’s unique, 10-digit “phone number.”
SS7:	Acronym for Signaling System Seven, which is the network that is used by all telephone companies for dialing and establishing all cellular and land-line phone calls.
Voice Channel:	Any one of many dedicated RF channels used for transmitting and receiving audio data between a mobile phone and a cell. (Not used with the 7835C.)

Section 1: General Information

Introduction

The 7835C is the subscriber end of the AlarmNet C reporting system. It is comparable to a digital communicator, but instead of transmitting signals over the telephone lines, it transmits radio signals to the central monitoring station using the control channel of the AMPS cellular phone network. This allows faster and more secure reporting and greater coverage.

The 7835C is compatible with existing installations using ADEMCO equipment or other control panels. It can be used in conjunction with digital communicators on the same system to provide redundant reporting.

The 7835C Transceiver uses the control channel of the Advanced Mobile Phone System (AMPS) cellular network to report subscriber alarms and system status messages. It operates on either the "A" or "B" side of the cellular network without using a voice channel. Because alarms are transmitted only on the control channel, a true "phone call" is never placed. This eliminates delays due to busy or saturated cells where no voice channels are available.

The 7835C is compliant with the MicroBurst standard for packet-based control channel cellular communication. Alarm and status packets are transmitted from the subscriber to a local cell where they are identified and then routed using SS7 to the AlarmNet Control Center. The AlarmNet Control Center then logs the alarm and routes it via RF to the appropriate AlarmNet-A or AlarmNet-M equipped central station.

System Features

Hardware Features

- Up to 6 input zones (when ECP is not used) that can be triggered by either applying or removing a voltage.
- Zones 1 and 2 are configurable to trigger on the application of a voltage or ground.
- Zones 5 and 6 are configurable as voltage-tripped zones or as ECP IN / ECP OUT, respectively (the installer must choose either zone inputs or ECP communication, not both).
- Radio fault relay Form A contacts, programmable.
- Auxiliary, general purpose relay, Form A contacts, controllable across the radio link.
- Trigger voltage for use with dry contact relays.

LED Indications

- Received Signal Strength Indication (RSSI), displayed on a 5-position bar graph.
- Three radio status LEDs to indicate message status and radio status.

Antenna

- ADEMCO cellular antenna included (part number K3209).

Power

- Wall-mounted 16.5VAC / 40VA transformer ADEMCO PN: 1361.
- Optional battery backup adds up to 4 hours of additional system life during AC loss. ADEMCO PN: 7720BT

Programmable Features

- | | |
|--|--|
| • Subscriber, city and central station ID | • Tamper zone |
| • Carrier selection | • Old alarm time reporting period |
| • Supervision messaging period | • AC loss reporting |
| • Time zone | • Battery backup with optional battery |
| • Steady state or pulsed zones with delays | • Radio fault relay |
| • Inverted zone trigger levels | • Radio fault time |
| • Zone restoration messaging | • Secondary CS reporting |
| • Open/Close reporting | • Password assignment |
| • Telco fault zone | |

Section 2: Quick Start/Programming Guide

1. Unpack and initialize the radio.

- Unpack the 7835C and install the antenna.
- Remove the unit's lower cover (refer to *Removing the Lower Cover* section).
- Connect a fully charged battery (Ademco 7720BT) or a 40VA transformer (Ademco 1361).
- Monitor the initial power-up LED sequence (refer to the Initial Power-Up Sequence section). This can take several minutes.

2. Find coverage and select a site.

- Verify MicroBurst coverage using the radio status LEDs as shown below, or use the "B" command on the 7720P Programming Tool.
- Select an installation site by observing the signal strength (RSSI) bar graph or use the "B" command on the 7720P Programming Tool (refer to the *Selecting a Radio Installation Site* section for detailed procedure) :

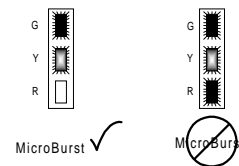

3. Test the site.

- Test the RF link between the 7835C and the local cell with a single click test message (refer to the *Testing* section for details).
- Test communication with the AlarmNet C network by double clicking the tamper/test switch and receiving message validation. If desired, you can cancel validation by clicking the tamper switch once.

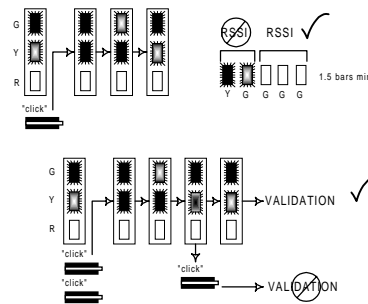

4. Program the radio.

- Connect the 7720P Programming Tool, reset the radio by cycling the power off then on, then press [Enter] during the initial power-up sequence to enter Programming mode.
- Program the 7835C as described in the *Programming* section. Refer to the programming defaults on the next page.

5. Register the radio.

- Register the 7835C with AlarmNet by triple clicking the tamper switch and observing the LED displays as shown below, or by pressing the [↑] key on the 7720P.

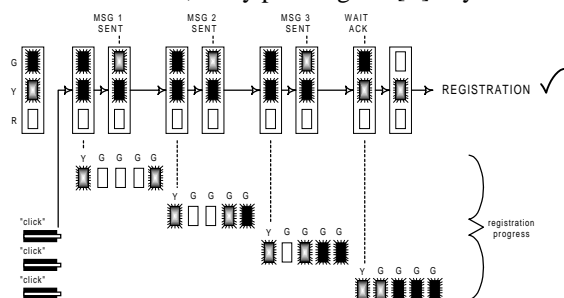

6. Complete the installation.

- Mount the radio (refer to the *Mounting* section).
- Wire to the Control (refer to the *Wiring* section) and test all signals.
- Test the installation (refer to the *Testing* section)

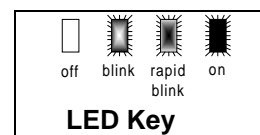

Quick Start/Programming Guide

7835C Programming Defaults

* Programming options 1, 2 and 3 must be programmed to complete Quick Start.

Programming Option	Default Value	Actual Entry	7720P Keyboard Commands
ID Number *	xxxx		A Software revision
City Number *	xx		B Radio and connectivity display (network OK, no service, no contact, signal strength, A or B carrier, MIN)
CS ID *	xx		C Network time display
Supervision	24 hours		D Battery test (starts 10 minute battery test)
Time Zone	Eastern		E Network system display (channel, local carrier, SID)
Carrier Select	Auto		F Carrier display (A or B carrier, MicroBurst found, preferred side indication)
Pulse Z1 (Y/N)	N		S Status display
Z1 Delay (00-127)	3		T Test signal
Pulse Z2 (Y/N)	N		X Reset
Z2 Delay (00-127)	3		
Pulse Z3 (Y/N)	Y		
Z3 Pulse Count	3		
Pulse Z4 (Y/N)	N		
Z4 Delay (00-127)	3		
Pulse Z5 (Y/N)	N		
Z5 Delay (00-127)	3		
Pulse Z6 (Y/N)	N		
Z6Delay (00-127)	3		
Invert Z1 (Y/N)	N		
Invert Z2 (Y/N)	N		
Invert Z3 (Y/N)	N		
Invert Z4 (Y/N)	N		
Invert Z5 (Y/N)	N		
Invert Z6 (Y/N)	N		
Restore Z1 (Y/N)	Y		
Restore Z2 (Y/N)	Y		
Restore Z3 (Y/N)	Y		
Restore Z4 (Y/N)	Y		
Restore Z5 (Y/N)	Y		
Restore Z6 (Y/N)	Y		
Open/Close Zone	0		
Telco Channel	0		
Tamper Zone	8		
Old Alarm Time	10 minutes		
AC Loss Report	Y		
Battery Present (Y/N)	Y		
Fault Relay On (Y/N)	N		
Fault Time (minutes)	5		
2 nd CS Report (Y/N)	N		
Review?	N		
Enter Password? (Y/N)	N		

Section 3: Installation and Setup

Removing the Lower Cover

During normal operation, the lower cover of the 7835C should remain in place.

To remove the cover, gently press in on either of the two locking tabs and lift the cover.

Removing the cover will trigger the following two events:

1. A tamper zone alarm will be transmitted.
2. The RSSI bar graph, which is intended to be used as an installation tool and troubleshooting aid, will light.

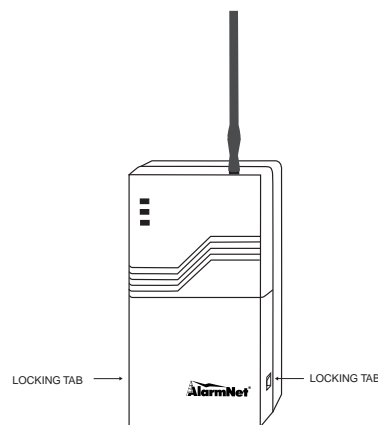

Do not attempt to remove the upper cover. There are no user serviceable components beneath this cover.

Refer to the following diagram to identify the components of the 7835C.

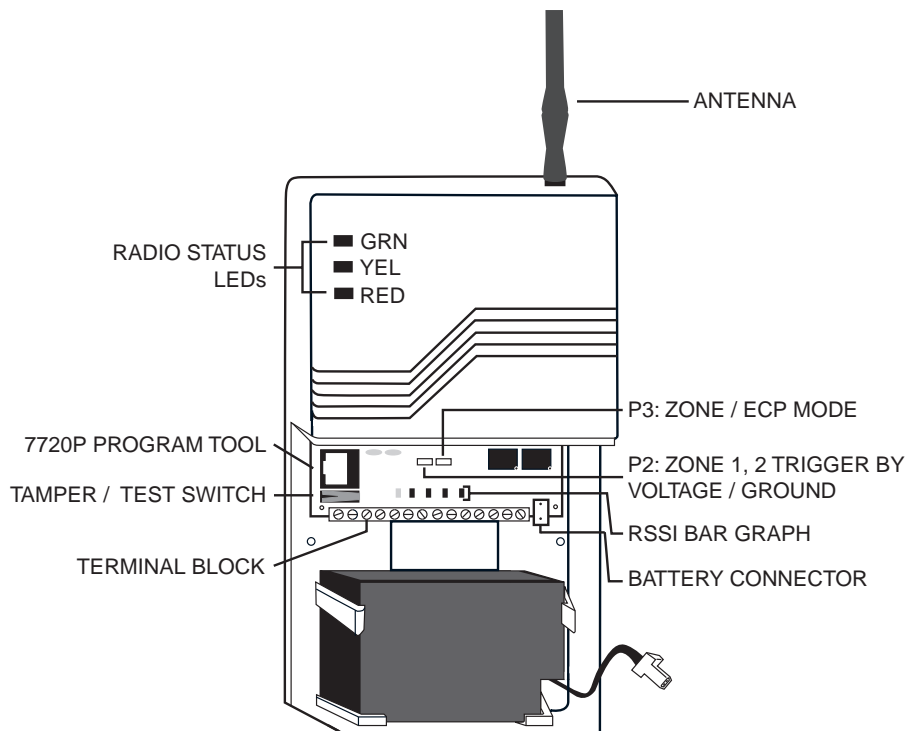

Figure 1. 7835C with Cover Removed for Component Identification

7835C Initial Power-Up Sequence

Before connecting power, check that the following have been completed:

- 16.5VAC / 40VA transformer connected to terminal block positions 1 & 2
- P2 in the correct position for zone 1 & 2 trigger levels (zone mode only)
- P3 in the correct position for zone or ECP operation
- Antenna installed

Apply power by plugging in the 16.5VAC / 40VA transformer. If using the optional battery, plug it into the battery jack on the 7835C PC board. Initially, all 7835C programming options are set to the factory default settings.

Upon applying power, the 7835C enters the power-on reset mode, indicated by all 8 LEDs being solidly lit for approximately 5 seconds followed by the RSSI bar graph green LEDs lighting in a “chaser” sequence from left to right. After this power-up sequence, the Radio Status LEDs display solid green, solid red, and blinking yellow.

This indicates the 7835C is functioning but not yet initialized. The 7835C then enters an initialization sequence. During this process, the 7835C is verifying its Mobile Identification Number (MIN) and checking for MicroBurst service on both the “A” and “B” side carriers. This activity is displayed on the RSSI bar graph as follows: The yellow LED will remain unlit and the green LED at the extreme right of the display will begin to blink. This green LED then lights solid (after a short period of time), and the next green LED to the left begins to blink. When this LED lights solid, the next green LED begins to blink, and so on, until all 4 green LEDs are lit solid. This countdown event may take up to 3 minutes to complete.

Once this sequence has been completed, the RSSI display begins to function as a signal strength indicator as described in *Selecting a Radio Installation Site* section. The radio is now in normal, unprogrammed and unregistered operation. If radio setup and self-test fails, LED 5 will blink continuously and no further progress will be made. If MicroBurst coverage is not found on either the A or the B side, the 7835C will repeat steps 2 and 3. These steps will be repeated until MicroBurst is found.

Table 1. 7835C Initial Power-Up Bar Graph and Radio Status LED Sequence

Active Function	Bar Graph Display	Radio Status Display
1) LED 5 blinking: 7835C performing radio setup and self-test. Time to complete: less than 1 minute.	<p>1 2 3 4 5 Y G G G G</p>	<p>G Green on: un-registered</p> <p>Y Yellow blinking: waiting</p> <p>R Red on: no MicroBurst coverage</p>
2) LED 4 blinking: 7835C searching for MicroBurst coverage from the B-side carrier. Time to complete: 1 – 3 minutes	<p>5 on: radio set-up ok.</p>	<p>G Green on: un-registered radio Green blinking: service request message successful, B-side Green off: previously registered radio</p> <p>Y Yellow on: request for service message pending, B-side Yellow blinking: B-side (once per second)</p> <p>R Red on: MicroBurst coverage not yet found, B-side Red blinking: service request message un-successful, B-side Red off: MicroBurst coverage found, B-side</p>
3) LED 3 blinking: 7835C searching for MicroBurst coverage from the A-side carrier. Time to complete: 1 – 3 minutes	<p>4 on: B-side MicroBurst OK or 4 off: B-side MicroBurst fail.</p>	<p>G Green on: un-registered radio Green blinking: service request successful, A-side Green off: previously registered radio</p> <p>Y Yellow on: request for service pending, A-side Yellow blinking: A-side (twice per second)</p> <p>R Red on: MicroBurst coverage not yet found, A-side Red blinking: service request message un-successful, A-side Red off: MicroBurst coverage found, A-side</p>
4) LED 2 on: 7835C initial powerup complete. Time to complete: 10 seconds	<p>3 on: A-side MicroBurst OK or 3 off: A-side MicroBurst fail.</p>	<p>G Green on: un-registered radio Green off: previously registered radio</p> <p>Y Yellow blinking: A-side or B-side blink indication</p> <p>R Red on: no MicroBurst coverage Red off: MicroBurst coverage, carrier indicated by Yellow LED</p>
Initial power-up fail Display time: 30 seconds	<p>All LEDs blinking</p>	<p>LED Key:</p>

Selecting a Radio Installation Site

The 7835C is designed to be mounted on a vertical surface (wall), with the included antenna pointing up. When selecting mounting a site, maintain distances from various types of electrical equipment as listed in Table 2. Additionally, observe the maximum wire run lengths (see Table 4).



The 7835C is intended for indoor installation only. Mounting outdoors will cause system failure and may present a shock hazard.

1. Remove the cover and install a fully charged battery. If a fully charged battery is not available, you can connect a 16.5VAC / 40VA transformer.



During battery operation, removal of the lower cover will significantly reduce the life of the charge on the battery. To get the maximum backup battery life in the event of an AC loss, the lower cover must be replaced when the installation is complete. (Note that the signal strength bar graph located below this cover is only needed during installation.)

2. Select a likely location by monitoring the signal strength bar graph. Refer to the *Using an Unregistered 7835C as an Installation Tool* paragraph below. A strong signal lights more LEDs than a weak signal. Since the bar graph is not updated instantly, wait a few moments before moving to another location.
3. Find a location where the signal strength level is at least 1-½ bars or -104dBm as measured with the 7720P. The 7835C can function properly with the signal strength level as low as one-half bar (yellow blinking), but this may be an indication of marginal coverage.

Notes:

1. Optimum RF performance can usually be found at the highest point within a building, with the fewest number of walls between the radio and the outside of the premises.
2. Avoid mounting the antenna near other electronic devices. Table 2 provides minimum distances. Highest RF energy is in the direct, horizontal line of the antenna. Therefore, vertical separation (moving electronic devices either higher or lower on the wall) provides a higher level of isolation from the radio.

Equipment	Distance
Short-range receiver	20 ft.
PIR	10 ft.
Control panel	25 ft.
FM radio or TV ant.	25 ft.
Other devices	10 ft. minimum

Using an Unregistered 7835C as an Installation Tool

An unregistered 7835C will automatically default to the signal strength display once the initial power-on sequence is complete.

Use the guide on the right when selecting an installation site. The bar graph is updated after each test message.

Select an installation site where the RSSI is between 2 – 5. bars.

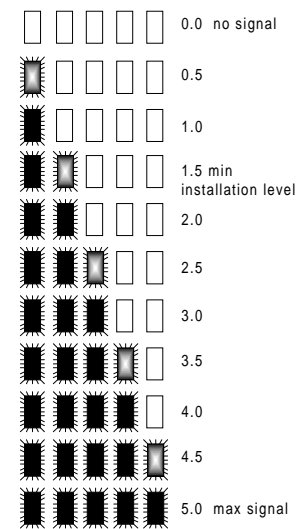
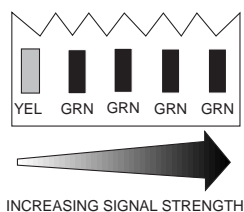

Signal Strength Bar Graph Displays

Testing the Installation

Using an Unregistered 7835C to Test the Installation

An unregistered 7835C can send two types of test messages, unvalidated and validated, by clicking the unit's tamper switch as described below. Both types of messages can be cancelled by clicking the tamper switch once. Using the unvalidated test message provides faster feedback to the bar graph and tests the radio's ability to communicate with the cell. It reduces the volume of message traffic and speeds the installation time.

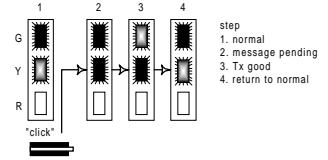
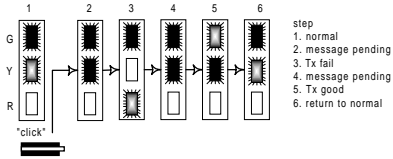
<p>SINGLE click the tamper switch to send a test message to the local cell. The RSSI bar graph displays how well the 7835C is receiving this cell. Read the RSSI display from left to right: If the yellow and the next two green LEDs are illuminated, the display is read as “three bars.” If the yellow and the next two green LEDs are lit solid with the following green LED flashing, the display is read as “three and a half bars.” This is a stronger received signal than the previous example. Refer to the Full Scale RSSI Display diagram on the previous page.</p>	<p>Radio status LEDs for a good test message transmission to local cell:</p>  <p>Radio status LEDs for a failed test message transmission and a good retransmission to local cell:</p> 
---	---

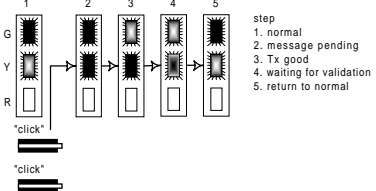
<p>DOUBLE click the tamper switch to send a test message to AlarmNet with a validation request. The yellow radio status LED blinks rapidly while waiting for validation. Validation is a low priority receipt from AlarmNet to the 7835C and may take several minutes to receive. If a message is not validated by AlarmNet within 90 seconds, the 7835C will retransmit the test message and wait for validation.</p>	<p>Radio status LEDs for a good test message transmission to AlarmNet and validation:</p> 
---	---

NOTE: When a good test message is sent from the 7835C, it can be assumed with a high degree certainty that it reached AlarmNet without waiting for validation

To cancel validation, SINGLE click the tamper switch while yellow led is blinking rapidly.

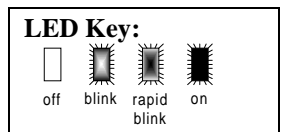

Section 4: Programming the 7835C

Using a 7720P Programming Tool

The 7720P Programming Tool is powered by the 7835C via the Programming Jack. The 7835C will automatically sense the presence of the 7720P when it is plugged in.

Each key of the 7720P has two possible functions: a normal function and a SHIFT function. To perform a normal key function, simply press the desired key. To perform a SHIFT key function, press the SHIFT key, then press desired function key.

Table 3. 7720P Normal & Shift Key (shift LED lit) Functions

Key	Normal Key Function	SHIFT Key Function
BS/ESC	[BS]: Press to delete entry	[ESC]: Press to quit program mode; also can reset EEPROM defaults*
↓/↑	[↓]: Scroll down programming	[↑]: Scroll up programming
N/Y	[N]: Press for "NO" answer	[Y]: Press SHIFT-Y for "YES" answer
SHIFT	Press before pressing a SHIFT key function. Will light SHIFT LED. LED goes out once a key is pressed. Press again for each SHIFT function desired.	
1/A	[1]: For entering the number 1	[A]: For entering letter A
2/B	[2]: For entering the number 2	[B]: For entering letter B
3/C	[3]: For entering the number 3	[C]: For entering letter C
4/D	[4]: For entering the number 4	[D]: For entering letter D
5/E	[5]: For entering the number 5	[E]: For entering letter E
6/F	[6]: For entering the number 6	[F]: For entering letter F
7/S	[7]: For entering the number 7	[S]: For entering letter S
8/T	[8]: For entering the number 8	[T]: For entering letter T
9/X	[9]: For entering the number 9	[X]: For entering letter X
/SPACE	[]: For scrolling option list	[SPACE]: For scrolling option list
0	[0]: For entering the number 0	No SHIFT function
#/ENTER	[#/ENTER]: Press to accept entries	No SHIFT function

* Active only when the "REVIEW?" prompt is displayed.

After connecting the 7720P cable, power up the 7835C. The following will be displayed:

7835C x.xx
(c) Pittway 1998

x.xx = current software revision level

At this prompt, you may proceed with programming the 7835C. Programming is accomplished by answering displayed questions. Most questions require only a [Y]es or [N]o response, while others require a numerical response (ID numbers, etc.). Press ENTER to accept each response and proceed to the next question. A "?" indicates an invalid entry. The current value is displayed on the second line in parentheses (). To accept the current entry, simply press the ENTER key. If the current value is an invalid entry, pressing the enter key will cause the display to repeat the unanswered question; the next question will not be displayed until a valid answer is entered. Use the UP/DOWN arrow keys to scroll through the programming questions without changing any values. The ESC key will bring the list of questions to the end only if ALL questions have valid answers (either by default or entry).

Enter programming mode by pressing [ENTER] during the initial power-up period after the chaser sequence (while radio status LEDs are flashing consecutively or in unison).

The 7835C reads its EEROM to determine its preprogrammed parameters. A CRC of the EEROM locations is also read. If the computed CRC does not match the one read from EEROM, or if the programming parameters are invalid, the 7720P LCD displays "NO PROG." Otherwise, press ENTER while the three LEDs flash in unison to begin programming.

Password Protection

If you are NOT programming the radio through an ECP capable control panel (e.g., VISTA-128FB), the programming menu can be password protected

Once a password is assigned, the following prompt appears upon entering programming mode:

ENTER PASSWORD:

See "Exiting Program Mode" paragraph later in this section for assigning and changing passwords.

Subscriber Information

- Question 1*. Press "Y" to enable ECP communication for alarm input (check that jumper P3 is to right). Press "N" to enable voltage triggers for alarm input.
* This question will NOT appear if you are programming via the control panel, since ECP mode is automatically required; Question 2 will be the first programming option.
- Question 2. Enter the 4-digit customer account number, 0001-9999.
- Question 3. Enter the 2-digit primary city code, 01-99 (decimal).
- Question 4. Enter the primary central station's system ID number, 01-FE.
- Question 5. This selection sets the supervision timing for the 7835C. Currently, the only supervision timing available is 24-Hr. AlarmNet service. In this mode, the 7835C sends a supervision message once in a 24-hour period. AlarmNet transmits a communications failure alarm to the central station if the supervision message is not heard within the 24-hour period.
- Question 6. Use the [*] key to select the time zone in which the 7835C is being installed: Eastern, Central, Mountain, Pacific, or Atlantic.
- Question 7. Use the [*] key to choose the method by which the 7835C will select its cellular carrier: "A" or "B" side.
Auto: 7835C selects the carrier to which it will connect. In this mode, the 7835C will automatically change its carrier side if coverage becomes degraded.
NOTE: If the 7835C had been operating and completed its initialization sequence with this option set to "auto," one of the following prompts will appear:
Auto B then A: shows that the B-side carrier was initially selected.
Auto A then B: shows that the A-side carrier was initially selected.
These prompts are displays only, not programming choices, and the prompt will disappear if the [*] key is pressed.
A then B: 7835C prefers connecting to the "A" side carrier rather than the "B" side carrier. If coverage is lost on the A side, the radio will switch to the "B" side carrier.
B then A: 7835C prefers connecting to the "B" side carrier rather than the "A" side carrier. If coverage is lost on the B side, the radio will switch to the "A" side carrier.
A Only: 7835C searches for coverage on the "A" side only. Fixed carrier operation.
B Only: 7835C searches for coverage on the "B" side only. Fixed carrier operation.
- Question 8. **Skip this question if using zones (if you answered "N" to Question 1) and go to Question 8a.**
If using ECP mode (you answered "Y" to Question 1), enter the ECP device address of the radio. For VIA 30+, VISTA-10, VISTA-20, and VISTA-128FB this must be address 3. For other control panels, see the control panel's Installation Instructions. Skip to Question 30.

Pulse/Delay Zone Selection

By configuring a zone as a pulsed zone, it is possible to use the output of a panel bell/siren driver to activate the radio directly when the signal from this driver is a pulsed output for fire and a continuous output for burglary. To implement a fire/burglary detection at the radio, connect the driver output directly to 2 zones on the 7835C. Program the fire zone as a pulsed zone and the burglary zone as a delayed zone (this is to prevent this zone from reporting an alarm when the pulsed signals are detected). The number of pulses and the length of delay will depend on the particular panel or siren driver being used, and is therefore a programmable feature.



Zones designated as open/close or telco zones cannot be programmed for pulse. If this occurs, the pulse detection on the zone is automatically disabled.

UL

The control unit total delay shall not exceed 14 seconds in UL Listed applications if "yes"; 0.30 seconds if "no."

- | | | |
|--------------|--------------------------------|---|
| Question 9a | Pulse Z1 (Y/N) | Press "Y" if zone 1 is connected to a pulsed bell output. Question 9c will appear. If you pressed "N", the following appears. |
| Question 9b | Z1 Delay
(00-127) | Enter the reporting delay from 1-127 seconds for zone 1.
Enter "00" for no reporting delay. |
| Question 9c | Pulse Cnt? (Y/N)
(03 - 254) | If you answered "Y" to "Pulse Z1," the next question will be "Pulse Cnt?" Input the number of pulses required to place the zone in alarm. Default is (03). |
| Question 10a | Pulse Z2 (Y/N) | Press "Y" if zone 2 is connected to a pulsed bell output. Question 10c will appear. If you press "N," the following appears. |
| Question 10b | Z2 Delay
(00-127) | Enter the reporting delay from 1-127 seconds for zone 2.
Enter "00" for no reporting delay. |
| Question 10c | Pulse Cnt? (Y/N)
(03 - 254) | If you answered "Y" to "Pulse Z2," the next question will be "Pulse Cnt?" Input the number of pulses required to place the zone in alarm. Default is (03). |
| Question 11a | Pulse Z3 (Y/N) | Press "Y" if zone 3 is connected to a pulsed bell output. Question 11c will appear. If you press "N," the following appears. |
| Question 11b | Z3 Delay
(00-127) | Enter the reporting delay from 1-127 seconds for zone 3.
Enter "00" for no reporting delay. |
| Question 11c | Pulse Cnt? (Y/N)
(03 - 254) | If you answered "Y" to "Pulse Z3," the next question will be "Pulse Cnt?" Input the number of pulses required to place the zone in alarm. Default is (03). |
| Question 12a | Pulse Z4 (Y/N) | Press "Y" if zone 4 is connected to a pulsed bell output. Question 12c will appear. If you press "N," the following appears. |
| Question 12b | Z4 Delay
(00-127) | Enter the reporting delay from 1-127 seconds for zone 4.
Enter "00" for no reporting delay. |
| Question 12c | Pulse Cnt? (Y/N)
(03 - 254) | If you is answered "Y" to "Pulse Z4," the next question will be "Pulse Cnt?" Input the number of pulses required to place the zone in alarm. Default is (03). |
| Question 13a | Pulse Z5(Y/N) | Press "Y" if zone 5 is connected to a pulsed bell output. Question 13c will appear. If you press "N," the following appears. |
| Question 13b | Z5 Delay
(00-127) | Enter the reporting delay from 1-127 seconds for zone 5.
Enter "00" for no reporting delay. |

Question 13c If you answered “Y” to “Pulse Z5,” the next question will be “Pulse Cnt?” Input the number of pulses required to place the zone in alarm. Default is (03).

Question 14a Press “Y” if zone 6 is connected to a pulsed bell output. Question 14c will appear. If you press “N,” the following appears.

Question 14b Enter the reporting delay from 1-127 seconds for zone 6. Enter “00” for no reporting delay.

Question 14c If you answered “Y” to “Pulse Z6,” the next question will be Pulse Cnt? Input the number of pulses required to place the zone in alarm. Default is (03).

Inverted Zone Selection

You can program zones 1-6 for inverted input signals.

Question 15 Press “Y” to invert the input signal for zone 1. Press “N” for normal input signal.

Question 16 Press “Y” to invert the input signal for zone 2. Press “N” for normal input signal.

Question 17 Press “Y” to invert the input signal for zone 3. Press “N” for normal input signal.

Question 18 Press “Y” to invert the input signal for zone 4. Press “N” for normal input signal.

Question 19 Press “Y” to invert the input signal for zone 5. Press “N” for normal input signal.

Question 20 Press “Y” to invert the input signal for zone 6. Press “N” for normal input signal.

Restoral Reporting Zone Selection

Restoral reporting can be enabled or disabled. If you have programmed any of the zones for pulse operation, then, following the restoral question, the 7720P will display "REST ON CHG (Y/N)". This feature is used for zones connected to the bell output of a panel, and when enabled (by pressing “Y”) will report the zone in restoral when the pulse train stops and a steady-state level, either high or low, is left on the zone input or when the steady-state level starts pulsing. If you do not enable this feature (by pressing “N”), the zone will only restore on a steady-state low logic level.

Question 21 Press “Y” to enable restoral reporting for zone 1. Press “N” to disable restoral reporting

Question 21a Press “Y” if restore is to be sent when the type of signal changes, i.e., when pulsing state changes to a steady-state level (high or low) or when a steady state changes to a pulsing state. Restore normally occurs when the opposite steady state occurs, e.g., when a steady-state high goes low.

Question 22 Press “Y” to enable restoral reporting for zone 2. Press “N” to disable restoral reporting.

Question 22a Press “Y” if restore is to be sent when the type of signal changes, i.e., when pulsing state changes to a steady-state level (high or low) or when a steady state changes to a pulsing state. Restore normally occurs when the opposite steady state occurs, e.g., when a steady-state high goes low.

- Question 23 Press "Y" to enable restoral reporting for zone 3. Press "N" to disable restoral reporting.
- Question 23a Press "Y" if restore is to be sent when the type of signal changes, i.e., when pulsing state changes to a steady-state level (high or low) or when a steady state changes to a pulsing state. Restore normally occurs when the opposite steady state occurs, e.g., when a steady-state high goes low.
- Question 24 Press "Y" to enable restoral reporting for zone 4. Press "N" to disable restoral reporting.
- Question 24a Press "Y" if restore is to be sent when the type of signal changes, i.e., when pulsing state changes to a steady-state level (high or low) or when a steady state changes to a pulsing state. Restore normally occurs when the opposite steady-state occurs, e.g., when a steady state high goes low.
- Question 25 Press "Y" to enable restoral reporting for zone 5. Press "N" to disable restoral reporting.
- Question 25a Press "Y" if restore is to be sent when the type of signal changes, i.e., when pulsing state changes to a steady-state level (high or low) or when a steady state changes to a pulsing state. Restore normally occurs when the opposite steady state occurs, e.g., when a steady-state high goes low.
- Question 26 Press "Y" to enable restoral reporting for zone 6. Press "N" to disable restoral reporting.
- Question 26a Press "Y" if restore is to be sent when the type of signal changes, i.e., when pulsing state changes to a steady-state level (high or low) or when a steady-state changes to a pulsing state. Restore normally occurs when the opposite steady state occurs, e.g., when a steady state high goes low.

Open/Close, Telco & Tamper Zone Selection

- Question 27 Enter the open/close reporting zone number, 1-6. A "0" entry will not assign a zone to O/C status monitoring. If the zone selected was programmed to be a pulse zone (see Questions 9-14), the pulse detection on the zone will be automatically disabled. Open/close reporting will require an additional fee.
- Question 28 Enter the physical telco line fault zone, 1-6. A "0" entry disables telco detection. **If this zone is the same as the open/close zone, this selection will automatically be set to "0" and telco detection will be disabled.** If the zone selected was programmed to a pulse zone (see Questions 9-14), the pulse detection on the zone will be automatically disabled.
- Question 29 Enter tamper zone, 7 or 8. A "0" entry disables tamper detection. If tamper is enabled, delayed restores will be automatically generated.

System Options

- Question 30 The old alarm time sets how long and often an undeliverable alarm will be retried for delivery to AlarmNet. If the message is not validated, it will be retried until the old alarm time is reached or the message is validated.
You can change the old alarm time by pressing the space key on the 7720P. If the desired entry has scrolled past, press the back-space key to scroll back through the list. If the desired time is displayed, press the enter key to proceed to the next menu. The choices available are: 10 Min., 15 Min., 30 Min., 1 Hr

- Question 31 If you answered “yes” (Y) to “AC Loss RPT,” the radio will report the loss of AC line voltage within a 10-to 40-minute window after its detection. If this feature is disabled (by pressing “N”), AC loss alarms will be suppressed. NOTE: In either case, if a battery is installed, low-battery messages will be sent as detected.
- Question 32 Press “Y” if optional battery will be used. **Must be “Y” for UL installations (a battery must be installed).**
- Question 33 **If ECP mode is enabled, skip to question 34.** Press “Y” if fail-safe mode is desired. In this mode, the fault relay is normally energized and will de-energize in the event of a radio fault. Note that fail-safe mode draws slightly more standby current.
- Question 34 Enter in minutes 1 - 99 the time delay before the fault relay will change state, after a loss of contact with the network.

If ECP mode is enabled, skip to question 44.

Redundant Central Station Reporting

- Question 35 Press “Y” if redundant reporting to a second central station is desired. Press “N” if not desired (skip to end).
- Question 36 Press “Y” to enable reporting to second central station for zone 1. Enter “N” to disable reporting.
- Question 37 Press “Y” to enable reporting to second central station for zone 2. Enter “N” to disable reporting.
- Question 38 Press “Y” to enable reporting to second central station for zone 3. Enter “N” to disable reporting.
- Question 39 Press “Y” to enable reporting to second central station for zone 4. Enter “N” to disable reporting.
- Question 40 Press “Y” to enable reporting to second central station for zone 5. Enter “N” to disable reporting.
- Question 41 Press “Y” to enable reporting to second central station for zone 6. Enter “N” to disable reporting.
- Question 42 Press “Y” to enable tamper reporting to second central station. Enter “N” to disable reporting.
- Question 43 Press “Y” to enable reporting of system report to second central station. Enter “N” to disable reporting.
- Question 44 Enter the 4-digit customer account number for the second central station, 0001-9999. If you answered “Y” (ECP Mode enabled) to Question 1, you **MUST** enter the second customer account number because the panel may request that a given message is to be sent to the second central station.
- Question 45 Enter the secondary city code 2-digit ID (01-99 decimal). If you answered “Y” (ECP Mode is enabled) to Question 1, you **MUST** enter the secondary city code because the panel may request that a given message is to be sent to the second central station.
- Question 46 Enter the second central station's system ID number, 01-FE. This ID number must be different from the one programmed in Question 4 (the Primary CS ID). If you answered “Y” (ECP Mode is enabled) to Question 1, you **MUST** enter the second central station number because the panel may request that a given message is to be sent to the second central station. This number **DOES NOT** have to be different from the primary number, in this case.

Exiting Program Mode, Setting Defaults & Assigning Passwords

When the last question is answered, the system validates all entries. If no errors are found, the following is displayed:

REVIEW?

To review the programming options (to ensure that the correct responses have been made), press “Y.” The programming questions will be displayed again, starting with Question 1. Use the UP/DOWN arrow keys to scroll through the program fields without changing any of the values. If a value requires change, simply type in the correct value. When the last field is displayed, the “REVIEW?” question again appears.

Setting Factory Defaults: You can reset the programming options globally to their factory default values by pressing ESC at the “REVIEW?” prompt. A confirmation prompt will appear. Press “Y” to reset, or press “N” to return to the “REVIEW?” prompt. If you press “Y,” all programmed values will be reset to their original factory settings.

To exit program mode and assign passwords, press “N” in response to the “REVIEW?” question. If you are NOT programming the radio through a panel and no password has been assigned, the following appears:

ENTER PASSWORD?
[Y/N]

Passwords can be used to split the programming questions into two menus. See the “Password Protection” paragraph earlier in this section. If a password is desired, press “Y”. The following prompts appear. Press “N” if no password is desired.

If a password has already been assigned for the current programming menu, the “ENTER PASSWORD?” prompt is replaced by the following:

CHG PASSWORD?
[Y/N]

Press “Y” or “N,” depending on whether you want to change the password for the current programming menu. If [Y]es, you will be prompted to enter the new password twice (as confirmation). To clear an existing password, answer "Y" to the "CHG PASSWORD" prompt, but press only the ENTER key when prompted for the new password and its confirmation.

ENTER PASSWORD:

Enter the 4-digit password.

VERIFY PASSWORD:

Reenter the 4-digit password as confirmation.

When the password question(s) have been answered, the system exits program mode and returns to normal mode. You can then disconnect the programming tool, or use it to trigger test messages. Refer to *Testing the System* section.

Section 5: Registration

Registering the Radio

Once you have initialized and programmed the 7835C, you must register it with AlarmNet Control. This condition is indicated on the radio status LEDs as: solid green, blinking yellow, and unlit red.

The registration process consists of transmitting 3 messages in succession and receiving a registration validation from AlarmNet Control. It can take several minutes to complete.

Initiate the registration sequence by either clicking the tamper switch 3 times or by pressing shift and the up arrow on the 7720P.

You can monitor the registration process on the RSSI display as follows: yellow LED will be blinking and the green LED at the extreme right of the display will blink. When this green LED lights solid, the next green LED to the left begins to blink. When this LED lights solid, the next green LED begins to blink, and so on, until all 4 green LEDs are lit solid.

Once you have successfully completed the registration, the radio will enter normal operating mode; the green radio status LED extinguishes, the yellow radio status LED continues normal blinking, and the RSSI display indicates received signal strength.

If the registration fails, all 5 RSSI LEDs will blink in unison for 10 seconds. The red radio status LED will blink 5 times, the yellow radio status LED will blink and the green radio status LED will remain lit solid. The 7835C will not attempt another registration sequence automatically. You must initiate a new registration. If repeated registration attempts fail, review and verify the programmed options with a 7720P.

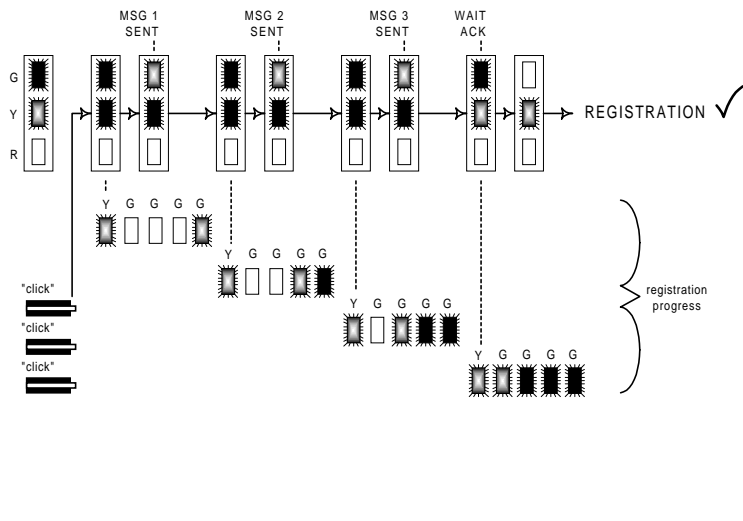

Interactive Registration

The interactive registration feature allows the installer to register the 7835C through a series of keyboard commands on the 7720P installation tool. This method of registration allows the installer to replace an existing 7835C in the event it must be swapped for repair, and allows the installer to monitor the registration process.

Registration
MSG1 Sent

Once the installation is complete the installer should select the [↑] command on the 7720P.

Registration
MSG2 Sent

Three messages are sent, then the unit waits for acknowledgement.

Registration
MSG3 Sent

Registration
Waiting for ACK

Registration
Successful!

If this is a new installation, and the City, CS, and Cust# have been correctly entered, the 7835C will be registered and this message will be displayed. At this point the 7835C is in full service and available for alarm reporting to the central station.

Registration
Timed Out!

If no response to the registration request is received from AlarmNet, this message will be displayed.

Reg Reject
Bad ID! PS

If the City, CS, and Cust# were not correctly entered, this message will be displayed.

If this message is displayed with a "P" primary ID, and or an "S" secondary ID, it indicates that the ID information was either entered in error, or the central station failed to pre-authorize programmed ID numbers with AlarmNet customer service.

Account Exists
PS Sub Y/N

If this is a repair/replacement, or an error was made in programming the 7835C for an existing account, the following prompt will be displayed. "P" and or "S" will be displayed to indicate which ID numbers are causing this condition.

If this is not a replacement/repair, answer "N" to this question and review the CITY, CS, and Cust# programming.

If this is a replacement/repair, answer "Y" and the next prompt will be displayed.

Do You Have A
PIN # Y/N

At this point the installer should have called in for a 4-digit alpha numeric PIN # that must be obtained by having an authorized person call the AlarmNet Technical Assistance Center (TAC). Answering "Y" will continue the registration process. Answering "N" will abort the process. If "Y" was selected then the next prompt will be displayed.

Alarm Will Be
Sent, OK Y/N

If the installer proceeds beyond this point by answering "Y," a correct PIN number must be supplied to complete the registration. Any attempt at registration at this point, whether successful or unsuccessful, will result in a radio substitution alarm being sent to the CS. Answering "Y" allows the installer to continue registration. Answering "N" will abort the registration. If "Y" was chosen the next prompt will be displayed.

Enter PIN#

The installer must enter a 4 digit alpha numeric PIN # that must be obtained by having an authorized person call the AlarmNet TAC. The PIN# should be entered, followed by the enter key.

Registration
Successful!

If the PIN is valid, the new 7835C will register and the old unit will be de-registered. A radio substitution alarm will be sent to the central station by AlarmNet.

Registration
Canceled!

If at any point in the substitution process the installer chooses not to register the 7835C, this is the displayed message.

Substitution
Rejected!

If an invalid PIN was entered this is the display message, and the registration process will be aborted and will need to be started from the beginning. Note that each attempt will cause a radio substitution alarm to be sent to the central station.

Section 6: Mounting and Wiring

Mounting

Install the included “rubber duck” antenna by screwing it onto the connector that extends from the top of the 7835C. The final mounting site should be chosen so that:

- the wire lengths do not exceed the maximum wire lengths as specified in Table 4
- the minimum distance to other electrical devices is maintained
- the minimum signal strength level is observed
- there is access to the 7720P programming port & tamper switch
- all LED displays can be observed
- the antenna is free from any interference

Once the 7835C has been installed, programmed, and tested, anchor the radio permanently to the wall using the screws included with the radio. Use the 3 mounting holes as shown in Figure 2. All 3 mounting holes must be used. It is important to attach the unit securely so that it cannot be removed or accidentally knocked off the wall after installation.

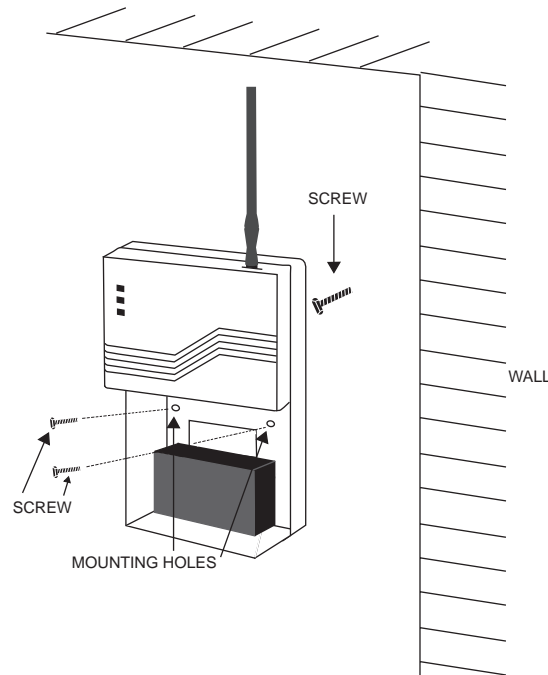

Figure 2. Mounting the 7835C

Wiring the 7835C

Observe the wire length/gauge limitations for all input zone, radio fault and power connections as listed in Table 4.

Gauge	Distance (ft)
18	300
20	200
22	125

Zone Options

For zone operation, set the jumper on P3 for Z5 and Z6 as shown in Figure 5.

There are a total of 6 input zones available on the 7835C.

- Zones 1 and 2 are selectable for either a (+V) or (GND) trigger with jumper P2.
- Zones 3, 4, 5 and 6 are set up strictly for a (+V) trigger. A positive voltage applied to these zones will trigger an alarm. For added flexibility, each zone may be programmed individually to "invert" its input so that a positive voltage is removed from the zone input to trigger an alarm.

Other zone options include:

- Telco fault input (triggered when the phone line to the control panel loses voltage).
- Open/Close reporting (triggered when the user arms and disarms the alarm control panel). An additional monthly charge is applicable to this service.
- Steady or pulsing on input.

If using zone mode, run a wire for each input zone. A single common ground between the radio and control is also required. The alarm and power wires must be routed through the back of the 7835C. The ground wire should be run from the alarm panel. The wire access port is located between the terminal block and the battery on the back cover. Refer to Figure 3 for terminal block positions. Refer to the following wiring diagrams corresponding to the installation's configuration.

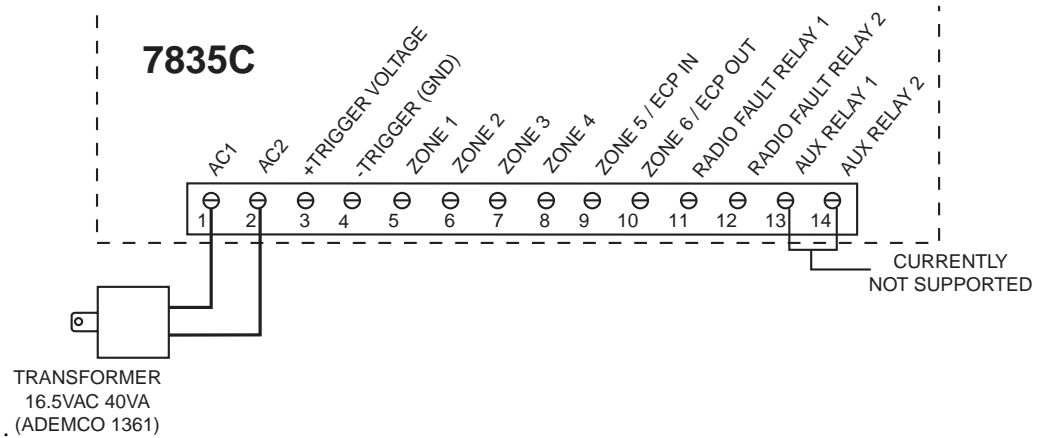

Figure 3. 7835C Terminal Block



Figure 4. 7835C P2 Jumper Configuration



Figure 5. 7835C P3 Jumper Configuration

If using zone mode, connect a wire from the triggering source (bell output, voltage trigger, etc.) to each zone on the radio to be used. Examples of zone connections are shown in Figures 6, 7 and 8.

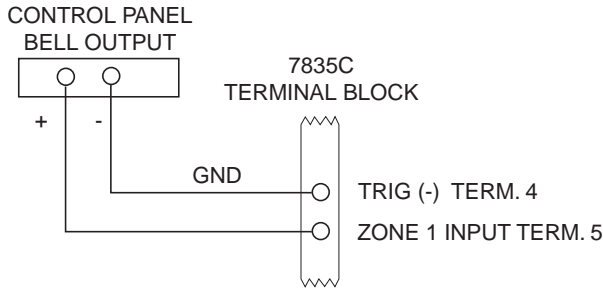

Figure 6. Wiring the 7835C zone 1 Input to trigger on (+) Bell Output voltage

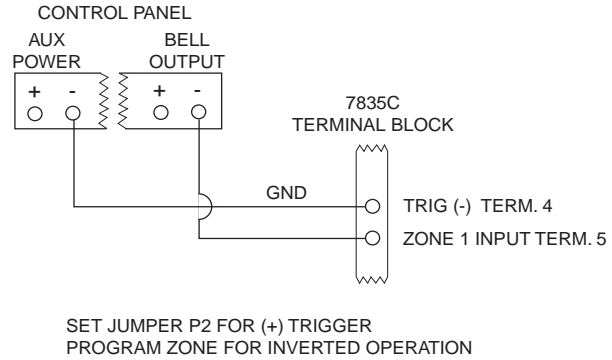

Figure 7. Wiring the 7835C zone 1 Input for ground triggered bell output

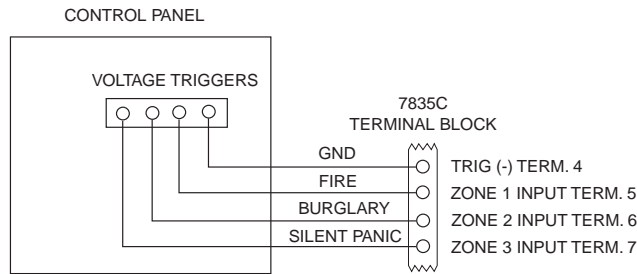

Figure 8. Wiring the 7835C zone inputs to voltage triggers, which generate (+) voltage on each wire for different alarm conditions

If the alarm control panel is activating an output relay that will be used to apply voltage to one of the input zones on the radio, do the following:

1. Connect the arm (common) of the relay to 12VDC.
2. Connect the N.O. contact of the relay to the input zone. When the relay is activated, voltage will be applied to the zone, causing the radio to send its message (see Figure 9).

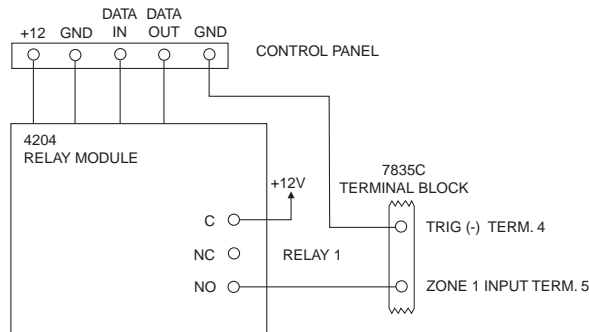

Figure 9. Wiring the 7835C zone 1 input to be triggered by an ADEMCO 4204 output relay

Wiring and Configuring ECP Communication (ECP Options)

The 7835C supports ECP messaging to communicate directly with the control panel. Only certain panels support ECP data communication at this time (i.e., ADEMCO’s VISTA-10, VISTA-20, Via-30P and VISTA-128FB). Select this mode of operation with jumper P3. When P3 is in the ECP position, zone 5 and zone 6 become ECP IN and ECP OUT, respectively. When using ECP, zones 1 through 4 cannot be used.

Connect the 7835C in parallel with keypads and other peripheral devices such as RF receiver, VIP module, etc., that use ECP. To wire the radio for ECP communication, do the following:

1. Connect terminal 9 on the 7835C to Data Out terminal of the alarm control panel.
2. Connect terminal 10 on the 7835C to the Data In terminal of the alarm control panel.
3. Connect terminal 4 on the 7835C to the Ground terminal of the alarm control panel.

Wire length/gauge limitations are the same for the control panel keypads as they are for the radio. Refer to the control panel Installation Instructions.

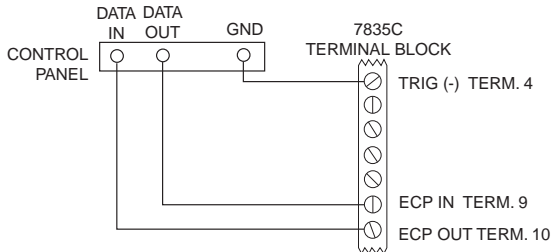

Figure 10: Wiring the 7835C for ECP data communication

ECP Status Codes

When the 7835C is configured for ECP mode, it sends status messages to the control for battery, AC power, tamper and RF failures. The status is displayed on the control’s keypad as “Long Rnge Fail” followed by a 4-digit code. These code are listed below, as well as Contact ID codes sent to the central station.

Keypad		Contact ID	
Status Code	Explanation	Code*	Meaning
0000	Control lost communication with 7835C	R330 C8xx**	Restore of RF faults
3000	7835C lost AC power		(restore of peripheral trouble)
0880	7835C tamper detected (cover removed)	E337 C8xx**	ECP DC loss
0060	7835C low battery	R337 C8xx**	ECP DC restore
0005	7835C has lost contact with AlarmNet	E338 C8xx**	ECP low battery
0006	7835C EEPROM and/or RAM is corrupt (bad CRC)	R338 C8xx**	ECP low battery restore
0009	7835C hardware failure; requires factory service	E339 C8xx**	ECP power-on reset
000D	7835C radio account is no longer active	E341 C8xx**	ECP tamper
000F	7835C is not registered; radio account not activated	R341 C8xx**	ECP tamper restore
		E355 C000	radio lost comm. with control
		R355 C000	radio restore comm. w/control

* as displayed on 685 Digital Receiver
 ** xx = 7835C device address

Wiring for Radio Faults

You may program the radio fault output relay (refer to *Programming the 7835C* section) for either:

FAIL-SAFE mode	LOW CURRENT mode
<ul style="list-style-type: none"> • Answer “Y” to “FLT REL ON (Y/N)” • Relay always energized [N.C.] • Relay will change state (and trigger a dialer, if connected) in the event of power loss. • Fail-safe mode increases the standby current by about 10mA, which results in lower battery backup time (about 15%) in the event of power loss. 	<ul style="list-style-type: none"> • Answer “N” to “FLT REL ON (Y/N)” • Relay normally de-energized [N.O.] • Does not increase standby current

Run two wires from the 7835C’s radio fault terminals 11 and 12 to a zone on the control panel. Refer to the Figures below for wiring the radio fault relay.

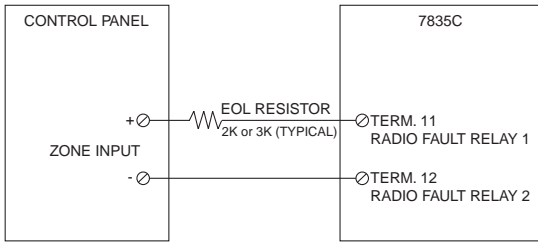

Figure 11. Wiring the 7835C to trip a control panel zone during a radio fault

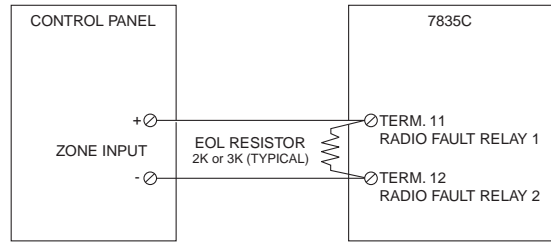

Figure 12. Wiring the 7835C to trip a control panel zone for normally open fault

AC Power Connections

Primary power for the 7835C is provided by a wall-mounted 16.5VAC / 40VA transformer ADEMCO PN: 1361. Use of a transformer with a lower power rating will result in unreliable system operation.

Connect the AC power wires from the 16.5V 40VA wall transformer to terminals 1 and 2 on the 7835C. Do not plug the transformer into the AC power source until all wiring connections have been made and you are ready to power up the 7835C. Refer to the *7835C Initial Power-Up Sequence* section.

Backup Battery Connection

The optional battery backup (ADEMCO 7720BT) can provide up to 4 hours of system life in the event of an AC power failure. When AC power is lost, the 7835C enters a low-power state and the programmable AC loss message can alert the AlarmNet Control Center (AC loss messages are reported within 10-40 minutes of actual AC loss). Any alarms that are tripped during this low-power state will wake the system up to transmit the appropriate message. After a successful transmission, the 7835C will reenter its low-power state. When the battery reaches 10.5V, a low-battery message is transmitted, which alerts the AlarmNet Control Center that this may be the radio’s last message. When the battery reaches 8.5V, radio transmissions are no longer possible and the system shuts down. If AC power is restored before the system shuts down, an AC Restore message will be sent and the battery will be recharged using the 7835C’s built-in battery charger. If AC power is restored after the system has shut down, a power-on reset condition exists, and the radio will initialize itself as described earlier and the battery will be recharged.

The 7835C performs a battery test under load on a daily basis. During this test, if the battery drops below 10.5V, a low-battery message will be generated to indicate that the battery should be replaced.

To install the battery, snap it into the battery holder with the connector wire towards the lower right. Do not plug the battery in until all wiring connections have been made and you are ready to power up the 7835C. Refer to *7835C Initial Power-Up Sequence* section. When you are ready to power up the radio, plug the battery connector into the battery jack located on the right-hand side of the 7835C terminal strip.

Lower cover must be in place for the 7835C to enter its lower power state during battery operation.



Section 7. Operation Overview

LED Indications

The 7835C has two sets of LED displays: Radio Status LEDs and a multi-function bar graph.

Radio Status: Green, yellow, and red LEDs, which provide information on pending messages, successful or unsuccessful message transmission, network connectivity, and registration status. Refer to Table 6 below.

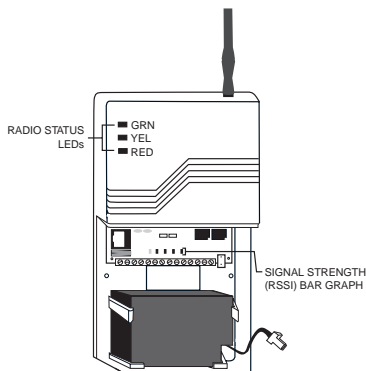

LED Displays

LED	PATTERN	MEANING
Green	Flash	With solid yellow, successful message transmission
	Solid	With flashing yellow, network contact but radio is unregistered
Yellow	Solid	Message pending
	Flash rapidly, continuous	Waiting for message validation after successful transmission
	Flash, once per sec Flash, twice per sec	Normal operation, connected to "B" side carrier Normal operation, connected to "A" side carrier
Red	Solid	No network contact / RF fault
	Periodic flash	ECP mode only: loss of communication with control
	Flash rapidly, continuously	RF fault (unsuccessful transmission) and ECP fault
	Flash rapidly, briefly	Transmit error (refer to transmit error codes diagram on next page)
All	Solid	Power on, LED Test
	Rapid chaser	Power on reset condition
	Slow chaser	Program mode accessible, radio previously programmed
	Slow flash in unison	Program mode accessible, radio previously unprogrammed

Bar Graph Indications

Signal Strength: Viewed with the cover removed (refer to *Removing the Cover* section), this display consists of one yellow and four green LEDs arranged in a bar graph. It indicates the signal strength at which the 7835C is receiving the local cell. The display is intended as an installation aid for determining a suitable mounting location. Refer to *Selecting a Radio Installation Site* section for an explanation of its use.

Power-Up: During power-up, the bar graph LEDs are used to monitor radio initialization, and is read from right to left. Refer to the *7835C Initial Power-Up Sequence* section for details.

Registration: The bar graph display also monitors the radio's registration progress. Refer to *Registering the Radio* section for detailed information.

Transmit Error: The bar graph LEDs also indicate failed message transmission error codes by the number of lit segments. Refer to the *Transmitting an Alarm* paragraph on the next page for details.

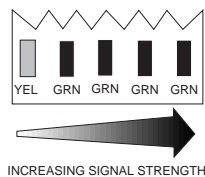

Signal Strength Bar Graph

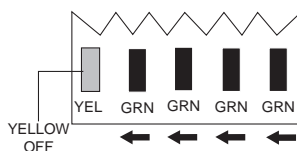

Initial Power-Up Display

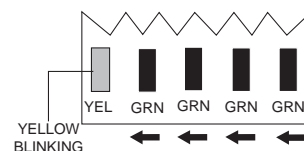

Radio Registration Display

PATTERN	MEANING
Solid	Power on, LED Test.
Rapid chaser	Power on reset condition.
From left to right, one or more LEDs are lit, with the leading LED either solid or blinking.	Normal RSSI display. Refer to Figure 2 and "Selecting a Suitable Installation Site" section for a description of this display.
Yellow LED not lit, green LEDs sequentially being lit from right to left – counting down.	Radio initial power-up sequence. This display will only be seen when the 7835C is being powered up (refer to "Initial Power-Up" section).
Yellow is blinking, green LEDs sequentially being lit from right to left – counting down.	Radio registration sequence. This display will only be seen when the 7835C is being registered. Refer to <i>Registering the Radio</i> section.
Flash in unison	Radio initial power-up or registration unsuccessful.

Normal Operation

With the 7835C installed, programmed, and registered, and after a successful transmission of the Power on Reset message, the 7835C enters normal operation. Normally, with good cellular coverage and no messages pending, the yellow status LED will flash in one of two patterns indicating the operating carrier.

- Yellow flashing once per second indicates no alarm messages are pending and that the 7835C is connected to a cell being operated by the “B” side carrier.
- Yellow flashing twice rapidly, then a pause every second, indicates no alarm messages are pending and the cell that the 7835C is in contact with is operated by the “A” side carrier.

Refer to Table 6 for all LED patterns



Note that at any point during operation, a solid red LED indicates that contact with the cell has been lost. The 7835C will automatically attempt to regain contact with the cell. If contact is not regained before the programmed radio fault time, the radio fault relay will change state, sending a radio fault to the panel. Refer to Table 6 for all LED patterns.

Transmitting an Alarm

While in normal operation, triggering any zone or reception of a valid ECP message will initiate the transmission of an alarm. The yellow status LED will light solid, indicating a message pending. The green LED will flash rapidly 6 times when the alarm message has been successfully transmitted. The yellow LED will begin to flash rapidly, indicating the 7835C is waiting for a message validation from AlarmNet Control. This may take several minutes to receive, since the validation is a low priority message. When the 7835C receives the validation from AlarmNet, the yellow LED resumes its normal blinking pattern. If the 7835C does not receive a validation within 90 seconds of a successful transmission, it will retransmit the alarm. The 7835C will continue to retransmit an unvalidated alarm once every 90 seconds until the message is validated, or the “old alarm time” has expired. If the message is not validated, the alarm is removed and the 7835C resumes normal operation. When the zone restores, if zone restoral has been programmed, the restoration message will be transmitted and the validation will be received with the same LED patterns. Refer to Table 6 for LED patterns.

The red LED will flash 15 times and the yellow LED will remain solid any time a transmission is unsuccessful. Additionally, the bar graph LEDs will display an error code (refer to the diagram below). The 7835C will automatically attempt retransmission of the alarm within 10 seconds. The radio will continue to retransmit until it is successful, unless a radio fault has been generated (the red LED lights solid on). Refer to Table 6 for LED patterns.

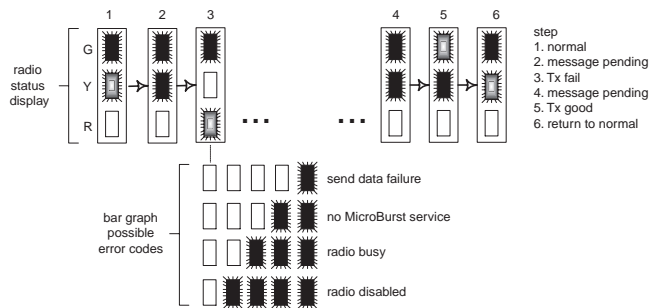

LED Key:



Transmit Error Codes as Displayed on the Bar Graph

(Note: Green Radio Status LED is lit, indicating an unregistered radio)

Radio Supervision

The 7835C periodically transmits supervisory and status messages to alert the network that it has communication integrity. The supervision period (window) is a programmable feature (see Question 5). If no messages are received by the AlarmNet Control Center during the supervisory window, a communication failure signal is routed via RF to the appropriate AlarmNet–A or AlarmNet–M equipped central station.

Swinger Suppression

Swinger suppression applies to registered radios that are operating in zone mode only. If a zone triggers more than 6 times in 8 minutes, it’s a swinger. The radio will transmit a diagnostic message indicating the suppressed zone to the CS. Locally, the 7835C will blink the amber radio status led once every time the suppressed zone is triggered. In this condition, the 7835C will not transmit alarms from the suppressed zone for a period of 8 hours. After 8 hours, the zone will return to normal operation. If the swinger condition still exists, the zone will again be suppressed after 8 minutes.

Section 8. Keyboard Commands

Radio Transmission Test

The 7835C can send a test message that can be received by the central station to confirm the radio's communication link. You should perform this test once the 7835C has been registered. The test message can be transmitted in either of two ways:

- 1) A 7720P Programming Tool can be used, if connected to the programming connector of the 7835C. To send a test message, press SHIFT-8 (T command). The 7720P will display a message sent. The yellow Radio Status LED will blink rapidly until message validation is received from AlarmNet.
- 2) Pressing the tamper switch once will cause the 7835C to send a test alarm to the central station. The green LED will blink and the yellow LED will extinguish when the message has been delivered and validated.

System Test

If the zone is programmed for restore, restore the circuit. The yellow LED should light solidly, and the green transmit LED should flash, indicating transmission of the restore message. The central station receiver should display alarm/restore messages for each triggered alarm/restore performed. Replace the cover (if it was removed) and perform a control panel system test.

7720P Keyboard Commands

"A"

7835C x.xx (c) Pittway 1998

Software Revision
Display the installed software Revision.

"B"

NET OK -xxxDBM Z MIN xxx-xxx-xxxx

Radio & Connectivity Display
"NET OK" indicates that the 7835C is in contact with a local cell and AlarmNet.
"-xxxDBM" is the numeric value of the RSSI bar graph. It indicates the power level at which the 7835C is receiving the local cell. Note: -dBm is a measure of power; decibels less than a milliwatt. A reading of -98DBM is a better signal than -104DBM.
"Z" = A or B carrier
"MIN xxx-xxx-xxxx" is the radio's unique identification number

NET NS -xxxDBM Z MIN xxx-xxx-xxxx

"NET NS" (no service) indicates the 7835C is in contact with a local cell but has no AlarmNet service.
"Z" = A or B carrier

NO CONTACT MIN xxx-xxx-xxxx

"NO CONTACT" indicates that the 7835C has lost contact with the local cell and AlarmNet.

"C"

NET TIME

"NET TIME" displays the network time.

"E"

Channel = xxx Sys=x SID=z xxxx

Network System Display
"Channel = xxx" indicates the control channel that the 7835C is using to communicate with the local cell.
"Sys=x" indicates the local carrier ("A" side or "B" side) that the 7835C is connected with.
"SID=z xxxx" is the System Identification Number, the unique ID number for each cellular carrier, where:
"z" is the international identifier code:
0 = United States
1 = other countries
2 = Canada
3 = Mexico
"xxxx" is a numeric value from 0000 – 1023

“F”	A mz xxxx B mz xxxx PREF *	Carrier Display * = Carrier currently selected “xxxx” is the System Identification Number “z” = the international identifier code where: 0 = United States 1 = other countries 2 = Canada 3 = Mexico “M” = MicroBurst service found. Blank if not found. “PREF” = Preferred side selected in question 7
“D”	Bat Test Start Hit S to Chk	Battery Test This selection initiates a 10-min. battery test. The charger is removed from the battery and a load is applied for 10 min. The “S” command can be used to monitor the battery condition throughout the test.
“S”	123456TmBaAcFlt 555555 6 + + 0	Status Display The status of the 7835C can be viewed on the 7720P. The status display includes zone input status, test terminal status, tamper status, battery condition, charging voltage status, and radio fault status. Status Display Interpretation for “S” Command 123456 The numbers 1-6 represent the 6 zone inputs, and follow ADEMCO High Speed Format codes: 1 New Event 2 New Opening 3 Restore 4 New Closing 5 Normal 6 Previously Reported Event @ Telco New Event P Telco Previously Reported p Telco Restore Tm Tamper status follows High Speed Format codes above. Ba Represents battery condition: + Battery voltage acceptable – Battery voltage below 10.5V ± 5% V Battery voltage going low has not yet been sent to the central station (appears only briefly) X Battery not installed Ac Represents line voltage: + AC line voltage OK – AC line voltage bad & reported V AC line voltage bad, not reported (reporting window not expired) ^ AC voltage restored, not reported as restored Flt Represents Radio Faults: 0 Normal 5 No contact with AlarmNet (check antenna, connections) 9 Hardware failure; requires factory service CRC RAM/EEROM corruption. Reset the radio and, if necessary, reprogram. If this fault recurs, return radio for service.
“T”	Test Alarm Sent	Test Alarm Send a Test alarm to AlarmNet. Functional for registered 7835C’s only.
“X”	Reset (Y/N)	Reset the 7835C. This will be the display following the “X” command. Answering “N” will return to normal mode. Answering “Y” will reset the radio and display the following:
	Resetting!	

Section 9: Troubleshooting

Problem	Probable Cause	Solution
7835C not being received at the central station. Message transmit successful; yellow LED extinguishes, green LED flashes 6 times.	Programming (subscriber number, central station ID number, or city number.)	Verify and correct programming entry with the 7720P. Refer to the Programming section.
7835C not being received at the Central station. Message transmit not successful. Yellow LED is lit solid, red LED flashes 6 times.	Antenna location or installation.	Remove 7835C cover, check RSSI level with a 7720P or the bar graph. Select a better mounting location. Refer to "Selecting a Suitable Installation Site". Ensure the antenna connector is not damaged or obstructed. Ensure the antenna is screwed down securely.
During installation, with cover removed, using battery power and wall transformer not plugged in, 7835C not being received at the central station. Message transmit not successful. Yellow LED is lit solid, red LED flashes 6 times.	Battery is low.	Replace battery with a fully charged battery or plug in the wall transformer.
Radio fault, solid red LED on the Radio Status display.	Antenna location or installation.	Remove 7835C cover, check RSSI level with a 7720P or the bar graph. Select a better mounting location. Refer to "Selecting a Suitable Installation Site" section. Ensure the antenna connector is not damaged or obstructed. Ensure the antenna is screwed down securely.
Low Battery message sent with cover installed and wall transformer installed, during normal operation .	AC voltage supply	AC power loss, excessive AC wire run, or incorrect transformer.
	Environment.	If temperature exceeds -30°C to 60°C, this will diminish battery capacity and or life. Replace battery if required.
Tripping a zone or valid ECP message does not generate a message pending display; solid yellow LED	No connection ground.	Connect (-) trigger output (TB Pin 4) to the panel ground.
	Incorrect trigger input.	Verify type of input. Check P2 & P3 configuration. Application of +4.5 to 12 volts (Non-Inverted). Check programmed trigger levels. Absence of +4.5 to 12 volts (Inverted). Check wiring.
	Incorrect jumper settings. P2 & P3	See Setting the Jumper Options.
Radio will not initialize. The 5 RSSI LEDs blink in unison during initial power-up.	Data stored in EEPROM is corrupt.	Connect the 7720P and enter programming mode. Skip all programming questions and restore factory defaults as described in Programming section.
Radio will not register.	Error in programmed features.	Verify programmed options. Change as required.

FEDERAL COMMUNICATIONS COMMISSION (FCC) Part 15 STATEMENT

This equipment has been tested to FCC requirements and has been found acceptable for use. The FCC requires the following statement for your information:

This equipment generates and uses radio frequency energy and if not installed and used properly, that is, in strict accordance with the manufacturer's instructions, may cause interference to radio and television reception. It has been type tested and found to comply with the limits for a Class B computing device in accordance with the specifications in Part 15 of FCC Rules, which are designed to provide reasonable protection against such interference in a residential installation. However, there is no guarantee that interference will not occur in a particular installation. If this equipment does cause interference to radio or television reception, which can be determined by turning the equipment off and on, the user is encouraged to try to correct the interference by one or more of the following measures:

- If using an indoor antenna, have a quality outdoor antenna installed.
- Reorient the receiving antenna until interference is reduced or eliminated.
- Move the radio or television receiver away from the receiver/control.
- Move the antenna leads away from any wire runs to the receiver/control.
- Plug the receiver/control into a different outlet so that it and the radio or television receiver are on different branch circuits.

If necessary, the user should consult the dealer or an experienced radio/television technician for additional suggestions. The user or installer may find the following booklet prepared by the Federal Communications Commission helpful: "Interference Handbook"

This booklet is available from the U.S. Government Printing Office, Washington, DC 20402.

The user shall not make any changes or modifications to the equipment unless authorized by the Installation Instructions or User's Manual. Unauthorized changes or modifications could void the user's authority to operate the equipment.

THIS DEVICE COMPLIES WITH PART 15 OF FCC RULES AND WITH RSS-210 OF INDUSTRY AND SCIENCE CANADA. OPERATION IS SUBJECT TO THE FOLLOWING TWO CONDITIONS: (1) THIS DEVICE MAY NOT CAUSE INTERFERENCE, AND (2) THIS DEVICE MUST ACCEPT ANY INTERFERENCE, INCLUDING INTERFERENCE THAT MAY CAUSE UNDESIRE OPERATION OF THIS DEVICE.
ISC: RSS/CNR 210

Summary of Connections

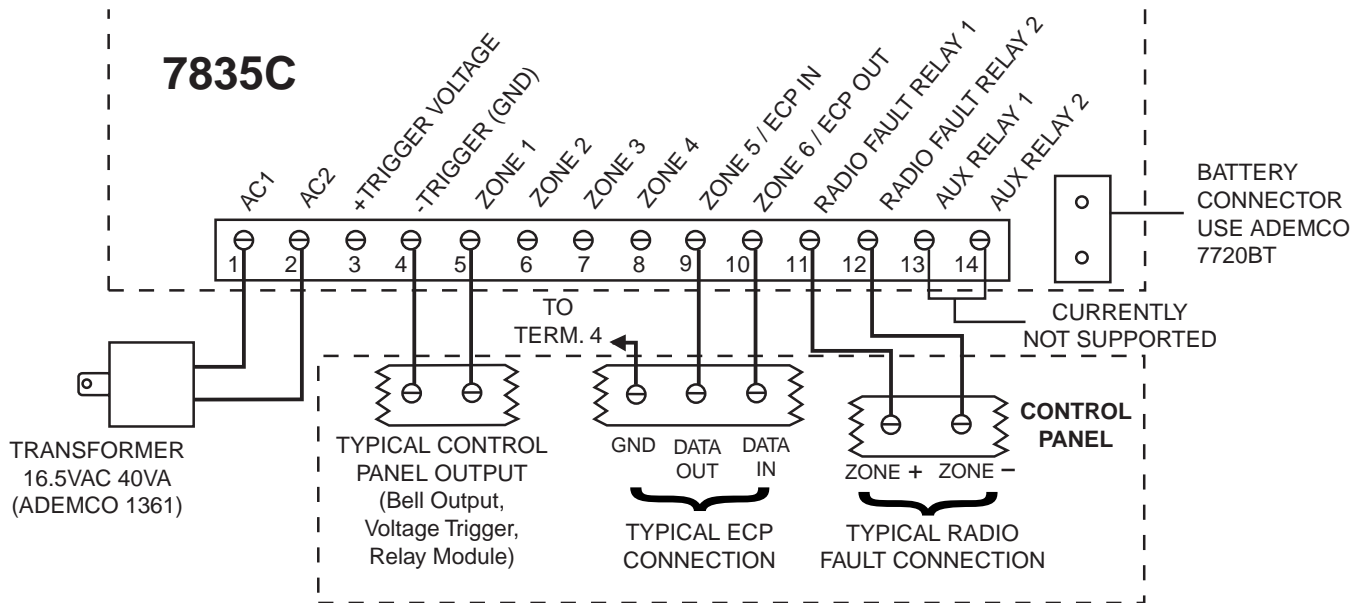

7835C SUMMARY OF CONNECTIONS DIAGRAM

ADEMCO LIMITED WARRANTY

Alarm Device Manufacturing Company, a Division of Pittway Corporation, and its divisions, subsidiaries and affiliates ("Seller"), 165 Eileen Way, Syosset, New York 11791, warrants its products to be in conformance with its own plans and specifications and to be free from defects in materials and workmanship under normal use and service for 24 months from the date stamp control on the product or, for products not having an Ademco date stamp, for 12 months from date of original purchase unless the installation instructions or catalog sets forth a shorter period, in which case the shorter period shall apply. Seller's obligation shall be limited to repairing or replacing, at its option, free of charge for materials or labor, any product which is proved not in compliance with Seller's specifications or proves defective in materials or workmanship under normal use and service. Seller shall have no obligation under this Limited Warranty or otherwise if the product is altered or improperly repaired or serviced by anyone other than Ademco factory service. For warranty service, return product transportation prepaid, to Ademco Factory Service, 165 Eileen Way, Syosset, New York 11791.

THERE ARE NO WARRANTIES, EXPRESS OR IMPLIED, OF MERCHANTABILITY, OR FITNESS FOR A PARTICULAR PURPOSE OR OTHERWISE, WHICH EXTEND BEYOND THE DESCRIPTION ON THE FACE HEREOF. IN NO CASE SHALL SELLER BE LIABLE TO ANYONE FOR ANY CONSEQUENTIAL OR INCIDENTAL DAMAGES FOR BREACH OF THIS OR ANY OTHER WARRANTY, EXPRESS OR IMPLIED, OR UPON ANY OTHER BASIS OF LIABILITY WHATSOEVER, EVEN IF THE LOSS OR DAMAGE IS CAUSED BY THE SELLER'S OWN NEGLIGENCE OR FAULT.

Seller does not represent that the products it sells may not be compromised or circumvented; that the products will prevent any personal injury or property loss by burglary, robbery, fire or otherwise; or that the products will in all cases provide adequate warning or protection. Customer understands that a properly installed and maintained alarm may only reduce the risk of a burglary, robbery, fire or other events occurring without providing an alarm, but it is not insurance or a guarantee that such will not occur or that there will be no personal injury or property loss as a result. CONSEQUENTLY, SELLER SHALL HAVE NO LIABILITY FOR ANY PERSONAL INJURY, PROPERTY DAMAGE OR OTHER LOSS BASED ON A CLAIM THE PRODUCT FAILED TO GIVE WARNING. HOWEVER, IF SELLER IS HELD LIABLE, WHETHER DIRECTLY OR INDIRECTLY, FOR ANY LOSS OR DAMAGE ARISING UNDER THIS LIMITED WARRANTY OR OTHERWISE, REGARDLESS OF CAUSE OR ORIGIN, SELLER'S MAXIMUM LIABILITY SHALL NOT IN ANY CASE EXCEED THE PURCHASE PRICE OF THE PRODUCT, WHICH SHALL BE THE COMPLETE AND EXCLUSIVE REMEDY AGAINST SELLER. This warranty replaces any previous warranties and is the only warranty made by Seller on this product. No increase or alteration, written or verbal, of the obligations of this Limited Warranty is authorized.

ADEMCO
GROUP

165 Eileen Way, Syosset, NY 11791
Copyright © 1998 PITTWAY CORPORATION



K3204 9/98