



**® ADEMCO**

**Control/Communicator**

***5110XM***

**Installation Instructions • Installation Instructions • Installation Instructions**

# TABLE OF CONTENTS

<b>Section 1:</b>	<b>GENERAL DESCRIPTION</b> .....	<b>6</b>
	Basic Hardwired.....	6
	Remote Keypads .....	6
	User Codes .....	6
	Keypad Emergency Keys .....	6
	Backup Dialer .....	6
	Bell Output .....	7
	Auxiliary Relay .....	7
	Built-in Indicators and Switches.....	7
	Programming .....	7
	Communication Formats Supported .....	7
	AC Power Input.....	7
	Auxiliary Power Output .....	7
	Back-Up Battery .....	8
	Agency Listings.....	8
<b>Section 2.:</b>	<b>INSTALLING THE CONTROL</b> .....	<b>9</b>
	Getting the Control Up and Running.....	9
	Mounting the Cabinet .....	9
	Installing the Lock .....	9
	Mounting The Control's Circuit Board .....	10
	Standard Phone Line .....	11
	Enabling the Dialer .....	11
	Telephone Line Supervision .....	11
	Dialer Operation .....	11
	Connecting the AC Transformer .....	12
	Earth Ground .....	12
<b>Section 3:</b>	<b>INSTALLING REMOTE KEYPADS</b> .....	<b>13</b>
	Wiring To The Keypads .....	13
	Mounting the Keypads .....	14
	Preliminary Check-out Procedure .....	14
<b>Section 4:</b>	<b>MECHANICS OF PROGRAMMING</b> .....	<b>15</b>
	Entering Program Mode .....	15
	Programming a Data Field.....	15
	Exiting the Programming Mode .....	16
<b>Section 5:</b>	<b>BASIC HARD-WIRED ZONES 1-5</b> .....	<b>17</b>
	General Information about Hardwired Zones .....	17
	Wiring Devices To Zones 1-5 .....	17
	Wiring 4-Wire Smoke/Combustion Detectors on Zones 1-5. ....	17
	Wiring 2-Wire Smoke Detector .....	18
	Fire Alarm Verification for Smoke Detectors .....	19
	Turning Off Fire Alarm Sounding .....	19
	Programming Hard-Wired Zones .....	20
	Check-Out Procedure For Detection Zones .....	21
<b>Section 6:</b>	<b>SYSTEM ZONES</b> .....	<b>23</b>
	General Information .....	23
	System Zone Assignments .....	23
<b>Section 7:</b>	<b>ALARM INDICATING DEVICES</b> .....	<b>24</b>
	General Information .....	24
	Sounder Connections .....	25
	Programming for External Sounders .....	25
	Testing the Sounder .....	26
<b>Section 8:</b>	<b>AUXILIARY RELAY CONNECTIONS</b> .....	<b>27</b>
	General Information .....	27
	Relay Connections .....	27
	Programming the Auxiliary Relay .....	28
<b>Section 9.</b>	<b>FINAL POWER UP</b> .....	<b>29</b>
	AC Power Connections.....	29
	Earth Ground .....	29
	Powering Up the System .....	30
	Connecting The Back-Up Battery .....	30
	Calculating the Battery Size .....	30
	Battery Supervision.....	33
<b>Section 10:</b>	<b>Alpha Descriptor Programming</b> .....	<b>34</b>

	Assigning Zone Descriptors .....	34
	Entering Zone Descriptors .....	34
	Programming the Descriptors .....	34
	Alternate Method For Programming Zone Descriptors .....	36
	Adding Custom Words .....	37
	ALPHA VOCABULARY LIST .....	38
	CHARACTER (ASCII) CHART .....	39
<b>Section 11:</b>	<b>SYSTEM COMMUNICATION .....</b>	<b>40</b>
	General Information .....	40
	Report Code Formats .....	40
	TABLE OF CONTACT ID EVENT CODES .....	42
	Programming Communication Options .....	43
<b>Section 12:</b>	<b>Zone Response Type Definitions .....</b>	<b>47</b>
	General Information .....	47
	Zone Response Types .....	47
<b>Section 13:</b>	<b>DATA FIELD DESCRIPTIONS .....</b>	<b>49</b>
	Description of System Data Fields .....	49
<b>Section 14:</b>	<b>REMOTE PROGRAMMING .....</b>	<b>56</b>
	General Information .....	56
	Equipment Required .....	56
	Initial Download .....	56
	Remote Programming Information .....	57
<b>Section 15:</b>	<b>SYSTEM OPERATION .....</b>	<b>58</b>
	User Codes .....	58
	Keypad Functions .....	59
<b>Section 16:</b>	<b>TESTING THE SYSTEM .....</b>	<b>60</b>
	Dialer Test .....	61
	Trouble Conditions .....	61
	General Information .....	61
	Telephone Line Failure .....	61
	Power Failure .....	61
	Other Displays .....	61
<b>Section 17:</b>	<b>TROUBLESHOOTING GUIDE .....</b>	<b>62</b>
	CONTACTING TECHNICAL SUPPORT .....	63
<b>Section 18:</b>	<b>SPECIFICATIONS &amp; ACCESSORIES .....</b>	<b>64</b>
	Specifications .....	64
	AGENCY LISTINGS .....	65
	Accessories .....	66
	Sounders .....	66
	Compatible 2-Wire Smoke Detectors .....	66
	<b>REGULATORY AGENCY STATEMENTS .....</b>	<b>67</b>

## LIST OF FIGURES

Figure 1.	Installing the cabinet lock .....	10
Figure 2.	Mounting the 5110XM pc board .....	10
Figure 3.	Keypad connections to the Control board .....	14
Figure 4.	4-wire smoke detector connections .....	18
Figure 5.	2-wire smoke dectector connections .....	19
Figure 6.	Sounder wiring .....	25
Figure 7.	Wiring the auxiliary relay output for unsupervised alarm output .....	27
Figure 8.	Wiring the auxiliary relay output for 4-wire smoke detector power usage .....	27
	Ademco 5110XM Summary of Connections .....	Inside Back Cover

# HOW TO USE THIS MANUAL

This manual is written to accommodate both the new and the experienced installer of Ademco products. A general description of the entire system is located at the beginning of the manual. The wiring and physical setup of the hardware follows.

The sections at the core of the manual include both hardware setup and programming requirements of each device to make that specific device operational in the system. A checkout procedure is included at the end of each section. We recommend this method to ensure that each device is working properly before proceeding to the next section. It must also be used if you are making a particular addition to the system of one of these devices.

Each of the sections covering the installation of peripheral devices includes the programming for that device. Without an understanding of the programming of the system, you will not be able to successfully perform the required programming in each of these sections. We therefore urge you to read the *Mechanics of Programming* section before any programming is performed.

If you are an experienced user of Ademco products, you may choose to wire and then program the entire system at once. If so, refer to the *Mechanics of Programming* section and the *Data Field Descriptions* section after the hardware setup is complete. A blank pull-out programming form is included with this manual.

This manual uses various icons to denote critical notes and technical tips to assist you with the installation of this system. These are easily seen in the left-hand column of the relevant information.

# CONVENTIONS USED IN THIS MANUAL

## MAIN SECTION TITLES ARE SHOWN IN REVERSE TYPE

Before you begin using this manual, it is important that you understand the meaning of the following symbols (icons).

**UL**

These notes include specific information which must be followed if you are installing this system for a UL Listed application.



These notes include information that you should be aware of before continuing with the installation, and which, if not observed, could result in operational difficulties.



This symbol indicates a critical note that could seriously affect the operation of the system, or could cause damage to the system. Please read each warning carefully. This symbol also denotes warnings about physical harm to the installer.

Enter Zn Num. (00 = Quit)                      01
--

Many system options are programmed in an interactive mode by responding to Alpha keypad display prompts. These prompts are shown in a double-line box.

**\*00**

When programming the system, data fields are number.

**PRODUCT MODEL NUMBERS:** References to specific model numbers, unless noted otherwise, represent Ademco products.

# Section 1. GENERAL DESCRIPTION

The Ademco 5110XM is a UL Listed, microprocessor-based fire alarm control/communicator that supports 5 style B (for further explanation of style B, refer to NFPA 72 National Fire Alarm Code Chapter 3: Protected Premises Fire Alarm Systems) hardwired zones. It may be used as a slave Digital Alarm Communicator Transmitter (DACT) providing central or remote station service for a central or remote station listed Fire Alarm Control Panel (FACP). It may also be used as a standalone non-coded local, central station or remote station control.

## Basic Hardwired Zones

Provides 5 style B hardwired zones having the following characteristics:

- EOLR supervision supporting N.O./N.C. sensors such as smoke detectors, water flow switches, etc. or N.O./N.C. contacts from a listed fire alarm control panel
- 300 – 500ms response time
- Individually assignable to bell output and/or aux. relay
- Supports up to 16 2-wire smoke detectors on Zone 5
- Supports 4-wire smoke detectors on any zone (power to these should be supplied from the control's auxiliary relay power output; see the section on *Hardwired Zones*)
- Tolerance of 300-ohm resistance on zones 1-4, 100-ohm resistance on zone 5 (excluding EOLR)

## Remote Keypads

- When used as a DACT only, a keypad is not required, but may be used to provide supplementary status annunciation.
- When used as a control, a keypad must be used.

The following keypads may be used:

*Fixed-Word Keypads:* 6137 (gray) or 6137R (red)

*Alpha Keypads:* 6139 (gray) or 6139R (red)



A 6139 or 6139R keypad must be used for keypad programming.

## User Codes (for use with remote keypads)

- 1 Master code for entire system (user 1– intended for use by installer)
- 5 secondary user codes (users 2–6; user 2 intended for use by principle end user)

## Keypad Emergency Keys

Provides up to 3 programmable emergency key functions:

- Designated as Zones 7, 95, and 96
- Can be programmed for 24-hr. silent, audible, auxiliary, or fire responses
- Intended to be used only when the 5110XM is installed as a stand alone control.

## Backup Dialer

Has built-in backup dialer for connecting to a second supervised telephone line.

## **Bell Output**

Provides one 12VDC (nominal), 1 AMP output, which may be configured for Style Y (for further explanation of style Y, refer to NFPA 72 National Fire Alarm Code Chapter 3: Protected Premises Fire Alarm Systems), EOLR supervision (for use with polarized alarm sounding devices) or for no supervision (no EOLR used)

## **Auxiliary Relay**

Provides a built-in 12V wet or dry (jumper selectable) "Form C" relay which can be used for one of the following:

- Alarm activation on selected zones, silenced by Code + Off
- Trouble/Supervisory activation
- 4-wire smoke detector reset
- Battery saving feature (disconnects power from non-critical loads 4 hours after AC power loss)
- Alarm activation on selected zones, silenced by Code + #67 (can be used for elevator recall)

## **Built-in Indicators and Switches**

- A built-in warning buzzer that provides alarm, supervisory, and trouble sounds
- 7 LED indicators provide visual status of (1) AC Power, (2) Battery Trouble, (3) Communication Failure, (4) Telco Line Fault, (5) Silenced Audible Conditions, (6) Main Dialer Line Seize, and (7) Backup Dialer Line Seize
- A Silence/Reset push-button allows audible warnings to be silenced and smoke detectors to be reset.

## **Programming**

Programmed options are stored in electrically erasable, non-volatile EEROM memory (information can be reprogrammed at any time and will not be lost in the event of a power loss). The system can be programmed by one of the following methods:

- Uploaded, downloaded, or controlled via an IBM compatible computer, V-Link software and a HAYES modem specified by Ademco
- Programmed through an alpha keypad (6139, 6139R)

**UL**

Remote programming may only be used when a service technician is at the site during downloading.

Keypad programming consists of:

- Data field programming
- Interactive (menu) mode programming

## **Communication Formats Supported**

- Ademco Low Speed (Standard or Expanded)
- SESCOA/Radionics (Standard or Expanded)
- Ademco Express
- Ademco Contact ID

## **AC Power Input**

Uses an enclosed, permanently-wired, 120VAC transformer rated @ 18.0 VAC, 40VA (supplied) with manually resettable circuit breaker.

## **Auxiliary Power Output**

Provides 12VDC, 350 mA maximum for peripherals such as keypads. Uses Positive Temperature Coefficient Thermistors (PTCs) for protection. There are no replaceable fuses.

**Back-Up Battery**

Uses a rechargeable 12VDC, 7AH/14AH maximum lead acid (gel cell) battery for back-up power (dual battery cable supplied)

**Agency Listings**

- UL864/NFPA 72 Central and Remote Station DACT and Local, central Station and Remote Station Control.
- FM pending
- CSFM pending

## Section 2. INSTALLING THE CONTROL

This section provides instructions for getting the system up and running quickly, as well as detailed instructions for the following:

- Getting the control up and running
- Installing the cabinet lock
- Mounting the control cabinet
- Installing the main PC board
- Standard phone line connections
- Installing the back-up battery in the cabinet
- Connecting the AC transformer
- Making earth ground connections

### Getting the Control Up and Running

The following procedure is recommended for getting the 5110XM up and running quickly. Refer to each individual section (*as indicated in parenthesis*) for a more detailed overview of each step:

1. Mount the cabinet, pc board and lock (*\*see the paragraphs following this procedure for details on **Mounting the Cabinet**, and **Installing the Lock***)
2. Unpack the LED indicator pc board and plug it into the J5 header on the 5110XM PC board.
3. Wire the telephone lines, AC transformer, earth ground, optional remote keypads (if used), zones and supplementary alarm sounders (if used). (*refer to the appropriate sections as required*)
4. Program the control's telephone numbers and subscriber account numbers. Select the desired report format and program the desired report codes.  
*Refer to the section on System Communications for more information on related programming. A 6139 or 6139R must be used to program the 5110XM locally.*
5. Revise the default program selection as required.  
*Refer to the sections on Mechanics of Programming and Data Field Descriptors and the Program Form for details on the various programming options.*
6. If a remote keypad is to be permanently installed, program a user 2 code for the system's principle user. The **Master Code** as programmed in field \*20 is meant for the installer's use only and must not be given to the system's user.  
*Refer to the section on **System Operation** for details on entering user codes.*
7. Test the system to verify proper operation (*refer to the section on **TESTING THE SYSTEM***).

### Mounting the Cabinet

Mount the control cabinet to a sturdy wall using fasteners or anchors (not supplied), in a clean, dry area which is not readily accessible to the general public. Four mounting holes are provided at the back of the cabinet. When used as a slave DACT for a listed FACP, it is recommended (but not required) that the 5110XM be mounted near the FACP.

### Installing the Lock

Use an Ademco No. N6277 Cam Lock and No. N6277-1 Retainer Clip (supplied).

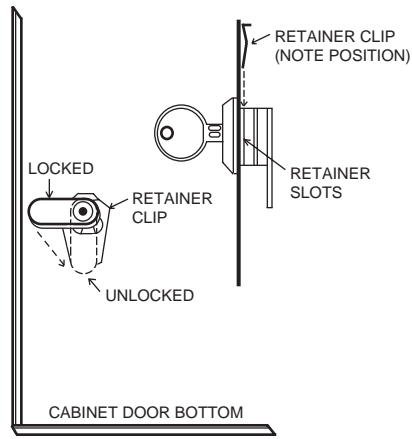

1. Remove the cabinet door. *It is easily removable for servicing and is easily re-installed.*
2. Remove the lock knockout from the control cabinet door. Insert the key into the lock. Position the lock in the hole making certain that the latch will make contact with the latch bracket when the door is closed.
3. Hold the lock steady, and insert the retainer clip into the retainer slots. Position the clip as illustrated in order to permit easy removal.

**Figure 1. Installing The Cabinet Lock**

	<p>Before installing the cabinet's contents, remove the metal cabinet knock-outs required for wiring entry. Do not attempt to remove the knockouts after the circuit board has been installed.</p>
---	--

### Mounting The Control's Circuit Board in The Cabinet

1. Hang three *black* mounting clips (provided) on the raised cabinet tabs (see Detail B in Fig. 2).
2. Insert the top of the circuit board into the slots at the top of the cabinet. Make sure that the board rests on the correct row (see Detail A ).
3. Swing the base of the board into the mounting clips and secure the board to the cabinet with the accompanying screws (see Detail B in Fig. 2).

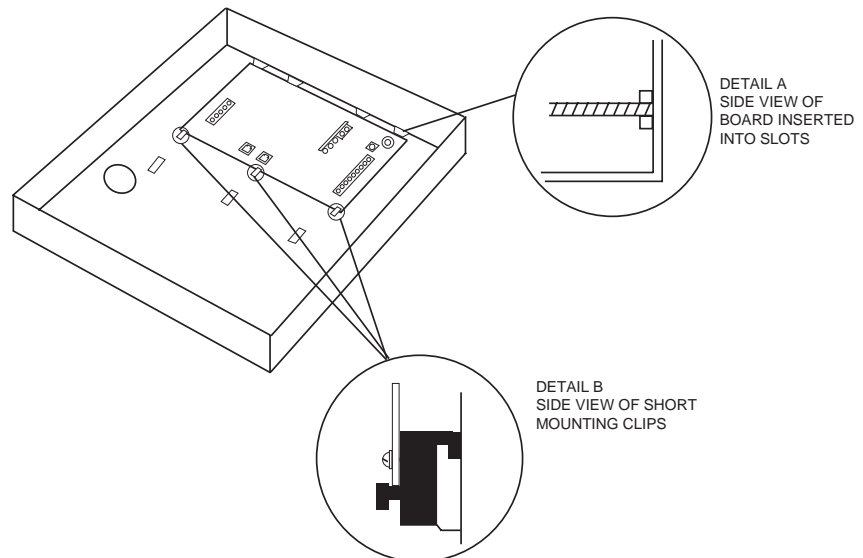

**Figure 2: Mounting the 5110XM PC Board**

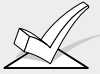
	<ol style="list-style-type: none"> <li>1. Make sure that the mounting screws are tight. This insures that there is a good ground connection between the PC board and the cabinet.</li> <li>2. Dress all wires away from microprocessor (the center section of the pc board). Use the tie-wrap loops on the left and right sidewalls of the cabinet for anchoring wires. This step is important for minimizing the risk of control radio frequency interference (RFI) with television reception.</li> </ol>
---	--

### Standard Phone Line Connections

The 5110XM provides two supervised dialer outputs: the main dialer and the back-up dialer. In fire installations, both outputs must be connected to separate telephone lines providing loop start service.

Connect the main dialer and back-up dialer (if used) outputs to telephone company lines using the RJ31X cables supplied. *Do not* connect to telephone company lines which provide ground start service.

	<p><i>DO NOT</i> connect both outputs to the same telephone line. A secondary phone line is required in case of primary phone line failure.</p>
---	---

	<ol style="list-style-type: none"> <li>1. <b>WARNING!</b> To prevent the risk of shock disconnect the telephone lines at the telco jack prior to servicing this control.</li> <li>2. If the control is connected to a PBX telephone line, make sure that the PBX system has a backup power supply that can support it for at least 24 hours (central station usage) or 60 hours (remote station usage). Many PBX systems <i>DO NOT</i> have power backup and will cause communication failures when power is lost.</li> </ol>
---	---

### Enabling the Dialer Outputs

To enable the dialer outputs, entries must be made in field \*79. Enter 1 in the first entry space to enable main dialer. Enter 1 in the second entry space to enable backup dialer.

### Telephone Line Supervision

The supervision circuits on both the main and backup dialer outputs will indicate a fault when the tip/ring voltage falls below 2 volts, provided that their supervisory zones are enabled (zones 11 and 12, respectively). These zones are enabled in field \*56 and should be assigned a response type of 19 (24-hr. trouble).

	<p>In fire installations, both outputs must be configured for line fault supervision.</p>
---	---

### Dialer Operation

When only the main dialer is enabled ([1,0] in field \*79), the 5110XM will attempt to route all calls over the main output. When both main and back-up dialers are enabled ([1,1] in field \*79), the 5110XM will attempt to route all calls over the main output unless a fault is detected, at which time it will attempt to use the back-up output. Line faults will light the line fault indicator and, if a keypad is installed, will result in a zone 11 main dialer fault or zone 12 back-up dialer fault display. The control will make up to ten attempts to transmit a report. (Ten attempts will be made to primary number when only this number is programmed. Otherwise, five attempts will be made to the primary number followed by five attempts to the secondary number when both numbers are programmed.) After the tenth attempt, the control will hang-up and will light the built-in Comm Fail indicator. A Comm Fail message will also be displayed at the keypads (if installed).



The system will not switch to the backup dialer unless it detects a fault (less than 2 volts) on the main telephone line. This means that if a report does not go through on the main phone line due to a programming error, the backup dialer will **not** be activated.

The 5110XM will transmit reports in the following order: alarms (fire, emergency), fire supervisories and troubles, then the remaining types of messages. See the *SYSTEM COMMUNICATION* section for a description of communication formats, the types of messages transmitted by the control, and for the dialer programming defaults.

### **Connecting the AC Transformer and Backup Battery**

Due to the nature of this product, the transformer must be hardwired into the premises electrical system. Therefore, we recommend wiring all zones and expansion modules according to each section's instructions *before* powering up the system for programming and testing. Refer to *Section 9: FINAL POWER UP* for specific instructions on how to connect the AC transformer and battery.

If desired, you can wire, program, and test each section individually by temporarily powering up the control and testing each section before final power up.

### **Earth Ground Connections**



The 5110XM requires connection to a good earth ground in order to provide proper 120VAC shock hazard protection, lightning transient protection, and earth ground fault detection.

Refer to the National Electrical Code for proper earth grounding methods.

To make earth ground connections, do the following:

1. Run an earth ground wire into the transformer enclosure via the same knockout used for 120VAC wiring.
2. Use a wire nut (not supplied) to splice this earth ground wire to the green flying lead located inside of and bonded to the transformer enclosure. Push the mated wires into the enclosure.
3. Connect the green flying lead which emerges from the top of the transformer enclosure to the 5110XM's earth ground terminal (Terminal 8).
4. Replace the transformer enclosure cover after wiring is complete.

## Section 3. INSTALLING REMOTE KEYPADS

This section provides the following information:

- A list of keypads that may be used
- Instructions for wiring and mounting the keypads
- A preliminary check-out procedure to ensure that the keypads are functioning properly in the system

### General

When used as a slave DACT, a keypad is not required, but may be used to provide supplementary DACT status annunciation. The keypad may be mounted wherever needed. When used as a stand-alone control, rather than a dialer, a keypad must be used and it must be mounted to an electrical box within 3 feet of the control with the wiring run in conduit.

### Keypads That May Be Used

- Fixed-Word Display: 6137, 6137R
- Alpha Display: 6139 and 6139R
- Independent of the restrictions on keypads for stand-alone control usage, the 5110XM supports up to 4 keypads provided that the 350mA current rating is not exceeded for aux. power and for the system as a whole. Fixed word and alpha keypads may be used in the same installation.

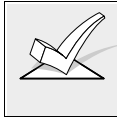

Many municipalities require that fire alarm annunciators be red in color. Check with the authority having jurisdiction before choosing a keypad color for your installation.

### Wiring To The Keypads

1. When used as a stand alone control, mount the keypad within 3 feet of the control. #22 AWG may be used to make connections to the control and must be run in conduit. When used as a slave DACT, there are no restrictions. Remote keypads may be wired to a single run or individual keypads may be wired to separate wire runs. Use the table below to determine the length of any single wire run based on the total loading on that run. The length of all wire runs combined must not exceed 900 feet if unshielded cable is used. If shielded cable is used, the combined wire run length must not exceed 450 feet.

Wire Size	100mA	200mA	300mA	350mA
#22	250'	125'	80'	71'
#20	400'	200'	130'	110'
#18	625'	310'	200'	170'
#16	900'	450'	300'	250'

Example: If you have two keypads on one wire run that draw a total of 200mA, and you are using #20 AWG wire, the distance from the Control Aux (+) and Aux (-) terminals to the last device can be up to 200 feet.

2. Run field wiring from the control to the keypads (using standard 4-conductor twisted wire cable using the wire gauge determined in step 1).
3. Connect remote keypads to terminals 17, 18, 19, and 20 on the control board, as shown in Figure 3.

KEYPAD CONNECTOR CABLE  
(supplied with keypads)

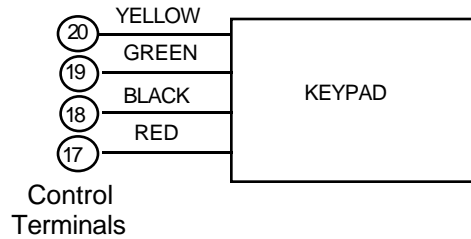

**Figure 3: Keypad Connections To The Control Board**

### Mounting the Keypads

1. **Make sure addressable type keypads** (6137, 6137R, 6139, and 6139R) are set to the non-addressable mode (address 31), which is the factory default setting. Refer to the instructions provided with the keypad for address setting procedure.
2. **Mount the keypads** at a height that is convenient for the user. Refer to the instructions provided with the keypad for mounting procedure.  
You can either surface mount or flush mount the 6139/6139R keypads using an appropriate Trim Ring Kit: 6139TRK - 6137/6137R keypads may *NOT* be flush mounted). Refer to the mounting instructions and template included with the keypad and/or trim ring kit for specific information.

### Preliminary Check-out Procedure

If you want to check that the system is working before connecting field wiring from zones and devices, do the following:

1. Temporarily connect a 2000 ohm end-of-line resistor across each of the hard-wire zones 1–5, as shown in the Summary of Connections diagram.  
Without actual zone wiring or EOL resistors connected, the keypads in the system will not display the "SYSTEM NORMAL" message.
2. Power up the system temporarily.
3. **Busy - Standby** (Alpha keypads) or **Not Ready** (Fixed-word keypads) will be displayed.

**After approximately 1 minute\***, the built-in green AC Power indicator should light, and the word AC (6137 or 6137R), or "SYSTEM NORMAL" (6139 or 6139R) should be displayed. \* To bypass the 1-minute delay, press # plus 0.

If keypads appear to be "dead" and are inoperable check that the keypads' address is set to "31" as described in the instructions provided with the keypad for address setting procedure.

If the "AC" or "SYSTEM NORMAL" display does not appear on any of the keypads in the system or a Zone Fault message is displayed, make sure each of the 5 basic hard-wired zones has a 2000 ohm resistor connected across its terminals.

4. When you get the proper "AC" or "SYSTEM NORMAL" message displayed on the keypad(s), the system is functioning properly at this point.

Do not remove the EOL resistors until you are ready to make connections to the hard-wired zones, to allow for testing later in the manual.



If an OC or OPEN CIRCUIT is present on the keypad, data from the control is not reaching the keypad. Please check the wiring (yellow data lead).

## Section 4. MECHANICS OF PROGRAMMING

This section provides the following information:

- How to enter and exit the programming mode
- How to program a data field
- How to review an entry in a data field
- How to erase an entry in a data field
- How to program user-friendly interactive modes (\*56, \*82)
- Loading factory defaults

### General Programming Information

Characteristics for each installation are stored in non-removable, electrically erasable, non-volatile EEROM memory. These must be programmed for the particular installation to establish its specific alarm and reporting features.

It is possible to program the system at any time, even at the installer's premises prior to the actual installation. Simply apply power temporarily to the control and then program the unit as desired.



There are two programming modes: data field programming and interactive (menu) mode programming. Data field programming is used for setting various system options and interactive programming is used for programming zone information.



To program the system, you must use a 6139 or 6139R Alpha keypad connected to keypad terminals on the control (17, 18, 19, and 20). The Alpha keypad need not necessarily remain in the system after programming.

Programming can also be performed remotely from the installer's office/home, using an IBM (or compatible) personal computer (or laptop), a Hayes modem, and V-Link downloading software. See the *REMOTE PROGRAMMING AND CONTROL (DOWNLOADING)* section for details.

### Entering Program Mode

You may use one of the following methods:

- a) Press both the [\*] and [#] keys at the same time **within 50 seconds after power is applied to the control, or**
- b) After power up, enter the Master code (5 1 1 0) + 8 0

This method is disabled if you exit the program mode using \*98 instead of \*99. See "Exiting Program Mode" paragraph later in this section.

If a different Master code is subsequently programmed, use it instead of 5110 to gain access to the programming mode.

Following entry into program mode, the built-in indicators will simultaneously flash and the alpha keypad will display field \*20 (this is the first field in the system). The system will now accept entries for field \*20.



***Before programming data fields for the first time, enter \*97 to load factory defaults! Then press \*96 if downloading is to be performed.***

### Programming a Data Field

1. Press [\*] plus **Field No.** (for example, \*20), then make the required entry.
2. When you have completely programmed a data field, the keypad will "beep" three times and then automatically display the next data field in sequence. To go to a different field, press [\*] plus the desired field no..
3. If the number of digits that you need to enter in a data field is less than the maximum digits available (for example, the phone number field), enter the

desired data, then press [\*] plus the next data field number to be programmed.

- 4. If you try to enter a non-existent field, the keypad will display **EE or Entry Error**. Simply re-enter [\*] plus a valid field number.

**Reviewing a Data Field**

Press [#] plus **Field No.** Data will be displayed for that field number. **No changes will be accepted in this mode.**

**Erasing an Entry in a Data Field**

To delete an entry in a field, press [\*] plus **Field No. + [\*]**. (Applies only to fields \*40-\*43, and \*94).

**Interactive Mode Programming (\*56 and \*82)**

Typical prompt displayed during interactive mode programming

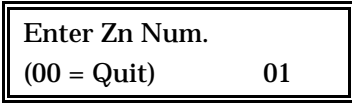

Zone Number ↑

Press [\*] plus **interactive mode No.** (for example, \*56). The Alpha keypad will display the first of a series of prompts requesting entries.

A detailed procedure (with displays of prompts) is provided in those sections where programming in the interactive mode is to be performed.

<b>Interactive Mode</b>	<b>Used To Program</b>
*56 Zone Programming	Zone characteristics and report codes
*82 Alpha Programming	Zone alpha descriptors

**Loading Factory Defaults**

To load the factory defaults, enter the programming mode, press \*97



**\*96** resets the Subscriber Account number and CSID in preparation for an initial download. If using \*96, it must be done after \*97 if loading factory defaults.

**Exiting the Programming Mode**

**\*99** allows re-entry into the program mode using **Master Code + 8 0**.

**\*98** inhibits re-entry into the programming mode using the Master code.

## Section 5. BASIC HARD-WIRED ZONES 1-5

This section provides the following information:

- General information about hardwired zones
- Installing 2-wire smoke detectors
- Installing 4-wire smoke/combustion detectors
- Programming hardwired zones
- Checkout procedure for hardwired zones

### General Information about Hardwired Zones

Provides 5 Style B supervised hardwired zones having the following characteristics:

- EOLR supervision supporting N.O./N.C. contacts from a listed fire alarm control panel or N.O./N.C. sensors, including:
  - fire alarm sensors (N.O. only)
  - 24-hr. alarm sensors
  - fire sprinkler supervisory sensors
- 300 – 500ms response time
- Individually assignable to bell output and/or aux. relay
- Supports up to 16 2-wire smoke detectors on Zone 5
- Supports 4-wire smoke detectors on any zone (power to these should be supplied from the control's aux. relay power output; see "Installing 4-Wire Smoke Detectors" later in this section).
- Tolerance of 300-ohms on Zones 1-4, 100-ohms on Zone 5 (excluding EOLR)

### Wiring Devices To Zones 1-5

1. When used as a slave DACT for a listed FACP, wire the FACP's alarm, supervisory and trouble contacts to the 5110XM's hardwired zones (terminals 9-16). Fire alarm initiating devices such as smoke detectors should be wired to the FACP and not the 5110Xm. When used as a stand alone control, wire alarm initiating devices to the 5110Xm's hardwired zones. See the summary of connections diagram.
2. Connect closed circuit devices in series in the high (+) side the loop. The 2,000 ohm EOL resistor must be connected in series with the devices, following the last device. See the Summary of Connections diagram.
3. Connect open circuit devices in parallel across the loop. The 2,000 ohm EOL resistor must be connected across the loop wires *at the last device*.

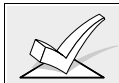

If the EOLR is not at the end of the loop, the zone will not be properly supervised, and the system may not respond to an open circuit on the zone.

### Wiring 4-Wire Smoke/Combustion Detectors on Zones 1-5

The system will support as many 4-wire detectors as can be powered from Auxiliary Relay Power on the control. Refer to the detector's instructions for complete details regarding its proper installation and operation.

1. Connect 12 volt power for the detectors from Auxiliary Relay Power terminals **7 (+)** and **18 (-)**. Be sure to program the Aux Power Relay for the smoke detector reset function in program field \*34. Observe proper polarity when connecting detectors.
2. Connect detectors (including heat detectors, if used) across zone terminals. All detectors must be wired in parallel with the 2,000 ohm resistor wired in parallel at the last device in the loop.



Remove 2000 ohm EOL resistor if connected across the zone terminals, and connect it across the loop wires at the last detector.

- To supervise power, you *MUST* use a UL listed End-Of-Line Power Supervision Relay (i.e. System Sensor No. A77-716B).

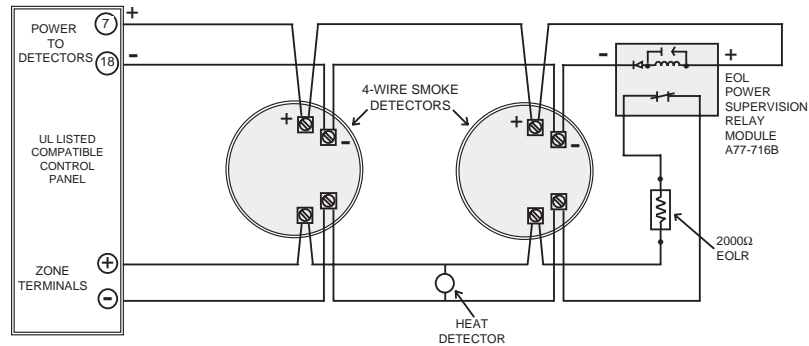

Four-Wire Detector Circuit

**Figure 4: 4-Wire Smoke Detector Connections**

COMPATIBLE 4-WIRE SMOKE/COMBUSTION DETECTORS	
<b>1412</b>	<i>System Sensor</i> , 4-wire ionization products of combustion detector
<b>2412</b>	<i>System Sensor</i> , 4-wire photoelectric smoke detector
<b>2412TH</b>	<i>System Sensor</i> , 4-wire photoelectric smoke detector w/135° F (57° C) heat detector
<b>2112/24T</b>	<i>System Sensor</i> low-profile 4-wire photoelectric smoke detector w/135° F (57° C) heat detector

#### Wiring 2-Wire Smoke Detectors To Zone 5

- Connect up to 16 of the 2-wire smoke detectors listed below across zone 5 terminals **15** (+) and **16** (-). Observe proper polarity when connecting the detectors.
- Connect the EOL resistor at the last detector.
- See “Programming Hard-Wired Zones” later in this section for a detailed programming procedure.



Due to the alarm current available on zone 5, only one smoke detector at a time can be supported in the alarmed state.

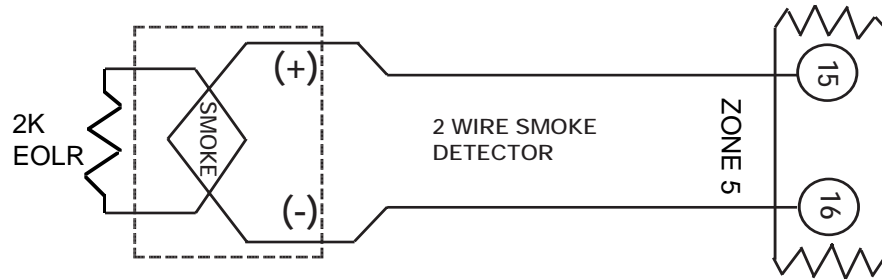

**Figure 5: 2-Wire Smoke Detector Connected to Zone 5**

<b>COMPATIBLE 2-WIRE SMOKE DETECTORS</b>	
<b>Detector Type</b>	<b>Device Model #</b>
Ionization, direct wire	System Sensor 1100
Ionization with B110LP base	System Sensor 1151
Ionization, direct wire	System Sensor 1400
Ionization w/B401B base	System Sensor 1451
Ionization duct detect. w/DH400 base	System Sensor 1451DH
Photoelectric, direct wire	System Sensor 2100
Photoelectric w/heat sensor, direct wire	System Sensor 2100T
Photoelectric w/B110LP base	System Sensor 2151
Photoelectric w/heat sensor, direct wire	System Sensor 2300T
Photoelectric, direct wire	System Sensor 2400
Photoelectric w/heat sensor, direct wire	System Sensor 2400TH
Photoelectric w/B401B base	System Sensor 2451
Photoelectric w/heat sensor & B401Bbase	System Sensor 2451TH
Photoelectric duct detector w/DH400 base	System Sensor 2451

Note: The above smoke detectors can be used together on zone 5.

**Fire Alarm Verification for Smoke Detectors**

This feature applies to 2-wire smoke detectors wired to zone 5 when zone 5 is set to response type 16. This feature also applies to 4-wire smoke detectors wired to any zone when the zone is set to response type 16 and the detectors are powered from the Aux relay power output (field \*34 must be set to 2).

The control will verify any alarm by resetting the smoke detectors after the first alarm trigger and then waiting 90 seconds for a second alarm trigger. If the smoke detector does not trigger again, the control will disregard the first trigger and no alarm signal will occur. This feature eliminates false alarms due to electrical or physical transients.

**Turning Off Fire Alarm Sounding**

You can turn off Fire alarm sounding by pressing the Silence/Reset key on the control's pc board or by entering the user's code + OFF [1] key on any keypad. To clear the "Alarm Silenced" message and to reset the detector's alarm, press the Silence/Reset key or enter the User's Code + OFF again.

## Programming Hard-Wired Zones

1. With at least one Alpha keypad (6139 or 6139R) connected to the keypad terminals on the control, power up the system temporarily.
2. Enter the programming mode by keying the following on the Alpha keypad:  
**Master code (5 1 1 0) + 8 0.**
3. **Press \*56.** Note that this is an interactive programming mode. You will use it to program zone numbers, zone types, and alarm report codes.

Enter Zn Num. (00 = Quit)                      01
--

Zone Number ↑

Typical summary display

Zn	ZT	RC
02	09	00

↓ Zone Number

02 Zone Type	
Fire	09

Zone Type ↑

Upon entering \*56 mode, this prompt will be displayed. Enter the first zone number that you wish to program (or [0][0] to exit zone programming). If you are starting with zone 2, enter "02". Press \* to continue.

A summary display will appear, showing the present status of that zone's programming.

**Zn** = zone number;

**ZT** = zone type;

**RC** = report code for that zone;

Values displayed are currently programmed values.

If the zone is programmed satisfactorily, press [#] to back up one step and enter the next zone number, if desired.

If you want to change a zone's programming, press [\*]. A prompt for Zone Type will appear.

Each zone must be assigned a zone type, which defines the way in which the system responds to faults in that zone. A detailed explanation of each zone type is provided in "Response Type Definitions" in the *ZONE RESPONSE TYPE DEFINITIONS* section.

Enter the desired zone type code, as listed below.

00 = Zone Not Used

06 = 24 Hr Silent

07 = 24 Hr Audible

08 = 24 Hr Aux

09 = Fire (NO verification.)

16 = Fire (Verification)\*

17 = Fire Waterflow

18. = Fire Supervisory

19. = 24 Hour Trouble

\*The "verification" feature is only active when zone type 16 is assigned to 2-wire smokes on zone 5 only or for 4-wire smokes on any zone that is powered from the Aux Power Relay.

Note: When used as a slave DACT for a listed FACP, use response type 09 for zones wired to FACP fire alarm, type 18 for supervisory, and type 19 for trouble contacts.

When the display shows the zone type you want, press [\*] to continue.



You must enter "00" as the **zone type** for any hard-wired zones that are not used.

02 Report Code		
1st 03	2nd 12	3C

The report code consists of 2 hexadecimal digits, each in turn consisting of 2 numerical digits. For example, for a report code of "3C", enter [0][3] for "3" and [1][2] for "C". Refer to *Section 11. SYSTEM COMMUNICATION* for complete information on report codes, if necessary.

Enter the desired report code and then press [\*] to continue.

Typical summary display

Zn	ZT	RC
02	09	3C

A summary display will appear, showing the data for the zone that was just programmed.

If it is programmed satisfactorily, press [\*] to continue.

Program Alpha?		
0 = No	1 = Yes	0

The next request is to enter Alpha descriptors for the zones. The entry may be done now (enter 1) or may be done at a later time using \*82 interactive mode (enter 0). We recommend that the entry of Alpha descriptors be done using \*82 mode.

Enter Zn Num.	
(00 = Quit)	02

If "0" (no) was entered above, the system will return to the "Enter Zone Number" prompt. Proceed with the programming for the next zone, as indicated previously.

When you have programmed all the detection zones satisfactorily, exit \*56 interactive mode at the **Enter Zn Num.** prompt by pressing: **[0] [0]**

Then exit the programming mode by keying \*99.

Proceed to the check-out procedure that follows.

**Check-Out Procedure For Detection Zones**

After installation of all devices is completed, the system should be checked, as follows.

1. Make certain that all devices and sensors connected to the zones are not in a faulted state.
2. Power up the control if you have not already done so..
3. After a 50 second delay, with all zones intact, the AC Power LED should be ON and the warning buzzer should be OFF. If an optional Alpha keypad is connected you should see the following display:

**** SYSTEM ****
**** NORMAL ****

If the warning buzzer is sounding or if the following is displayed on an optional Alpha keypad,

**Check xx Zone xx**

press the **silence/reset button** (located on the upper right-hand side of the 5110XM pc board) to silence the warning buzzer. Restore any open zone(s) as necessary (also make sure that you have connected a 2000 ohm EOL resistor across the terminals of unused zones); Press the silence/reset button again to reset the system and clear the display. If an optional Alpha keypad is installed, when the \*\*\*\* **SYSTEM NORMAL** \*\*\*\* message is displayed, you can proceed to the next step.

4. Fault and restore one of the hardwired zones. The built-in warning buzzer and optional remote keypad buzzer will provide a slow pulsing sound if a fire alarm was tripped, a steady sound if a 24 hour non-fire or emergency alarm was tripped, or a rapid pulsing sound if a fire supervisory or trouble condition was tripped.

Press the built-in Silence/Reset button to silence the buzzers. The built-in SILENCED LED will light. Press the Silence/Reset key again to clear the SILENCED indication. Repeat this procedure for each of the remaining hardwired zones.

**Note:** This test may activate external alarm sounders (if connected) and may send a central station report (if programmed). Therefore, building occupants and the central station should be alerted before conducting this test.

## Section 6. SYSTEM ZONES

This section provides the following information:

- General information about system zones
- System zone assignments

### General Information

System zones may be comprised of the following:

- Zones which monitor various device connections, as well as earth ground faults
- Keypad emergency zones, which may be assigned 24-hr. zone responses that are activated
- Zones which have a special purpose such as to bypass a relay, or to assign a zone descriptor to a relay

### System Zone Assignments

**Zone 6:** Bell Supervision – monitors the bell circuit output for open and short circuit faults. Defaults to zone response type 19 (24-Hr. Trouble) .

**Zone 7:** Keypad emergency – activated by pressing the keypad [B] key or by simultaneously pressing the[\*] and [#] keys. Keys must be held for two seconds.

**Zone 10:** Earth Ground Supervision – monitors the control's field wiring for earth ground faults. Defaults to zone response type 19 (24-Hr. Trouble). Supervision must be enabled (using response type 19) for fire installations.

**Zone 11:** Main Dialer Supervision – monitors the main dialer telephone connection for line faults. Defaults to zone response type 19 (24-Hr. Trouble).

**Zone 12:** Back-up Dialer Supervision – monitors the backup dialer telephone connection for line faults. Defaults to zone response type 19 (24-Hr. Trouble).

**Zone13:** Auxiliary Relay Disable – represents the auxiliary relay for purposes of allowing this relay to be bypassed. Does not supervise anything and does not get assigned a zone response type.

**Zone 95:** Keypad Emergency – activated by pressing the keypad [A] key or by simultaneously pressing the [1] and [\*] keys. Keys must be held for two seconds.

**Zone 96:** Keypad Emergency – activated by pressing the keypad [C] or by simultaneously pressing and holding the [3] and [#] keys for 2 seconds.

System zones are programmed through \*56 Zone Programming Mode.

The default values for these zones will meet the requirements for most installations.

## Section 7. ALARM INDICATING DEVICES

This section provides the following information:

- General information about the bell circuit output
- Connecting alarm indicating devices
- Examples of compatible alarm indicating devices
- Programming external sounder options

### General Information

The 5110XM provides one bell circuit output rated 12VDC nominal (10-14VDC), 1A max. which may be connected to 12V alarm indicating devices (horns, bells, sirens, etc.). This output may be configured for Style Y EOLR supervision or no supervision and is intended for use as a supervised fire alarm indicating circuit.



1. The bell output must be used for fire alarm annunciation when the 5110XM is used as a stand alone local control. Unless otherwise specified by the local AHJ, use of the bell output is not required for all other DACT and stand alone control installations. When used, the bell should be configured for supervision. 24 hour non-fire alarms (ex. type 07) must be programmed to activate the auxiliary relay output and not the bell output.
2. The total alarm current that can be drawn from the bell, auxiliary relay, and auxiliary power outputs combined must not exceed 1 amp.

The table below lists some examples of compatible polarized alarm sounding devices:

#### ***Compatible UL Listed Indicating Devices:***

<b>Model</b>	<b>Description</b>
<b>System Sensor PA400B (beige)/PA400R (red)</b>	Indoor piezo sounder rated at 90 dB @ 10 feet.
<b>System Sensor MA-12/24</b>	Horn
<b>System Sensor SS-12</b>	Strobe
<b>System Sensor SS1215 ADA</b>	Strobe
<b>System Sensor SS121575 ADA</b>	Strobe
<b>System Sensor MASS1215 ADA</b>	Horn/Strobe
<b>System Sensor SS121575 ADA</b>	Horn/Strobe
<b>System Sensor MA/SS-12</b>	Horn/Strobe
<b>Wheelock LS1-12-VFR</b>	Strobe
<b>Wheelock MS1-12-VFR</b>	Strobe
<b>Wheelock MT-12-LS-VFR</b>	Horn/Strobe
<b>Wheelock MT4-12-LS-VFR</b>	Horn/Strobe
<b>Wheelock MT-12-MS-VFR</b>	Horn/Strobe
<b>Wheelock MT4-12-MS-VFR</b>	Horn/Strobe
<b>Gentex GXS-2-15</b>	Strobe
<b>Gentex GXS-2-1575</b>	Strobe
<b>Gentex SHG-12-15</b>	Horn/Strobe
<b>Gentex SHG-12-1575</b>	Horn/Strobe
<b>Faraday 5336L-U-14-12-DC</b>	Horn/Strobe
<b>Faraday 5337L-U-14-12-DC</b>	Horn/Strobe

## Sounder Connections

Make connections to alarm output terminals 3 (+) and 4(-) (see Figure 6).

To supervise the bell wiring, do the following:

- Connect polarized 12V alarm indicating devices to the bell output terminals.
- Attach a 2K EOLR (model #610-7, supplied) across the bell wires at the last device on wire run.
- Program zone 6 for 24 hour trouble response (default setting).

When supervision is not desired, do the following:

- Cut the white jumper labeled W2 on control PC board.
- Program zone 6 for a "0" response type (not used).

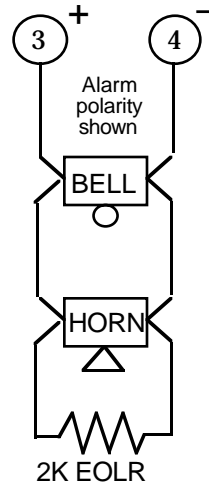

**Figure 6: Sounder Wiring**

## Programming for External Sounders

1. With at least one alpha keypad (6139 or 6139R) connected to the keypad terminals on the control, power up the system temporarily.
2. Enter the programming mode by keying the following on the alpha keypad:  
**Master code (5 1 1 0) + 8 0**

3. **Press \*30 (Alarm Bell Timeout)**

Enter [0] for NO TIMEOUT (default) [1] for 4 mins, [2] for 8 mins, [3] for 12 mins, or [4] for 16 mins. When used, the bell must be programmed to ring at least 5 minutes.

4. **Press \*76 (Waterflow Alarm Silencing)**

Enter [0] for MANUAL SILENCE only (default) or [1] for AUTOMATIC SILENCE when waterflow ceases (provided no other fire alarm is present). Note: the automatic silence option may only be used with the permission of the local AHJ.

5. **Press \*77 (Alarm Bell Sound)**

Enter [1] for Steady, [0] for Pulsing (default).

Note: The pulsing option causes bells to sound using NFPA three pulse temporal pattern.

6. **Press \*85 (Zones 1-7 Bell / Aux. Relay Activation)**

Enter [0] for NO ALARM ACTIVATION, [1] for BELL only, [2] for AUX. RELAY only, or [3] for BELL & AUX. RELAY. (default = [1] [1] [1] [1] [1] [1] [0] [0])

7. **Press \*86 (Zones 10-12, 95, and 96 Bell / Aux. Relay Activation)**

Enter [0] for NO ALARM ACTIVATION (\* *always enter [0] in the first space*), [1] for BELL only, [2] for AUX. RELAY only, or [3] for BELL & AUX. RELAY. (default = [0] [0] [0] [0] [0] [0])

**NOTE:** Zones programmed for fire alarm response (zone types 09, 16, or 17) *MUST* be programmed to activate the bell output (can trigger the aux relay additionally). Therefore, option 1 or 3 must be selected for fire zones.

8. Use \*56 to program system zone 6 as required.

9. Exit the programming mode by entering \*99.

### Testing the Sounder

After installation of the sounder is completed, the control should be carefully tested, as follows.

1. Apply AC power and connect the backup battery to the control's PC board.
2. Verify that all hard-wired zones are intact and that there are no system trouble conditions present. The keypads should display "system normal" (alpha) or "AC" (fixed word).
3. Perform the **FIRE DRILL TEST:**

This test activates the optional external alarm sounders, wired to the bell output on terminals 3 and 4, in a pulsing\* (or steady) manner, whichever was programmed in field \*77. This test may be performed only on systems that have an optional remote keypad and external fire alarm sounders installed. This test may be initiated with the master code or the user #2 code only (when no alarm, supervisory, or trouble conditions are present). The system remains operational for alarm signaling while this test is active.

\* **Pulsing** causes the bell to sound in the NFPA 3 pulse temporal pattern.

To initiate the FIRE DRILL test enter the master code (or the user # 2 code) + [#] [6] [9] on any remote keypad. The following will be displayed on an alpha keypad:

**Fire Drill Active**

\* or [TEST dF] on fixed-word keypads

To exit this test enter ANY user code + OFF.

# Section 8: AUXILIARY RELAY CONNECTIONS

This section provides the following information:

- General information about the auxiliary relay
- Wiring the auxiliary relay
- Programming the auxiliary relay

## General Information

The 5110XM provides on auxiliary relay output which may be configured as one of the following:

- Wet 12VDC form C relay output
- Dry, unsupervised form C relay output with contacts rated at 30VAC/VDC, 2A max. resistive loads

The relay (terminal 6) is set at the factory for a 12V nominal (10-14VDC) output, providing 350mA max standby current/1A max alarm current.

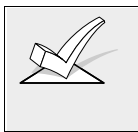

The total standby current that can be drawn from the auxiliary relay and auxiliary power outputs cannot exceed 350mA. The total alarm current that can be drawn from these outputs plus the bell output cannot exceed 1A.

If configuring the relay as a dry, form C relay output, cut the red jumper labeled W3 on the PC board. Zones programmed for non-fire related 24 hour audible alarm response (type 07) must be programmed to activate the auxiliary relay output and not the bell output.

## Relay Connections

The figures below show how to wire the auxiliary relay output for unsupervised alarm output and for 4-wire smoke detector power usage.

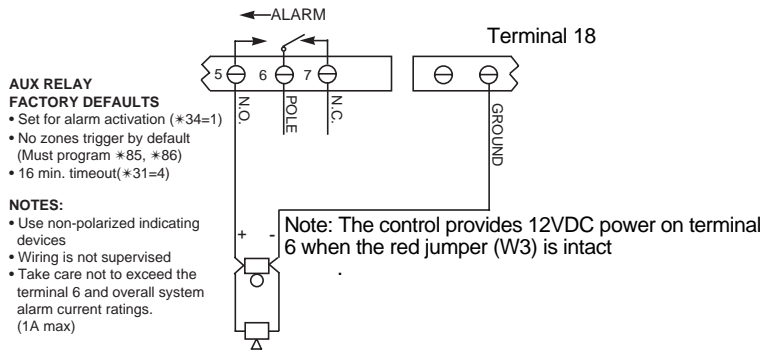

**Figure 7: Wiring the auxiliary relay output for unsupervised alarm output.**

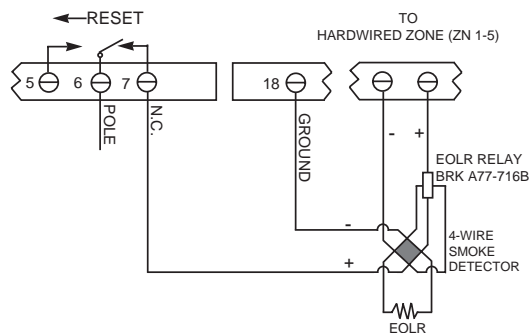

**Figure 8: Wiring the auxiliary relay output for 4-wire smoke detector power usage.**

## Programming the Auxiliary Relay

The auxiliary relay may be programmed for one of the following options:

- Trouble/Supervisory Activation
- Alarm Activation, silenced by [user code] + OFF
- 4-Wire Smoke Detector Reset
- Battery Saver
- Alarm Activation, silenced by [user code] + # 67

These options are described below:

- **Trouble/Supervisory Activation (\*34 = 0)** : Steady activation in response to any zone or system related trouble condition or to any fire supervisory condition. Remains activated until all fault conditions have been corrected and the Silence/Reset button has been pressed or the user code + OFF has been entered.
- **Alarm Activation, silenced by [user code] + OFF (\*34 = 1)**: Steady activation in response to an alarm on one, some or all zones, as selected in fields \*85 and \*86. If selected, the auxiliary relay remains activated until Aux. Relay Timeout (\*31) or until the Silence/Reset button has been pressed or until the User Code + OFF has been entered.
- **4-Wire Smoke Detector Reset (\*34 = 2)**: Momentary (6 second) activation at second entry of user code + OFF sequence which interrupts power to 4-wire smoke detectors connected to hard-wired zones (zones 1-5), allowing the detectors to be reset following an alarm. Power to 4-wire smoke detectors should be wired to the auxiliary relay as shown above.
- **Battery Saver Option (\*34 = 3)**: When this function is selected, the auxiliary relay will normally be activated (i.e. N.O. and pole contacts will be connected, N.C. contact will be open) and will de-activate 4 hours after the start of an AC power failure. Using this feature, non-critical loads (such as supplementary keypads) which do not need to be supported for the full 24 hour battery backup period can be disconnected from the auxiliary outputs, allowing a smaller capacity battery to be used. The relay re-activates within a few seconds after AC power restores.
- **Alarm Activation, silenced by [user code] + #67 (\*34 = 4)**: Steady activation in response to an alarm on one, some or all zones, as selected in fields \*85 and \*86. If selected, the auxiliary relay remains activated until the User Code + #67 has been entered.

When this function is used, the auxiliary relay can be used for elevator recall or ventilator shutdown on fire alarms.

## Section 9. FINAL POWER UP

This section provides the following information:

- Connecting the AC transformer
- Making earth ground connections
- Applying power to the control
- Installing the backup battery
- Backup battery calculations

In Section 2, you made temporary power connections for the purpose of programming and testing the installation. This section provides information about final power-up procedures and battery size calculations.

### AC Power Connections

The 5110XM has a built-in, enclosed AC power transformer with manually resettable circuit breaker protection, located in the lower lefthand corner of the control's cabinet.

**UL**

1. A dedicated 120VAC circuit must be used for fire applications.
2. Wires must be rated for 90 degrees C or higher operation.

Follow the steps below to make AC power connections.

1. Remove the cover from the transformer's enclosure.
2. Remove the lower knockout on the lefthand side of the cabinet. Run 120VAC power wires into the transformer enclosure via this knockout.



***Make sure that the dedicated AC circuit is not powered at this time.*** Apply AC power only after all other wiring, except the backup battery wiring, has been completed.

3. Use wire nuts (not supplied) to splice the 120VAC wires to the transformer's black and white flying leads. Push the mated wires back into the transformer enclosure.
4. Connect the transformer's 18VAC BLUE flying leads which emerge from the top of the enclosure to the 5110XM's AC terminals (Terminals 1 and 2).
5. Make earth ground connections as specified below.

### Earth Ground Connections



The 5110XM requires connection to a good earth ground in order to provide proper 120VAC shock hazard protection, lightning transient protection, and earth ground fault detection.

Refer to the National Electrical Code for proper earth grounding methods.

To make earth ground connections, do the following:

1. Run an earth ground wire into the transformer enclosure via the same knockout used for 120VAC wiring.

2. Use a wire nut (not supplied) to splice this earth ground wire to the green flying lead located inside of and bonded to the transformer enclosure. Push the mated wires into the enclosure.
3. Connect the green flying lead which emerges from the top of the transformer enclosure to the 5110XM's earth ground terminal (Terminal 8).
4. Replace the transformer enclosure cover after wiring is complete.

### **Powering Up the System**

Apply AC power to the control. Following power-up, **Busy-Standby** (alpha keypads) or **NOT READY** (fixed-word keypads) will be displayed.

After approximately 1 minute, the initial displays will revert to **SYSTEM NORMAL** for alpha keypads, or **AC** for fixed-word keypads (if there are no faulted zones).

**To bypass this delay, press: [#] + [0].**

### **Connecting The Back-Up Battery**

In the event of an AC power loss, the control must be supported by a back-up, rechargeable 12V, 7AH min/14AH max sealed lead acid (gel cell type) battery.

The battery's capacity must be sized to provide 24 hours (UL Central Station Fire) or 60 hours (UL Remote Station Fire) of standby time followed by 5 minutes of alarm time. Use the steps below to calculate the required battery capacity.

### **Calculating the Battery Size Needed**

Use the worksheets below to determine the total standby and alarm loads and the required battery capacity. Then select a battery having a capacity greater than or equal to the calculated capacity.

**TOTAL STANDBY/ALARM LOAD WORKSHEETS**

To calculate the total current for the Aux. power, bell & aux. relay outputs, multiply each device's standby and/or alarm current by the number of units used.

- 1) Enter devices used on aux. power output, calculate standby and alarm currents, then add to get aux. power current subtotal.

AUX. POWER OUTPUT				Total Current	
Device Model #	Device Current	X # of Units	=	Standby	Alarm
<b>Aux. Power Output Subtotal</b> (terminals 17 & 18)				350mA max	350mA max

Note: 6137/6137R Draws 85mA during alarm and 40mA during battery standby  
6139/6139R Draws 100mA during alarm and 40mA during battery standby

- 2) Enter devices connected to bell output, calculate alarm currents, then add to get bell output current subtotal.

BELL OUTPUT				Total Current	
Device Model #	Device Current	X # of Units	=	Standby	Alarm
				XXXXXX	
				XXXXXX	
				XXXXXX	
				XXXXXX	
				XXXXXX	
Bell Output Subtotal				XXXXXX	(1.0 Amp max)

- 3) Enter devices connected to the aux. relay output, calculate standby and alarm currents, then add to get aux. relay output current subtotal.

Note: No entries are necessary when the red relay power jumper (W3) is cut.

AUX. RELAY OUTPUT				Total Current	
Device Model #	Device Current	X # of Units	=	Standby	Alarm
Aux. Relay Output Subtotal (terminals 5, 6 or 7 & 18) max)				(350 mA max)	(1.0 Amp)

4) Enter the calculated subtotals of all listed outputs then add to get combined current.

COMBINED AUX. POWER, BELL AND RELAY OUTPUT	Total Current	
	Standby	Alarm
Aux. Power Output Subtotal		
Bell Output Subtotal	XXXXX	
Aux. Relay Output Subtotal		
Add all subtotals (Cannot exceed 350mA max. standby; 1.0 amp max. alarm)		

5) These values are fixed.

5110XM PCB CURRENT	Total Current	
	Standby	Alarm
Includes 2-wire smoke detector and LED indicator PCB currents	155mA	235mA

6) Enter the calculated combined currents then add to total PCB current.

TOTAL CONTROL LOAD	Total Current	
	Standby	Alarm
Combined aux. power, bell and aux. relay output current		
Total PCB current	155mA	235mA
Total power supply load*		

\* Limit the total power supply standby current to 210 mA when a 60 hr. standby time is desired.

7) Using the total calculated power supply load (step 6), calculate the battery capacity required for the installation.

**BATTERY CAPACITY CALCULATION WORKSHEET**  
(For 24 or 60 hour standby followed by 5 minute fire alarm)

Capacity	Formula	Calc Value
Standby Capacity	total standby load X 24 or 60 hours X 1.1 contingency factor (use total standby load from previous worksheet)	
Alarm Capacity	total alarm load X 0.083 hours (5 minutes) (use total alarm load from previous worksheet)	
Total Capacity	Add standby and alarm capacities (14AH max)	

8) Using the battery capacity from step 7, select the appropriate battery.

**BATTERY SELECTION TABLE**

7 AH	Yuasa NP7-12
14 AH	Yuasa NP7-12 (connect 2 in parallel, mounted vertically in cabinet)

**Making the Battery Connections**

1. Use the battery capacity calculation worksheet(above) to determine the appropriate battery for the installation.



Do not connect the batteries until all devices have been wired to the control.

2. Verify that the proper float charging voltage (13.5–13.8VDC) is present across the battery terminals of the 5110XM PCB. If not, check that the auxiliary power and auxiliary relay outputs are not loaded in excess of their ratings.

3. If two batteries are required, connect them in parallel using the dual battery harness. Both batteries should be mounted as shown in the figure below to ensure that neither battery's terminals can be shorted.

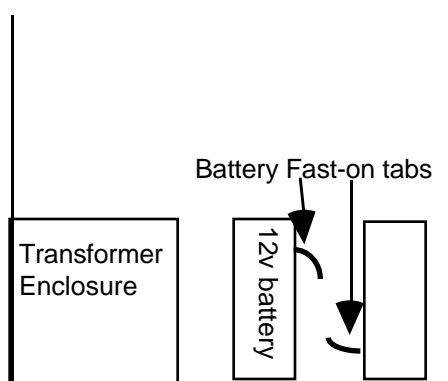

Note: When connecting batteries in parallel:

- Use batteries from the same manufacturer and with the same voltage and capacity rating.
- Use batteries with approximately the same age and state of charge.
- Use cables provided and observe polarity.

It is recommended that all batteries be replaced at the same time, even if only one battery has become weak.

4. Attach the Red and Black wires on the battery connector as follows:
  - a) Red to the positive (+) battery tab on the control board.
  - b) Black to the negative (-) battery tab on the control board.(See the SUMMARY OF CONNECTIONS diagram for location of the (+) and (-) battery tabs on the control board.)
5. Attach the Red and Black wires at the other end of the battery connector cable as follows:
  - a) Red to the positive (+) terminal on the battery.
  - b) Black to the negative (-) terminal on the battery.

### **Battery Supervision**

The 5110XM runs a brief battery test once a minute to determine if battery leads are connected and runs an extended battery test every 24 hours to determine if battery capacity is low (less than approximately 11.5VDC). If a low battery condition exists the 5110XM's built-in Battery Trouble LED will light and a rapid beeping sound will be heard from its built-in warning buzzer. In addition, if a keypad is on the system, it will be displayed at the control's keypad(s). These indications will stop when the low battery condition has been restored to normal (for several minutes). Refer to the *TESTING THE SYSTEM* section for additional battery test information.

# Section 10.

## ALPHA DESCRIPTOR PROGRAMMING

This section provides instructions for programming alpha descriptors, which is recommended for systems using alpha keypads.

The ALPHA VOCABULARY LIST and CHARACTER CHART are found later in this section.

### Assigning Zone Descriptors

The alpha keypad used with the 5110XM can have a user-friendly English language description/location of all protection zones and keypad emergency zones programmed into the system. Each description can be composed of a combination of words (up to a maximum of 3) selected from a vocabulary of 249 words stored in memory (listed later in this section). In addition, up to 5 installer-defined words can be added to those already in memory. Thus, when an alarm or trouble occurs in a zone, an appropriate description for that zone's location will be displayed at the keypad.

**Note:** Alpha descriptor entry can be done locally at the alpha keypad or remotely using downloading software. The alpha keypad procedure is described below.

### Entering Zone Descriptors (program menu mode \*82)

The descriptor can be entered when the zone is being defined in field \*56 but we recommend that it be done in field \*82.

There are two methods that can be used to enter alpha descriptors.

The easiest method requires that you simply enter the 3-digit reference number for the desired word(s). The 3-digit number for each word is provided in the alpha vocabulary list (on a following page).

An alternate method allows you to pick the desired words by scrolling through the alpha vocabulary list.

### Programming the Descriptors

1. With the system powered up, enter the programming mode by keying:

**Master code (5 1 1 0) + 8 + 0 .** The following display will appear:

Master Code	20
-------------	----

Program Alpha ?	
0 = No, 1 = Yes	00

2. **Press \*82.**

The "Program Alpha ?" prompt will appear.

Custom Words ?	
0 = No, 1 = Yes	00

3. **Press "1" (Yes).**

The "Custom Words" prompt will appear.

*Summary Mode Display*

Default Descriptor [

S ZN 01 ZONE 01

Flashing Cursor (system is ready for entry of word).

S ZN 01 A

Flashing Cursor [

S ZN 01 B ACK

S ZN 01 BACK  
A

+  
Flashing Cursor if "6" is pressed (system is ready for next word).

S ZN 01 BACK  
D OOR

+Flashing Cursor

4. **Press "0" (No).**\* The system will then automatically display the descriptor for zone 1.

\* The procedure for adding custom words to the built-in vocabulary will be found later under "Adding Custom Words".

If a descriptor was not entered previously for zone 1, the default descriptor for zone 1 will be displayed.

Note that this a "summary mode", and that no entries can be made. Entries can be made only when the display contains a flashing cursor, which signifies the "entry mode".

5. To delete or change the default descriptor for zone 1, **press \* plus the same zone number (01)**. This will clear that descriptor and gain access to the entry mode with flashing cursor, allowing changes to be made.

NOTE: If you do not wish to change the existing descriptor for zone 1, enter \* plus the next zone number for which you wish to enter (or check) a descriptor. A summary display for that zone will appear. You must then press \* plus the same zone number again to gain access to the entry mode (flashing cursor) for that zone.

6. **Press # plus 3-digit number** for the first word from the "Alpha Vocabulary List". Example: The descriptor that we wish to enter for zone 1 is BACK DOOR. From the list, BACK = 015. Therefore, you would enter # 0 1 5.

**Note:** If you accidentally enter the wrong word, simply press # plus the correct 3-digit number for the word you want.

7. **Press "6" to accept the selected word and continue.**

**Note:** If this is the only word you are using for the descriptor, press "8" instead of "6" to save that word in memory, and then go to step 11.

8. **Enter the 3-digit number for the next word.** In our example, the word is DOOR, whose number is "061".

Enter # 0 6 1. This display will appear:

```
S ZN 01  BACK
DOOR  A
```

+  
Flashing Cursor if "6" is pressed (system ready for next word).

#### Summary Display

```
S ZN 01  BACK
DOOR
```

```
Program Alpha ?
0 = No, 1 = Yes  00
```

```
Alpha Pgm
82
```

9. Press "6" to accept the selected word.

**Note:** If these are the only words you are using for the descriptor, press "8" instead of "6" to save them in memory.

10. The two words in our example have now been entered. Note, however, that up to three words may be entered (provided the number of characters will fit on the screen). Press "8" to save all words in memory.

The "A" with the flashing cursor over it will disappear, indicating that the word(s) are stored in memory for that zone, as shown in the summary display at the left.

11. To enter a descriptor for the next zone, press \* plus the desired zone number (e.g., \*02. The summary display following step 4 previously will appear. Now repeat steps 5 through 10 for the descriptor for the next zone.

12. To exit the Alpha descriptor mode, press "+0+0" at the summary display. This prompt will be displayed.

13. Press "0". This will be displayed.

14. Press \*99 to exit the programming mode.

### Alternate Method For Programming Zone Descriptors

#### When entering Zone Descriptors using Method 2, the keypad keys perform the following functions:

- [3] Scrolls both alphabet and actual words in *ascending* alphabetical order.
- [1] Scrolls both alphabet and actual words in *descending* alphabetical order.
- [6] Selects between alphabet and actual word list; also used to save words.
- [8] Stores the zone description in memory.

1. Perform steps 1 through 5 of previous method.
2. Note that the first letter of the alphabet appears after the zone number, and that the zone number is automatically included with the description. *If there already is a description for the zone*, the description will appear (with no cursor, since this is a display mode). *To enter or change a description*, press [\*] + Zone Number again. A flashing cursor will now appear. Assume, for example, that the desired description for zone 1 is BACK DOOR.
3. **Select the first letter of the desired description** (note that "A" is already displayed). Press key [3] repeatedly to advance through the alphabet (e.g., to "B"), or key [1] to go backward. Then press [6] to display the first available word beginning with the desired letter (e.g., BABY). Next, press [3] repeatedly to move forward, or [1] to move backward, until the desired word is displayed (e.g., BACK). Then press [6] to accept the word and toggle back to the alphabet list.

4. For selection of the next word (e.g., DOOR), repeat step 3, as follows.  
Press key [3] until the first letter of the next word appears (e.g., "D"). Then press [6] to display the first available word beginning with that letter (e.g. DAUGHTERS). Press [3] repeatedly until the desired word (e.g., DOOR) appears. To accept the word, press [6], which toggles back to the alphabet list.
5. When all desired words have been entered, press [8] to store the description in memory.
6. Enter \*NN, where NN is the next zone that you want to review or for which you want to program a descriptor. To modify the descriptor, enter \*NN again. To exit this mode, press "\*00".

### Adding Custom Words

You can add up to five installer-defined words to the built-in vocabulary. Each of the five "words" can actually consist of a "word string" of one or more words, but no more than *ten* characters can be used for each word or word string.



Custom words must begin with an *alphabetic* character. If a number or symbol is used as the first character, the word will not be saved.

**When adding Custom Words in steps 3-6, the keypad keys perform the following functions:**

- [3] Advances through the alphabet in ascending order.
- [1] Moves through the alphabet in descending order.
- [6] Selects desired letter; moves cursor one space to right.
- [4] Moves cursor one space to left.
- [7] Inserts a space at the cursor location, erasing any character located there.
- [8] Saves the new word in the system's memory.

1. Perform steps 1, 2, and 3 of **Programming the Descriptors** on a previous page.  
Select CUSTOM WORD mode (enter "1") when the prompt **CUSTOM WORD ?** is displayed.
2. Enter the number ([1]–[5]) of the custom word or word string to be created (for example, if you are creating the *first* custom word or word-string, enter [1], for the *second*, enter [2], etc.). A cursor will now appear at the beginning of the second line.
3. **One of two methods of entering the custom word's characters can now be used** (refer to the *CHARACTER LIST* of letters, numbers, and symbols on a following page):
  - Method 1:**  
Press the [#] key, followed by the two-digit entry for the first letter you would like to display (e.g., [6][5] for "A"), **or...**
  - Method 2:**  
Use the [3] key to advance through the list of symbols, numbers, and letters. Use the [1] key to move back through the list.
4. When you have reached the desired character, press [6] to select it. The cursor will then move to the right, in position for the next character.
5. Repeat steps 3 and 4 to create the desired word(s). Note that the [4] key can be used to move the cursor to the left, if necessary, and that key [7] can be used to enter a blank (or erase an existing character). Remember, no word or word-string can exceed 10 characters.
6. Press the [8] key to save the custom word(s) and return to the "**CUSTOM WORD ?**" display.  
Repeat steps 2–5 for other custom words to be entered. To change a custom word, just overwrite it. If no more are to be entered now, press [0] to return to the Descriptor entry. The custom word(s) will be automatically added to the built-in vocabulary.

When zone descriptors are being entered as described in step 6 of **Programming the Descriptors**, the custom word numbers are 250 to 254 for words 1 to 5 respectively.

When being entered as described in step 3 in **Alternate Method For Programming Zone Descriptors**, each word will be found at the end of the group of words that begin with the same letter as it does.

# ALPHA VOCABULARY LIST

(For Entering Zone Descriptors)

000 (Word Space)					
<b>A</b>	058	<b>K</b>	<b>R</b>	<b>V</b>	
001 AIR	DISCRIMINATOR	111 KITCHEN	161 RADIO	214 VALVE	
002 ALARM	059 DISPLAY		162 REAR	215 VAULT	
003 ALCOVE	060 DOCK	112 LAUNDRY	163 RECREATION	216 VIBRATION	
004 ALLEY	061 DOOR	113 LEFT	164 REFRIG	217 VOLTAGE	
005 AMBUSH	062 DORMER	114 LEVEL	165 REFRIGERATION	<b>W</b>	
006 ANTENNA	063 DOWN	115 LIBRARY	166 RELAY	218 WALL	
007 AREA	064 DOWNSTAIRS	116 LIGHT	167 RF	219 WAREHOUSE	
008 APARTMENT	065 DRAWER	117 LINE	168 RIGHT	220 WASH	
009 ART	066 DRIVEWAY	118 LIQUOR	169 ROOM	221 WEST	
010 ATTIC	067 DRUG	119 LIVING	170 ROOF	222 WINDOW	
011 AUDIO	068 DUCT	120 LOADING	<b>S</b>	223 WINE	
012 AUX		121 LOCK	171 SAFE	224 WING	
013 AUXILIARY	069 EARTH	122 LOOP	172 SCREEN	225 WIRELESS	
	070 EAST	123 LORRA	173 SENSOR	226 WORK	
<b>B</b>	071 ELECTRIC	124 LOW	174 SERVICE	<b>X</b>	
014 BABY	072 EMERGENCY	125 LOWER	175 SHED	227 XMITTER	
015 BACK	072 ENTRY	<b>M</b>	176 SHOCK	<b>Y</b>	
016 BACKUP	074 EQUIPMENT	126 MACHINE	177 SHOP	228 YARD	
017 BAR	075 EXECUTIVE	127 MAGNETIC	178 SHORT	<b>Z</b>	
018 BARN	076 EXIT	128 MAIDS	179 SHOW	229 ZONE (No.)	
019 BASEMENT	077 EXTERIOR	129 MAIN	180 SIDE	230 ZONE	
020 BATHROOM	<b>F</b>	130 MASTER	181 SKYLIGHT		
021 BED	078 FACTORY	131 MAT	182 SLIDING		
022 BEDROOM	079 FAILURE	132 MEDICAL	183 SMOKE	231 0	
023 BELL	080 FAMILY	133 MEDICINE	184 SONIC	232 1	
024 BLOWER	081 FATHERS	134 MICROWAVE	185 SONS	233 1ST	
025 BOILER	082 FENCE	135 MONEY	186 SOUTH	234 2	
026 BOTTOM	083 FILE	136 MONITOR	187 SPRINKLER	235 2ND	
027 BOX	084 FIRE	137 MOTHERS	188 STATION	236 3	
028 BREAK	085 FLOOR	138 MOTION	189 STEREO	237 3RD	
029 BUILDING	086 FLOW	139 MOTOR	190 STORE	238 4	
030 BURNER	087 FOIL		191 STORAGE	239 4TH	
	088 FOYER	<b>N</b>	192 STORY	240 5	
031 CABINET	089 FREEZER	140 NORTH	193 STRIKE	241 5TH	
032 CALL	090 FRONT	141 NURSERY	194 SUMP	242 6	
033 CAMERA	091 FUR	<b>O</b>	195 SUPERVISED	243 6TH	
034 CAR	092 FURNACE	142 OFFICE	196 SUPERVISION	244 7	
035 CASE		143 OIL	197 SWIMMING	245 7TH	
036 CASH	093 GALLERY	144 OPEN	198 SWITCH	246 8	
037 CCTV	094 GARAGE	145 OPENING	<b>T</b>	247 8TH	
038 CEILING	095 GAS	146 OUTSIDE	199 TAMPER	248 9	
039 CELLAR	096 GATE	147 OVERFLOW	200 TAPE	249 9TH	
040 CENTRAL	097 GLASS	148 OVERHEAD	201 TELCO		
041 CIRCUIT	098 GROUND	<b>P</b>	202 TELEPHONE	250 Custom Word #1	
042 CLIP	099 GUEST	149 PAINTING	203 TELLER		
043 CLOSED	100 GUN	150 PANIC	204 TEMPERATURE		
044 COIN		151 PASSIVE	205 THERMOSTAT	251 Custom Word #2	
045 COLD	101 HALL	152 PATIO	206 TOOL		
046 COATROOM	102 HEAT	153 PERIMETER	207 TRANSMITTER		
047 COLLECTION	103 HIGH	154 PHONE	208 TRAP	252 Custom Word #3	
048 COMBUSTION	104 HOLDUP	155 PHOTO	209 TRIGGERS		
049 COMPUTER	105 HOUSE	156 POINT	<b>U</b>	253 Custom Word #4	
050 CONTACT		157 POLICE	210 UP		
	<b>I</b>	158 POOL	211 UPPER		
051 DAUGHTERS	106 INFRARED	159 POWER	212 UPSTAIRS	254 Custom Word #5	
052 DELAYED	107 INSIDE	<b>Q</b>	213 UTILITY		
053 DEN	108 INTERIOR	160 QUAD			
054 DESK	109 INTRUSION				
055 DETECTOR	<b>J</b>				
056 DIALER	110 JEWELRY				
057 DINING					

## CHARACTER (ASCII) CHART (For Adding Custom Words)

32 (space)	51 3	71 G
33 !	52 4	72 H
34 "	53 5	73 I
35 #	54 6	74 J
36 \$	55 7	75 K
37 %	56 8	76 L
38 &	57 9	77 M
39 '	58 :	78 N
40 (	59 ;	79 O
41 )	60 <	80 P
42 *	61 =	81 Q
43 +	62 >	82 R
44 ,	63 ?	83 S
45 -	64 @	84 T
46 .	65 A	85 U
47 /	66 B	86 V
48 0	67 C	87 W
49 1	68 D	88 X
	69 E	89 Y
	70 F	90 Z

# Section 11. SYSTEM COMMUNICATION

This section provides the following information:

- General information about system communication
- An explanation of report formats
- Programming communications options

## General Information

The process of a successful transmission consists of both the method of communication between the control and the central station receiver and the actual way the information is sent and displayed at the central station.

When the control calls the central station receiver, it waits to hear a “handshake” frequency from the receiver to confirm that the receiver is on-line and ready to receive its message. Once the control hears the handshake it is programmed to listen for, it sends its message. The control then waits for a “kissoff” frequency from the receiver acknowledging that the message was received and understood.

If the handshake frequency is not given or is not understood by the control, the control will not send its message. Once the handshake frequency is received and understood by the control, the control will send its message. If there is an error in the transmission (the receiver does not receive a “valid” message), the kissoff frequency will not be given by the central station receiver.

The 5110XM has two dialers – a main and a back-up dialer. Each of these is enabled separately in program field \*79 (both are enabled by default). If enabled, the back-up dialer will only become active when a line fault (voltage on the main dialer drops below 2 volts) is sensed. The main and back-up dialers are supervised by system zones 11 and 12, respectively.

The control will make up to ten attempts to get a valid message through. (Ten attempts will be made to the primary number when only this number is programmed, and five attempts will be made to the primary number followed by five attempts to the secondary number when both numbers are programmed). If the control is not successful after its numerous attempts, the **Comm Fail** LED will light. (If an optional keypad is installed it will display “Communication Failure” (alpha keypad) or “FC” (fixed-word keypad)).

Regardless of the format chosen the 5110XM will transmit reports in the following priority order:

1. Alarms (Fire and emergency)
2. Fire Supervisories and Troubles
3. All remaining reports

## Report Code Formats

The following chart defines the three sets of (handshake/kissoff) frequencies that the control supports and the different formats that can be sent for each.

FORMAT	HANDSHAKE	TRANSMITS DATA	KISSOFF	TRANSMIT TIME
Low Speed 3+1 4+1 4+2	1400Hz	1900Hz (10PPS)	1400Hz	Under 15 secs. (Standard report)
Sescoa/Rad 3+1 4+1 4+2	2300Hz	1800Hz (20PPS)	2300Hz	Under 10 secs. (Standard report)
Express 4+2	1400-2300Hz	DTMF (10 cps)	1400Hz	Under 3 secs.
Contact ID	1400-2300Hz	DTMF (10 cps)	1400Hz	Under 3 secs.

**The following describes each format in greater detail.**

<b>3+1 and 4+1 Standard Formats</b>	Comprise a 3- (or 4-) digit subscriber number and a single digit report code (e.g. Alarm, Trouble, Restore, etc.).
<b>3+1 and 4+1 Expanded Formats</b>	Comprise a 3- (or 4-) digit subscriber number, and a two-digit report code. The first digit is displayed on the first line, followed by a second line where the first digit is repeated 3 (or 4) times and followed by the second digit. This is the “expanded” digit.
<b>4+2 Format</b>	Comprises a 4-digit subscriber number and 2-digit report code.
<b>Ademco Contact ID Reporting Format</b>	Comprises a 4-digit subscriber number, 1-digit event qualifier ("new" or "restore"), 3-digit event code, and 3-digit zone number, or system status number (see the following page).

<b>Report</b>	<b>3+1/4+1 Standard</b>	<b>3+1/4+1 Expanded</b>	<b>4+2</b>
Alarm	SSS(S) A	SSS(S) A AAA(A) Z	SSSS AZ
Trouble	SSS(S) T	SSS(S) T TTT(T) t	SSSS Tt
Supervisory	SSS(S) Sp	SSS(S) Sp SpSpSp(Sp) Sp2	SSSS SpSp2
Bypass	SSS(S) B	SSS(S) B BBB(B) b	SSSS Bb
AC Loss	SSS(S) E	SSS(S) E EEE(E) Ac	SSSS EA <sub>C</sub>
Low Batt	SSS(S) L	SSS(S) L LLL(L) L <sub>B</sub>	SSSS LL <sub>B</sub>
Test	SSS(S) G	SSS(S) G GGG(G)g	SSSS Gg
Test (Off-normal)	SSS(S) G <sub>O</sub>	SSS(S) G <sub>O</sub> G <sub>O</sub> G <sub>O</sub> G <sub>O</sub> (G <sub>O</sub> ) G <sub>O</sub> 2	SSSS G <sub>O</sub> G <sub>O</sub> 2
Walk Test Start	SSS(S) W <sub>S</sub>	SSS(S) W <sub>S</sub> W <sub>S</sub> W <sub>S</sub> W <sub>S</sub> (W <sub>S</sub> ) W <sub>S</sub> 2	SSSS W <sub>S</sub> W <sub>S</sub> 2
Walk Test End	SSS(S) W <sub>E</sub>	SSS(S) W <sub>E</sub> W <sub>E</sub> W <sub>E</sub> W <sub>E</sub> (W <sub>E</sub> ) W <sub>E</sub> 2	SSSS W <sub>E</sub> W <sub>E</sub> 2
Alarm Restore	SSS(S) R	SSS(S) R RRR(R) Z	SSSS RZ
Supervisory Restore	SSS(S) R <sub>S</sub>	SSS(S) R <sub>S</sub> R <sub>S</sub> R <sub>S</sub> R <sub>S</sub> (R <sub>S</sub> ) R <sub>S</sub> 2	SSSS R <sub>S</sub> R <sub>S</sub> 2
AC Restore	SSS(S) R <sub>A</sub>	SSS(S) R <sub>A</sub> R <sub>A</sub> R <sub>A</sub> R <sub>A</sub> (R <sub>A</sub> )A <sub>c</sub>	SSSS R <sub>A</sub> A <sub>c</sub>
LoBat Res.	SSS(S) R <sub>L</sub>	SSS(S) R <sub>L</sub> R <sub>L</sub> R <sub>L</sub> R <sub>L</sub> (R <sub>L</sub> )L <sub>B</sub>	SSSS R <sub>L</sub> L <sub>B</sub>
Trouble Res.	SSS(S) R <sub>T</sub>	SSS(S) R <sub>T</sub> R <sub>T</sub> R <sub>T</sub> R <sub>T</sub> (R <sub>T</sub> )t	SSSS R <sub>T</sub> t
Bypass Res.	SSS(S) R <sub>B</sub>	SSS(S) R <sub>B</sub> R <sub>B</sub> R <sub>B</sub> R <sub>B</sub> (R <sub>B</sub> )b	SSSS R <sub>B</sub> b

**Where:**

SSS or	SSSS = Subscriber ID	Gg = Test Code (1st & 2nd digits)
	A = Alarm Code-1st digit	G <sub>O</sub> G <sub>O2</sub> = Off Normal Test Code (1st & 2nd digits)
	Z = Typically Zone Number*-2nd digit	W <sub>S</sub> W <sub>Σ</sub> = Walk Test Start (1st & 2nd digits)
	Tt = Trouble Code (1st & 2nd digits)	W <sub>E</sub> W <sub>E2</sub> = Walk Test End (1st & 2nd digits)
	SpSp <sub>2</sub> = Supervisory Code (1st & 2nd digits)	R = Restore Code (Alarm)
	Bb = Bypass Code (1st & 2nd digits)	R <sub>S</sub> R <sub>S2</sub> = Restore Code (Supv) 1st & 2nd digits
	EAC = AC Loss Code (1st & 2nd digits)	R <sub>T</sub> t = Restore Code (Trbl)1st & 2nd digits
	LLB = Low Battery Code(1st & 2nd digits)	
	R <sub>B</sub> b = Restore Code (Byps)1st & 2nd digits	
R <sub>A</sub> AC =	Restore Code (AC)1st & 2nd digits	
R <sub>L</sub> LB =	Restore Code (Bat)1st & 2nd digits	

\*Zone numbers for: [\*] & [#], or [B] = 07 [1] + [\*], or [A] = 95  
[3] + [#], or [C] = 96

**Ademco Contact ID Reporting takes the following format:**

CCCC Q EEE GG ZZZ

where: CCCC = Customer (subscriber) ID

Q = Event qualifier, where:

E = new event , and R = restore

EEE = Event code (3 hexadecimal digits)

**Note:** For a complete list of event codes, refer to the central office receiver manual.

GG = Always 00

ZZZ = Zone/contact ID number reporting the alarm. System status messages (AC Loss, Walk Test, etc.) contain zeroes in the ZZZ location.

**TABLE OF CONTACT ID EVENT CODES**

Code	Definition
110	Fire Alarm Without Verification
111	Smoke Alarm With Verification
113	Waterflow Alarm
122	Silent Panic
123	Audible Panic
150	24 Hour Auxiliary
200	Fire Supervisory
301	AC Power
302	Low System Battery/Battery Test Fail
310	Ground Fault
321	Bell Trouble
351	Main Dialer Trouble

Code	Definition
352	Backup Dialer Trouble
353	LORRA Trouble
373	Fire Zone Trouble
380	Trouble (global)
521	Bell Bypass
524	Auxiliary Relay Bypass
551	Main/Backup Dialer Bypass
570	Zone Bypass
602	Normal Dialer Test
607	Fire Walk Test
608	Off-Normal Dialer Test

## Programming Communication Options

To program communications options, do the following:

1. With at least one alpha keypad (6139 or 6139R) connected to the system, power up the system. If necessary, refer to the *Final Power-Up* section for the power-up procedure.
2. Enter the programming mode by keying the following on the alpha keypad: **Master code (5 1 1 0) + 8 0**

**Press \*33 BACKUP DIALER PULSE/TONE**

Enter 0 for pulse dial, 1 for tone dial. Default =0

**Press \*40 PABX ACCESS CODE**

Enter up to 4 digits if PABX is needed to access an outside line. If fewer than 4 digits are needed to be entered, exit by pressing \* and next field number (e.g., 41). To clear entries from field, press \*40\*.

**Fields \*40, \*41, \*42:**  
Enter up to the number of digits shown. Do not fill unused spaces.  
Enter 0-9,  
# + 11 for '\*\*'  
# + 12 for '#'  
# + 13 for a pause  
(2.5 secs)

**Press \*41 PRIMARY PHONE No**

Enter up to 12 digits.

If fewer than 12 digits entered, exit by pressing \* and next field number (e.g., 42). To clear entries from field, press \*41\*

**Press \*42 SECONDARY PHONE No**

Enter up to 12 digits.

If fewer than 12 digits entered, exit by pressing \* and next field number (e.g., 43). To clear entries from field, press \*42\*

**Press \*43 SUBSCRIBER ACCOUNT No**

(Enter 3 or 4 digits).

Enter digits 0-9; #+11 = B; # +12 = C; # +13 = D; #+14 = E; or # +15 = F.

To clear entries from field, press \*43\*

See blank programming form for examples of account no. entries.

If only 3-digits are needed exit by pressing \* after the 3rd digit plus the next field number (e.g., 45).

**Press \*45 MAIN DIALER PULSE/TONE**

Enter [1] for Touch Tone or [0] for Pulse Dial (default = 0)

**Press \*46 REPORT FORMAT**

(\* applies to BOTH primary and secondary numbers)

Determines which format is to be used to report to the central station.

0 = 3+1; 4+1 ADEMCO Low Speed Standard (**this is the default**)

1 = 3+1; 4+1 Radionics Standard

2 = 4+2 ADEMCO Low Speed Standard

3 = 4+2 Radionics Standard

6 = 4+2 ADEMCO Express

7 = ADEMCO Contact ID Reporting (\* **Recommended**)

8 = 3+1; 4+1 ADEMCO Low Speed Expanded

9 = 3+1; 4+1 Radionics Expanded

**Press \*47 SPLIT/DUAL REPORTING**

Enter 0 to disable (Backup report only). **This is the default.**

	TO PRIMARY	TO SECONDARY
1 =	Alarms, Restore	Others
2 =	All except Test	Test
3 =	Alarms, Restore	All
4 =	All except Test	All
5 =	All	All

**Press \*49 PERIODIC TEST REPORT**

Select the desired test report interval.  
 0 = none; 1 = 24 hours (default) ; 2 = weekly; 3 = 30 days.  
 Test Report Code entered in field \*64 or \*84 is sent.  
 Must be set to "1" for fire installations.

**Press \*50 SESCOA/RADIONICS SELECT**

0 = Radionics (0-9, B-F reporting)  
 1 = SESCOA (0-9 only reporting)  
 Select 0 for all other formats. Default is 0.

**Press \*56 ZONE ASSIGNMENTS/ALARM REPORT CODES**

Program response types and report codes for dialer supervisory zones 11 and 12 as required.

**TO PROGRAM  
 SYSTEM STATUS  
 AND RESTORE  
 REPORT CODES  
 (\*58 - \*74)**

The following is a set of guidelines to be used for programming report codes. The actual digits that you enter depend upon the particular installation, and should be in agreement with you and the central station office receiving the signals. Use these guidelines to program this entire section.

**With a 3+1 or 4+1 Standard Format:** Enter a code in the *first* box: 1-9, A, B, C, D, E, or F. Enter "#+10" for A (this reports a "0" on some receivers), "#+11" for B, "#+12" for C, "#+13" for D, "#+14" for E, "#+15" for F.

An entry of "0" in the *first* box will disable a report.

An entry of "0" in the *second* box will result in automatic advance to the next field when programming.

**With an Expanded or 4+2 Format:** Enter codes in *both* boxes (1st and 2nd digits) for 1-9, or A-F, as described above.

An entry of "0" in the *first* box will disable a report.

An entry of "0" in the *second* box will eliminate the expanded message for that report.

**With Ademco Contact ID Reporting:** Enter a digit in the *first* box to enable the zone to report. Use a different digit for each zone until you have used up available digits. If the number of zones exceeds the number of available digits, begin with digit 1 again. This is an "enabling" code only and is not the actual code sent to the central station office. Entries in the *second* boxes will be ignored. For system status (non-alarm) codes, enter a "1" in the *first* box for all the system conditions you want to send to the central station.

An entry of "0" in the *first* box will disable the report.



In fire installations, you must program the control to transmit fire alarm, fire supervisory (if used), trouble, AC loss, and both normal and off-normal dialer test reports. In addition, test reports must be sent every 24 hours (program field \*49 = 1 (default)).

**Press \*58 SUPERVISORY REPORT CODE**

This will be sent if a zone goes into a supervisory condition.

**Press \*59 SUPERVISORY RESTORE CODE**

This will be sent when the supervisory condition is restored.

**Press \*60 TROUBLE REPORT CODE**    
This will be sent if a zone goes into trouble.

**Press \*61 BYPASS REPORT CODE**    
This will be sent when a zone is manually bypassed.

**Press \*62 AC LOSS REPORT CODE**    
Timing of this report is random within 6-12 hours after AC is lost. If AC restores before the report goes out, there is no AC loss report.

**Press \*63 LOW BAT REPORT CODE**    
This will be sent when a low battery condition exists in the system's standby battery.

**Press \*64 NORMAL TEST REPORT CODE**    
This is sent periodically (\* provided no trouble or supervisory conditions exist; otherwise an *Off-Normal Test* code - as programmed in \*84 - will be reported) to test that the control and phone lines are operational (frequency of report is selected in field \*49).

**Press \*69 GROUP RESTORES FOR TROUBLE and BYPASS**   
Enter 0 if a report is desired for each zone restoral, as it occurs. **This is the default.** Enter 1 if a report is not desired until all zones have restored.  
**Note:** "1" not applicable to Contact ID reporting.

**Press \*70 ALARM RESTORE REPORT CODE, 1st DIGIT**   
This is sent when the zone that caused an alarm is restored to its non-faulted condition. 2nd digit is automatically sent as the 2nd digit of the zone alarm report code programmed in field \*56, if expanded or 4+2 reporting is selected.

**Press \*71 TROUBLE RESTORE REPORT CODE**    
This is sent when a trouble in a zone is restored. Field \*69 applies.

**Press \*72 BYPASS RESTORE REPORT CODE**    
This is sent when a zone that has been bypassed is un-bypassed. Field \*69 applies.

**Press \*73 AC RESTORE REPORT CODE**    
This is sent when AC power has been restored after an AC power outage.

**Press \*74 LOW BAT RESTORE REPORT CODE**    
This is sent when a system low battery condition is restored to normal.

**Press \*79 MAIN/BACKUP DIALER ENABLE**    
Enter [1] to enable or [0] to disable each dialer **M B**  
(default = [1][1])

**Press \*84 MISCELLANEOUS REPORT CODES**     
FIRE W/T FIRE W/T OFF-  
START END NORM  
TEST

**Press \*94 DOWNLOAD PHONE NUMBER**   
Enter up to 12 digits;  
0-9, # +11 for "[\*]", # + 12 for "#", # + 13 for a pause. Do not fill unused spaces. End field by entering "\*". To clear entries, press \*94\*.

**Press \*95 RING DETECTION COUNT FOR DOWNLOADING**



Refer to the chart below and program this field accordingly.

<b>Answering Machine</b>	<b>Downloading</b>	<b>Field *95 Programming</b>
No	No	Set for value of "0"
<b>Yes</b>	No	Set for value of "0"
No	<b>Yes</b>	Set for value other than "0" (1-14).
<b>Yes</b>	<b>Yes</b>	"15" to bypass answering machine.

**\*96 INITIALIZE DOWNLOAD ID AND SUBSCRIBER ACCT. No. FOR DOWNLOADING** (No data entry required)

This completes the communication programming.

Exit the programming mode by keying \*99.

# Section 12.

## ZONE RESPONSE TYPE DEFINITIONS

This section provides the following information:

- General information about zone response types
- Zone response types

### General Information

You must assign a zone type to each zone, which will define the way in which the system will respond to faults in that zone. Zone types are defined below.

### Zone Response Types

#### **Type 00** **Zone Not Used**

- Program this zone type for zones that are not used.

#### **Type 06** **24-hour Silent Alarm**

- Sends a report to the central station, but provides no keypad display or sounding.
- Usually assigned to a zone containing an emergency button.

#### **Type 07** **24-hour Audible Alarm**

- Provides an alarm sound at the keypad and an audible external alarm.
- Sends a report to the central station.
- Usually assigned to a zone that has an emergency button.

#### **Type 08** **24-hour** **Auxiliary Alarm**

- Provides an audible alarm at the keypad only. **No bell output is provided.**
- Sends a report to central station.
- Usually assigned to a zone containing a button for use in personal emergencies, or to a zone containing non-fire related monitoring devices such as temperature sensors, etc.

#### **Type 09** **Fire Alarm** **Without Verification**

- Provides a fire alarm when zone is shorted.
- Provides a trouble response when zone is open.
- Assigned to a zone using fire alarm initiating devices or a zone that is wired to a FACP fire alarm contact.
- Can be bypassed only by the installer (Master Code).
- Bell output for fire can be programmed as either pulsing or steady (field \*77).

#### **Type 16** **Fire Alarm** **With Verification**

- Provides a fire alarm when zone is shorted, but only after alarm condition has been verified. This is done as follows:  
After initial short circuit is detected, zone is reset for 6 seconds. A subsequent short circuit within 90 seconds triggers a fire alarm.
- Provides a trouble response when zone is open.
- Can be bypassed only by the installer (Master Code).
- Bell output for fire can be programmed as either pulsing or steady (field \*77).

**Type 17  
Fire Waterflow Alarm**

- Provides a fire alarm when zone is shorted for longer than the time programmed in field \*78 delay time setting. The combined sensor and program field \*78 delay must not exceed 90 seconds.
- Provides either a trouble on an open circuit (field \*32=0) or a supervisory on open circuit (field \*32=1).
- Usually assigned to a zone containing a fire sprinkler waterflow sensor.
- Bell output may be programmed to remain latched on alarm or to restore when zone restores (see field \*76).

**Type 18  
Fire Sprinkler  
Supervisory**

- Provides a supervisory indication when a zone is shorted for longer than the time programmed in field \*78 delay time setting when delay is enabled in field \*57 . The combined sensor and program field \*78 delay must not exceed 90 seconds.
- Provides either a trouble on an open circuit (field \*32=0) or a supervisory on an open circuit (field \*32=1).
- No bell output is is provided.
- Usually assigned to a zone containing fire sprinkler supervisory sensors such as Post-Indicator-Value sensors.
- Assigned to a zone that is wired to a FACP supervisory contact

**Type 19  
24-Hr. Trouble**

- Provides a trouble response on an open or short circuit, and on system zone faults.
- Usually assigned to system zones such as Zone 10 (earth ground fault) and Zone 11 (main dialer fault).
- Assigned to a zone that is wired to a FACP trouble contact

# Section 13. DATA FIELD DESCRIPTIONS

## Description of System Data Fields

THE BLANK PROGRAMMING FORM INCLUDED WITH THIS MANUAL SHOULD BE USED TO RECORD THE DATA FOR THIS INSTALLATION

### Defaults (where applicable) Are Indicated In Text

The following is a table containing a list of all data fields in this control (presented in numerical order). If you have performed the programming instructions that were included with the installation of each of the various peripheral devices covered in previous sections, this table will simply serve as a reference for all data fields in the system. If you have decided to program all the data fields in the system at one time (and therefore did not perform the programming indicated previously in each section), you can use this table to program all the data fields now.

**\*20 MASTER CODE**

The Master code is used by the installer to reenter the program mode and to assign the user code for the main user (user #2) **in the normal operation mode**, via the keypad. The *MASTER* code should not be given to the user. See "Master Code" in the *SYSTEM OPERATION* section for procedure.

Enter 4 digits, 0–9. Default is **5-1-1-0**.

**\*27 OUTPUT TO LONG RANGE RADIO**

*\*This option is for future use and has not been evaluated by UL. It must be disabled (set to "0"; this is the default setting)*

If output to LRR is selected here, all messages that are programmed to go to the primary telephone line receiver will also be sent to the 7720 PLUS radio. These messages will always be in Contact ID format (not affected by entry in field \*46). The data line is supervised as well as certain functions in the radio. If communication is lost or a trouble develops, a message will be attempted to be sent via both radio and telephone to the central station.

Enter the first digit of the Trouble dialer report for loss of contact with the radio; enter 1–9, B (# +11), C (# +12), D (# +13), E (# +14), or F (# +15). The 2nd digit of Trouble Dialer Report is automatically the 2nd digit from field \*60.

**Note:** Normal trouble restore report (\*71) is sent on restore of the condition.

**Note:** The Radio should be programmed for device address 3 on the keypad lines.

**\*30 ALARM BELL TIMEOUT**

This field determines whether the bell output will shut off after time allotted, or continue until manually turned off. Enter as follows: 0 = No timeout; 1 = 4 min.; 2 = 8 min.; 3 = 12 min.; 4 = 16 min. (default is "No Timeout") When used, the bell must be programmed to sound for at least 5 minutes.

**DIALER  
PROGRAMMING  
(\*40-\*50)**

**Fields \* 40, \* 41, \*42:**  
Enter up to the number of digits shown. Do not fill unused spaces.  
Enter 0-9,  
# + 11 for "\*"   
# + 12 for "#"  
# + 13 for a pause (2.5 secs)

**\*31 AUXILIARY RELAY TIMEOUT**   
This field determines whether the auxiliary relay will shut off after time allotted, or continue until manually turned off. Enter as follows: 0 = No timeout; 1 = 4 min.; 2 = 8 min.; 3 = 12 min.; 4 = 16 min. (default)

**\*32 SUPERVISORY ON OPEN/SHORT**   
If enabled (enter a [1]) this field provides a supervisory condition on BOTH an open or short circuit. If disabled, [0], an open will cause a Trouble condition, and a short will cause a Supervisory condition. (default = 0)

**\*33 BACKUP DIALER PULSE/TONE**   
Enter [1] for Touch Tone or [0] for Pulse Dial (default = 0)

**\*34 AUXILIARY RELAY FUNCTION**   
This field determines how the on-board auxiliary relay will be used. [0] = activate on Trouble/Supervisory, [1] = activate on Alarm, silenced by pressing the silence/reset button, or code + off (if remote keypad is used), [2] = Smoke Detector Reset, [3] = Battery Saver Option, [4] = activate on Alarm, silenced by code + #67 (only if a remote keypad is used)  
**Note:** When function 1 or 4 is selected, program fields \*85 and \*86 to select zones which will trigger aux. relay. When function 1 is selected, program aux. relay timeout in field \*31.

**\*40 PABX ACCESS CODE** (See Box at Left)   
Enter up to 4 digits if PABX is needed to access an outside line. If fewer than 4 digits are needed to be entered, exit by pressing \* and next field number (e.g., 41). To clear entries from field, press \*40\*.

**\*41 PRIMARY PHONE No.**   
Enter up to 12 digits. If fewer than 12 digits entered, exit by pressing \* and next field number (e.g., 42). To clear entries from field, press \*41\*

**\*42 SECONDARY PHONE No.**   
Enter up to 12 digits. If fewer than 12 digits entered, exit by pressing \* and next field number (e.g., 43). To clear entries from field, press \*42\*

**\* 43 SUBSCRIBER ACCOUNT. No**   
(Enter 3 or 4 digits).  
Enter digits 0-9; #+11 = B; # +12 = C; # +13 = D; #+14 = E; or # +15 = F.  
To clear entries from field, press \*43\*  
See blank Programming Form for examples of Account No. entries.  
If only 3-digits are needed exit by pressing \* after the 3rd digit plus the next field number (e.g., 45).

**\* 45 MAIN DIALER PULSE/TONE**   
Enter [1] for Touch Tone or [0] for Pulse Dial (default = 0)

\*46

**REPORT FORMAT**

(\* applies to BOTH primary and secondary numbers)

Determines which format is to be used to report to the central station.

0 = 3+1; 4+1 ADEMCO Low Speed Standard (**this is the default**)

1 = 3+1; 4+1 Radionics Standard

2 = 4+2 ADEMCO Low Speed Standard

3 = 4+2 Radionics Standard

6 = 4+2 ADEMCO Express

7 = ADEMCO Contact ID Reporting (\* **Recommended**)

8 = 3+1; 4+1 ADEMCO Low Speed Expanded

9 = 3+1; 4+1 Radionics Expanded

\*47

**SPLIT/DUAL REPORTING**

Enter 0 to disable (Backup report only). **This is the default.**

	TO PRIMARY	TO SECONDARY
1 =	Alarms, Restore,	Others
2 =	All except Test	Test
3 =	Alarms, Restore	All
4 =	All except Test	All
5 =	All	All

\* 49

**PERIODIC TEST REPORT**

Select the desired test report interval.

0 = none; 1 = 24 hours; 2 = weekly; 3 = 30 days. Default is **24 hrs.**

Test Report Code entered in field \* 64 (or *Off-Normal Test Report* \*84) is sent. Must be set to "1" for fire installations.

\* 50

**SESCO/RADIONICS SELECT**

0 = Radionics (0-9, B-F reporting)

1 = SESCOA (0-9 only reporting)

Select 0 for all other formats. Default is **0**.

\*56

**ZONE ASSIGNMENT/ALARM REPORT CODES**

*REFER TO THE ZONE ASSIGNMENT TABLE FOR \*56 IN THE CENTERFOLD PROGRAMMING FORM.*

This is an interactive menu mode that is used to program zone numbers, zone types, and alarm report codes. This mode can also be used for entering Alpha descriptors for zones (however, we recommend entering descriptors in menu mode \*82).

Upon entering menu mode \*56, the following is displayed:

**Zone Number (Zn):** Enter the zone number that you wish to program (or [0][0] to leave zone programming).

Enter Zn Num.	
(00 = Quit)	01

Zone 01 entered ↑

Zn	ZT	RC
01	09	10

Press [\*]. A summary display will come up, showing the status of that zone's program.

If it is programmed satisfactorily, press [#] to back up one step and enter another zone number, if desired.

If the zone is not programmed, or you want to change it, press [\*]. A prompt for Zone Type will appear.

↓ Zone Number

01 Zone Type	
Fire	09

Zone Type ↑

**Zone Type (ZT):** Each zone must be assigned to a zone type, which defines the way in which the system responds to faults in that zone. Enter the zone type code (or change it, if necessary). Zone types are listed below.

- |                           |                           |
|---------------------------|---------------------------|
| 00 = Not Used             | 16 = Fire w/ Verification |
| 06 = 24 Hr Silent         | 17 = Fire Waterflow       |
| 07 = 24 Hr Audible        | 18 = Fire Supervisory     |
| 08 = 24 Hr Aux            | 19 = 24 Hour Trouble      |
| 09 = Fire W/verification. |                           |

Default values for zones 01 to 05 are:

<b>Zone No.(Zn):</b>	<b>01</b>	<b>02</b>	<b>03</b>	<b>04</b>	<b>05</b>
Zone Type Default:	09	09	09	09	09

When the display shows the zone type you want, press [\*] to advance to...

01 Report Code		
1st 00	2nd 00	00

**Report Code (RC):** The report code consists of 2 hexadecimal digits, each in turn consisting of 2 numerical digits. For example, for a report code of "3C", enter [0][3] for "3" and [1][2] for "C". Enter the numbers and press [\*] to advance to...

Typical Summary Display

Zn	ZT	RC
01	09	3C

A summary of the programmed values for the selected zone will be displayed. If all is okay, press [\*].

Accepted report code ↑

Program Alpha?		
0 = No	1 = Yes	0

**Custom Alpha Editing:** For all zone types, the next request is to enter Alpha descriptors for the zones. The entry may be done now (enter 1), or may be done at a later time via \*82 mode (enter 0). See *Section 10. ALPHA DESCRIPTION PROGRAMMING* for procedure.

Enter Zn Num.	
(00 = Quit)	00

When all entries to be made for the zone at this time are complete, the next zone number can be entered for programming, or zone programming can be ended by entering [0][0] as the next "zone number".

**Notes:**

1. *In field \*56, at the summary line for each zone, the entered values can be checked. If it is desired to change anything, press [#] to move to the previous entry. Press [#] a number of times to move to earlier entries. Press [\*] to move to later entries again.*
2. *Zone entries can be reviewed by pressing [#][5][6]. Changes cannot be made here, so this is safer for review. Enter the first zone number to be viewed and press [#]. To view each zone, press [#] and the zone number will advance to the next programmed zone. When the end of the list is reached, press [0][0] to exit. This method of exiting may also be done at any time during the review.*

01 Zone Type Not Used	00
--------------------------	----

01 Delete Zone? 1 = Yes 0 = No
-----------------------------------

3. To either temporarily or permanently remove a zone from the system, go into programming mode and press [\*][5][6]. Enter the zone number and press [\*]. At the "Zone Type" prompt, enter [0][0] and [\*]. This sets the type of the zone to "Not Used". The next prompt will be "Delete Zone?". "Yes" will permanently remove the zone from the system, while "No" will disable it but retain all data except the original zone type. You can then go back to this zone later and put back an active Zone Type to re-enable it.

**\*57 Zone Type 18 Delay Enable**

0 = Disable delay (ignore delay programmed in field \*78)  
1 = Enable delay ( use delay programmed in field \*78) (default)

**TO PROGRAM  
SYSTEM STATUS  
AND RESTORE  
REPORT CODES  
(\* 58 - \* 74)**

The following is a set of guidelines to be used for programming report codes. The actual digits that you enter depend upon the particular installation, and should be in agreement with you and the central station office receiving the signals. Use these guidelines to program this entire section.

**With a 3+1 or 4+1 Standard Format:** Enter a code in the *first* box: 1-9, A, B, C, D, E, or F. Enter "#+10" for A (this reports a "0" on some receivers), "#+11" for B, "#+12" for C, "#+13" for D, "#+14" for E, "#+15" for F.  
An entry of "0" in the *first* box will disable a report.  
An entry of "0" in the *second* box will result in automatic advance to the next field when programming.

**With an Expanded or 4+2 Format:** Enter codes in *both* boxes (1st and 2nd digits) for 1-9, or A-F, as described above.  
An entry of "0" in the *first* box will disable a report.  
An entry of "0" in the *second* box will eliminate the expanded message for that report.

**With Ademco Contact ID Reporting:** Enter a digit in the *first* box to enable the zone to report. Use a different digit for each zone until you have used up available digits. If the number of zones exceeds the number of available digits, begin with digit 1 again. This is an "enabling" code only and is not the actual code sent to the central station office. Entries in the *second* boxes will be ignored. For system status (non-alarm) codes, enter a "1" in the first box for all the system conditions you want to send to the central station. An entry of "0" in the *first* box will disable the report.

- SYSTEM STATUS REPORT CODES (\*58-\*64)**
- \*58 SUPERVISORY REPORT CODE**  |   
This will be sent when a system supervisory condition exists.
  - \*59 SUPERVISORY RESTORE REPORT CODE**  |   
This will be sent upon restoral of a system supervisory condition.
  - \*60 TROUBLE REPORT CODE**  |   
This will be sent if a zone goes into trouble.
  - \*61 BYPASS REPORT CODE**  |   
This will be sent when a zone is manually bypassed.
  - \*62 AC LOSS REPORT CODE**  |   
This report is sent at a random time between 6 and 12 hours after AC power is lost. If AC restores before the report goes out, there is no AC loss report.
  - \*63 LOW BAT REPORT CODE**  |   
This will be sent when a low battery condition exists in the system's standby battery.

**RESTORE  
REPORT CODES  
(\*69-\*74)**

**\*64 NORMAL TEST REPORT CODE**    
This is sent periodically to test that the communicator and phone lines are operational (frequency of report is selected in field \*49).

**\*69 GROUP RESTORES FOR TROUBLE, BYPASS**   
Enter 0 for no (report for each restore), or 1 for yes (report after all zones restored). Default is "0". **Note:** "1" not applicable to Contact ID reporting.

**\*70 ALARM RESTORE REPORT CODE, 1st DIGIT**   
This is sent when a zone alarm has been restored. The 2nd digit is automatically sent as the 2nd digit of the zone alarm report code programmed in field \*56, if expanded or 4+2 reporting is selected.

**\*71 TROUBLE RESTORE REPORT CODE**    
This is sent when a trouble in a zone is restored. Field \*69 applies.

**\*72 BYPASS RESTORE REPORT CODE**    
This is sent when a zone that has been bypassed is un-bypassed. Field \*69 applies.

**\*73 AC RESTORE REPORT CODE**    
This is sent when AC has been restored.

**\*74 LOW BAT RESTORE REPORT CODE**    
This is sent when a system low battery condition has been restored.

**MISCELLANEOUS  
OPTIONS  
(\*76 - \*86)**

**\*76 WATERFLOW ALARM SILENCING**   
Enter 0 for Manual Silence only (default); enter 1 for automatic silence when waterflow ceases, provided no other fire alarms are present.  
The automatic silence option can only be used with the permission of the local AHJ.

**\*77 ALARM BELL SOUND**   
Enter 0 for pulsing (default); enter 1 for steady  
**NOTE:** *The "pulsing" option causes the bell to sound using the NFPA Three Tone Temporal Pattern*

**\*78 ZONE TYPES 17 and 18 DELAY**    
Enter 00-99 seconds (default = 00)  
Note: You must enable the Delay for Zone Type 18 in field \*57.  
The combined sensor and program field \*78 must not exceed 90 seconds.

**\*79 MAIN/BACKUP DIALER ENABLE**    
Enter 0 to disable; enter 1 to enable (default= 1,1) **M B**

**\*82 CUSTOM ALPHA EDITING**  
May also be entered from the interactive program field \*56. See the Section on *ALPHA DESCRIPTION PROGRAMMING* for procedures.

**\*84 MISCELLANEOUS REPORT CODES**  
       
**FIRE WALK TEST START** **FIRE WALK TEST END** **OFF-NORMAL DIALER TEST**  
Enter 2 hex digits for each. (Default for each = 0)

**\*85 ZONES 1-7 BELL & AUX. RELAY ACTIVATION**

**1 2 3 4 5 6 7**

0 = none (default for 6 and 7); 1 = bell only (default for 1-5) 2 = aux. relay only; 3 = bell & aux. relay

**\*86 ZONES 10-12, 95 and 96 BELL & AUX. RELAY ACTIVATION**

**0 10 11 12 95 96**

0 = none (default) ; 1 = bell only; 2 = aux. relay only; 3 = bell & aux. relay

**DOWNLOAD  
INFORMATION  
(\*94, \*95)**

**\*94 DOWNLOAD PHONE NUMBER**

Enter up to 12 digits;

0-9, # +11 for "\*", # + 12 for "#", # + 13 for a pause. Do not fill unused spaces. End field by entering \*. To clear entries from field, press \*94\*.

**\*95 RING DETECTION COUNT FOR DOWNLOADING**

Enter number of rings before control picks up phone line (or 0 or 15). Refer to the chart below and program this field accordingly.

	Answering Machine	Downloading	Field *95 Programming
	No	No	Set for value of "0"
	Yes	No	Set for value of "0"
	No	Yes	Set for value other than "0" (1-14).
	Yes	Yes	"15" to bypass answering machine.

**\*96 INITIALIZE DOWNLOAD ID AND SUBSCRIBER ACCT. No. FOR DOWNLOADING**

(No data entry required, press \*96)

**\*97 SET ALL PROGRAM FIELDS TO DEFAULT VALUES**

(No data entry required, pressing \*97 automatically loads all defaults).

**\*98 EXITS PROGRAMMING MODE and prevents re-entry by :  
Master Code + 8 + 0**

**\*99 EXITS PROGRAMMING MODE and allows re-entry by:  
Master Code + 8 + 0 or by: Power-up then "\*" and "#".**

**TO EXIT  
PROGRAMMING MODE  
(\*98 or \*99)**

# Section 14. REMOTE PROGRAMMING AND CONTROL (DOWNLOADING)

## General Information

The Ademco 5110XM can be remotely programmed from an IBM compatible Personal Computer (PC), a HAYES Modem, and Ademco's V-LINK® Software (as specified below).

Programming the control from a remote location is protected against compromise by someone attempting to defeat the system, using multi-levels of security protection:

1. **Security Code Handshake:** An 8-digit download ID code must be matched between the control and the downloader .
2. **Site Initiated Remote Programming:** The installer initiates the callback from the subscriber premises (by entering Master code + # + 1). All parameters can then be downloaded via the phone lines using a personal computer.
3. **Station Initiated Remote Programming:** The operator calls the site from your office to initiate the download call. The control hangs up and then calls back the PC via the preprogrammed telephone number. The unit can then be uploaded, downloaded, or controlled from your office.
4. **Data Encryption:** Data passed between the PC and the control is encrypted for security so that it is very difficult for a foreign device tapped into the phone line to take over communication and substitute system compromising information.

**UL**

Remote programming may only be used when a service technician is at the site during downloading.

## Equipment Required

### At the premises:

- Ademco 5110XM and keypad.

### At the installer's office/home:

- An IBM PC compatible computer.
- *Either* a HAYES brand SMARTMODEM 1200 [Level 1.2 or higher external or Level 1.1 or higher (with 4 position DIP switch) internal style], *or* a HAYES brand Optima 24 Plus FAX96 Modem (set Aux Modem command to: X&D2&C1&Q0).
- V-LINK® Downloading Software Diskette (at revision level 3.1 or higher).
- Appropriate interconnecting cables.

## Initial Download

### Site Initiated:

1. Enter program mode by entering Master code (5110) + 80.
2. Program the download phone number in field \*94.
3. Initialize the download ID and subscriber account number by entering \*96.
4. Exit program mode by entering \*98 (prevents re-entry using Master code) or \*99 (allows re-entry using Master code).
5. Wait approx. 1 minute for system to stabilize. Then initiate the downloading session by entering Master code + # + 1 (this causes the control to make the phone call).

### Central Station Initiated:

1. Enter program mode by entering Master code (5110) + 8 0.
2. Program the download phone number in field \*94.
3. Program the ring detect count to "4" in field \*95. The central station can change this as required when on-line with the control.
4. Initialize the download ID and subscriber account number by entering \*96.
5. Exit program mode by entering \*98 (prevents re-entry using Master code) or \*99 (allows re-entry using Master code).
6. Wait approx. 1 minute for system to stabilize. Then the central station can initiate the downloading session by calling the control.

### Remote Programming Information

The downloading system can perform many functions while in contact with the control. Besides uploading and downloading, the status of the system can be observed and various commands can be initiated, as follows:

- Silence alarms, troubles, etc.
- Bypass a zone.
- Force the system to accept a new program download.
- Shut down communication (dialer) functions (non-payment of monitoring fees in an owned system).
- Inhibit local keypad programming (prevents account takeover).
- Command the dialer to upload a copy of its resident program to the office.
- Read: AC power status, lists of faulted zones, bypassed zones, zones currently in alarm, and zones currently in trouble.

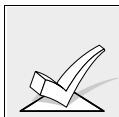

After the control and the PC have established valid communication, each keypad on the system will become inactive and will display "**CC**" or "**MODEM COMM.**" The keypads will become active after the download communication is terminated. The detailed operation of the download functions is covered in the installation instructions for the V-LINK® downloading software diskette.

### Remote Programming Advisory Notes

- The Control does not scan zones for fault conditions and ignores keypad functions during the time interval stated above.
- A copy of the program downloaded may be produced from the IBM PC compatible computer, using the product's internal report generator, when an optional printer is connected (consult your PC manual for proper printer and connections).
- Program upload time - one minute, thirty seconds for a complete program.
- Program download time - depends on changes. Two minutes forty seconds for complete program.

# Section 15. SYSTEM OPERATION

This section provides the following information:

- User codes
- Keypad functions
- Emergency keys

## User Codes

\* User codes are required only if a keypad is installed on the control.

This system provides 1 Master code and 5 secondary codes (Users 2-6). These are described below.

### Master Code

The installer programs the 4-digit Master Code initially as part of the programming procedure. The factory default Master code is "5-1-1-0", but may be changed in field \*20.

The Master code is the only code that can allow re-entry into programming mode and also, in normal operation mode, is used to enter the 4-digit code for the main user (user #2), which allows access to the normal functions of the system (The main user {#2} may also enter additional users, 3-6).

See *MECHANICS OF PROGRAMMING* for information on exiting the programming mode via fields \*98 or \*99.

### User Codes

**In normal operation mode**, the Master (installer's) code (and user code #2) may be used to assign up to 5 additional 4-digit user codes. It can also be used to remove secondary codes from the system (individually).

**To assign (or change) a Secondary user code**, enter (via keypad):

Master Code + [CODE key] + User # (2-6) + desired  
Secondary Code (4-digits)

The system will emit a single beep when each secondary code has been successfully entered.

**To delete a Secondary user code**, enter (via keypad):

Master Code + [CODE key] + User # (2-6)

- Notes:**
- All Master and Secondary user codes permit access to the system for silencing and resetting alarms.
  - The Master code may assign user codes 2-6; User 2 may assign user codes 3-6
  - The Master code may bypass ALL zones while users 2-6 may bypass 24 hour non-fire zones only.
  - The Master code may initiate both the Walk Test and Fire Drill; User 2 may initiate the Fire Drill only; Users 3-6 may NOT initiate any of the test modes.
  - If a secondary code is inadvertently repeated for different users, the lower user number will take priority.

USER CODE FUNCTION SUMMARY TABLE

USER #	ENTER PROGRAM MODE	SILENCE ALM, SUP, & TRBL	ADD / CHANGE USERS	BYPASS ZONES	ENTER TEST MODES
1 (MASTER)	YES	YES	1 - 6	ALL	WALK TEST, FIRE DRILL
2 (MAIN USER)	NO	YES	2 - 6	24 HR.	FIRE DRILL
3 - 6	NO	YES	NO	24 HR.	NONE

## Keypad Functions

The keypad, if used, allows the user to silence alarm and trouble sounders and perform other system functions, such as bypassing zones, and display zone descriptors. Zone and system conditions (alarm, trouble, bypass) are displayed in the Display Window. The system is in the "System Normal" condition when all zones are intact. If NOT, faulted zones will be displayed in numerical order.

### System Commands

The following is a brief list of system commands. For detailed information concerning system functions, refer to the User's Manual.

#### SUMMARY OF SYSTEM COMMANDS

<b>Silencing Sounders</b>	Code +OFF [1] or press Silence/Reset button
<b>Resetting Smoke Detectors and Clearing Alarm Memory</b>	Code +OFF [1] or press Silence/Reset button Twice
<b>Bypassing Zones</b>	Code +BYPASS [6] + Zone number(s)
<b>Un-bypassing Zone Types 9, 16, 17, 18, 19 and System Zones 6 and 10-13</b>	Code + Bypass + [6] + Zone Number(s)
<b>Un-bypassing Other Zones</b>	Code +OFF [1]
<b>Fire Walk Test Mode</b>	Master Code + # + 68 (Code + OFF to exit)
<b>Fire Drill Mode</b>	Master or User #2 Code + # + 69 (Code + OFF to exit)

### Emergency Keys

There are three emergency key pairs or (on some keypads) lettered keys that, if programmed, can be used to manually initiate alarms and send a report to the central station.

Each can be individually programmed for 24-hour Silent, Audible, Auxiliary or Fire alarm responses. The emergency function is activated when both keys of the appropriate key pair are pressed at the same time, or the appropriate lettered key is pressed for at least 2 seconds.

The emergency functions are identified by the system as follows:

<b>Keys</b>	<b>Displayed as Zone</b>
[1] & [*], or [A]	95
[*] & [#], or [B]	7
[3] & [#], or [C]	96

#### **Notes:**

- Key [D], if present, is not active here.

These keys are intended to be used only when the 5110XM is installed as a stand-alone control.

## Section 16. TESTING THE SYSTEM

### Test Procedure

After installation is completed, the 5110XM System should be carefully tested, as follows:

1. With the System in the "**SYSTEM NORMAL**" state all zones should be intact. If a fault message is displayed, press the [\*] key to display the faulted zone(s). Restore faulted zone(s) if necessary, so that "**SYSTEM NORMAL**" message is displayed.
2. Perform the FIRE WALK TEST This test causes the keypad buzzer to beep and the optional alarm sounders (if connected) to sound momentarily in response to short circuits on zones programmed as types 09, 16, or 17 only. The control will NOT be active during this test

To initiate the ONE MAN FIRE WALK TEST enter the Master Code + [#] [6][8] on any remote keypad. When first activated alarm sounders (if used) will sound for 3 seconds and all keypad segments will light to verify proper operation. The control will send a walk test start report to the central station. The following will be displayed on an alpha keypad:

**Fire Walk Test  
In Progress**

*\* or [TEST CF] on fixed-word keypads*

Fault and restore each fire alarm sensor one at a time. Each fault will cause keypads to beep and fire bells (if used) to sound. (Auxiliary relay will also ding if set for alarm function 1 in field \*34 and if assigned in field \*85 to the fire zone that was faulted.) The keypads will also display the faulted zone for as long as the fault remains. The 5110XM will initiate an automatic smoke detector reset 10 seconds after a smoke detector has been faulted in order to reset that smoke. Once reset, the keypad display for that zone should clear.

To exit this test enter ANY User Code + OFF, or the test will automatically terminate after 30 minutes if no faults are sensed. The control will send a walk test end report to the central station.

**Alarm messages will be sent to the central station during the following tests 3 and 4. Notify them *in advance* that tests will be in progress.**

3. With the System in the "**SYSTEM NORMAL**" state fault one or more zones. Silence alarm sounder(s) by pressing the silence/reset button or entering the **code** and pressing **OFF** (if a keypad is being used).
4. Check the keypad-initiated alarms (if used) by pressing the appropriate emergency key(s). If the system has been programmed for audible emergency, the keypad and built-in warning buzzer will emit a steady alarm sound, and **ALARM and zone number** will be displayed. Silence alarm sounder(s) by pressing the silence/reset button (or entering the **code** and pressing **OFF**). If the control has been programmed for silent alarm, there will be no audible alarms or displays, but a report will be sent to the central station.
5. Notify the central station when all tests are finished, and verify results with them.

## Dialer Test

The 5110XM may be programmed to send periodic test reports ranging from every 24 hours, weekly, or monthly, as determined in field \*49. The first test report will be sent 12 hours after initial powerup, after exiting the program mode, or after a download session, whichever is applicable. As long as there are no existing alarm, supervisory, or trouble conditions present the normal test report will be sent (as programmed in field \*64). If alarm, supervisory or trouble conditions are present at the time of the test report an *OFF-NORMAL* report will be sent instead (\*84).

## Trouble Conditions (See Troubleshooting Guide also)

### General Information

A rapid beeping at the built-in warning buzzer (or if used, at the keypad buzzer accompanied by the word "CHECK" on the keypad's display) indicates that there is a trouble condition in the system. The audible warning sound can be silenced by pressing the Silence/Reset button (or by entering code + off.) Instruct users to call for service immediately upon seeing any of the following messages.

### "Check" and "Battery" Displays

When the problem has been corrected, the display can be cleared by pressing the Silence/Reset key or by entering code plus off a second time..

- **A display of "CHECK"** accompanied by a zone number means there is an open circuit condition on a fire zone, or that there is a system trouble.
- **A display of "BAT"** (Fixed-word keypads) **or "SYSTEM LO BAT"** (Alpha keypads) **with no zone number** indicates that the system's main standby battery is weak. The built-in battery trouble LED also lights.

### Telephone Line Failure

A display of "**check 11**" or "**check 12**" (Fixed-word keypads), or "**check 11 main dialer**" or "**check 12 back-up dialer**" (Alpha keypads), indicates that a monitored telephone line has been cut (or disconnected). The keypad will also produce a trouble sound, (silence by pressing the reset key or entering code plus OFF). The built-in Telco Fault LED also lights.

### Power Failure

Power failure may be exhibited in one of the following ways:

- **If there is no keypad display at all**, operating power for the system has stopped and the system is inoperative. The built-in AC Power LED also goes off.
- **If the message "AC LOSS"** (Alpha keypads) **or "NO AC"** (Fixed-word keypads) **is displayed**, the keypad is operating on battery power only.

### Other Displays (Fixed Word displays are in parenthesis)

**Busy-Standby (dl)**. If this remains displayed for more than 1 minute, the system is disabled.

**Modem Comm (CC)** The system is in communication with the central station for change of function or status verification.

**Comm. Failure (FC)** A communication failure has occurred.

**Open Circuit (OC)** The keypad is not receiving signals from the control and sees an open circuit.

**Long Rng Trbl (bF)** Back-up LRR communication failure.

### TO THE INSTALLER

Regular maintenance and inspection (at least annually) by the installer and frequent testing by the user are vital to continuous satisfactory operation of any alarm system.

The installer should assume the responsibility of developing and offering a regular maintenance program to the user as well as acquainting the user with the proper operation and limitations of the alarm system and its component parts. Recommendations must be included for a specific program of frequent testing (at least weekly) to insure the system's proper operation at all times.

# Section 17. TROUBLESHOOTING GUIDE

## SYSTEM

SYMPTOM	POSSIBLE CAUSE	REMEDY
<b>1. Low Battery message on keypad or battery trouble LED lit.</b>	1a. "Bat" or "System Low Bat"	1a. System battery is low or missing.
<b>2. Nuisance or phantom alarm.</b>	2a. Sensors not properly installed, wired, or monitored.	2a. Check installation to see if in accordance with established procedure.
<b>3. "AC POWER" light off.</b>	3a. Interrupted AC power supply.	3a. Check transformer connection and Power line circuit breaker.
<b>4. "CHECK" and zone number 1-5 is displayed.</b>	4a. Control has sensed an open circuit on one or more zones	4a. Check the sensor or the loop wiring in the affected zone. The system will not display "System Normal" until this condition is corrected (or the affected zone is bypassed).

## CONTROL

SYMPTOM	POSSIBLE CAUSE	REMEDY
<b>2. Digital control message not being received.</b>	2a. Ademco 5110XM in FIRE WALK TEST mode. 2b. Telephone connection not secure. 2c. Digital control malfunctioning. 2d. Telephone number in program needs prefix or access code. 2e. Telephone call to central monitoring station requires operator assistance.	2a. Remove from TEST mode. 2b. Check all connections. 2c. Check with a different Ademco 5110XM. 2d. Program prefix or access code into the Ademco 5110XM. 2e. Ademco 5110XM system cannot work in this situation.
<b>3. Ademco 5110XM doesn't respond to keystrokes on keypad.</b>	3a. "CC" or "MODEM COMM" displayed. 3b. "d1" or "System Busy" displayed. 3c. Keypad address setting incorrect.	3a. System is in communication with downloader at central station. Wait until download session is finished. 3b. System has just been powered and is in its one minute initialization. To bypass this time, press '#' + '0'. 3c. Keypads must be set for address 31 (non-addressable mode).

## SMOKE DETECTOR

SYMPTOM	POSSIBLE CAUSE	REMEDY
<b>1. Detector alarms, no apparent reason.</b>	1a. Dust, dirt in sensing chamber. 1b. Improper location. 1c. Unit malfunctioning.	1a. Clean unit's sensing chamber with vacuum cleaner per unit's instructions. 1b. See unit's instructions for locations to avoid. Relocate as necessary. 1c. Replace detector.

## CONTACTING TECHNICAL SUPPORT

**PLEASE,**

**Before you call Technical Support, be sure you:**

- **READ THE INSTRUCTIONS!**
- **Be on site with all documentation (manual, program form, etc.)**
- **Check all wiring connections.**
- **Determine that the power supply and/or backup battery are supplying proper voltages.**
- **Verify your programming information where applicable.**
- **Note the proper model number of this product, and the version level (if known) along with any documentation that came with the product.**
- **Note your ADEMCO customer number and/or company name.**

**Having this information handy will make it easier for us to serve you quickly and effectively.**

You may contact Technical Support via Toll-Free FAX. Please include your return FAX number. You will receive a reply within 24 hours. You may also contact Technical Support via modem to ATLIS-BBS, Technical Support's Electronic Bulletin Board System. Replies are posted within 24 hours.

East Coast Technical Support: 1-800-645-7492 (8 a.m.-6 p.m. E.S.T.)

West Coast Technical Support: 1-800-458-9469 (8 a.m.-5 p.m. P.S.T.)

Technical Support FAX Number: 1-800-447-5086

ATLIS-BBS Electronic Bulletin Board System: 1-516-496-3980

(1200 - 9600 Baud, 8 Data Bits, 1 Start/Stop Bit, No Parity)

ATLIS FAX - Automated Fax Retrieval System: 1-800-573-0153

1-516-921-6704/Ext. 1667

ADEMCO World Wide Web Page - [HTTP://WWW.ADEMCO.COM](http://WWW.ADEMCO.COM)

Internet E-Mail Address - [Ademco\\_Tech\\_SPRT@Ademco-165.Ademco.com](mailto:Ademco_Tech_SPRT@Ademco-165.Ademco.com)

# Section 18. SPECIFICATIONS & ACCESSORIES

## Specifications -----

**CONTROL**    **1. Physical:**    12-1/2" W x 14-1/2" H x 3" D (318mm x 368mm x 76mm)

**2. Electrical:**

VOLTAGE INPUT: from built-in transformer supplying 18VAC at 40VA to 5110XM. Transformer requires nominal 120VAC, 600mA input.

RECHARGEABLE BACK-UP BATTERY: 12VDC, 7AH min., 14AH, max. (Gel type).

Charging Voltage: 13.7VDC, nominal

BELL OUTPUT: 12VDC, 1.0A output. Selectable for style Y EOLR supervision (using 610-7 EOLR) or no supervision.

AUXILIARY POWER OUTPUT: 12VDC, 350mA max.

AUXILIARY RELAY OUTPUT: Selectable for wet form C output rated at 12VDC, 350mA standby max/1A alarm max or dry form C output with contacts rated at 30VAC/VDC, 2A max, resistive loads.

TOTAL OUTPUT POWER: combined aux power and aux relay power standby currents cannot exceed 350mA. Combined aux power, aux relay power and bell alarm currents cannot exceed 1A.

STANDBY TIME: (see Table in Final Powerup section)

FUSING: PTC circuit protectors on battery input and on aux. power, aux. relay, and bell outputs.

**3. Communication:**

FORMATS SUPPORTED:

**Ademco 4+2 Express** (DTMF, 10 characters per second)

**Ademco Contact ID Reporting** (DTMF, 10 characters per second)

**Ademco Low Speed** 3+1, 4+1, 4+2 (10 pulses per second)

**Radionics/SESCO**A 3+1, 4+1, 4+2 (20 pulses per second)

Line Seize: Double Pole

TLM Threshold: Good line when Tip-Ring voltage exceeds 2V; Bad line when less than 2V

Ringer Equivalence: 0.7B

FCC Registration No.: AC398U-68192-AI-E

**4. Maximum Zone Resistance:**

Zones 1-4 = 300 ohms excluding EOLR ;Zone 5 = 100 ohms excluding EOLR

**5. Built-in Indicators:**

Seven LEDs: AC Power, Comm Fail, Line Fault, Silence Audible, Main Dialer Line Seize, Backup Dialer Line Seize

Warning Buzzer: Piezo-electric buzzer sounds for Alarm, Trouble and Supervisory conditions. Silenced by pressing the Silence/Reset button (or by code+off on keypad, if used).

**6. Remote Keypads:**

Supports up to four 6137(gray)/6137R(red) fixed word and 6139(gray)/6137R(red) alpha keypads depending on system usage and current loading. When used as a slave DACT, keypads are optional, but may be used for supplemental DACT status annunciation. When used as a stand-alone control, one keypad, mounted within 3 feet of the control, with the wiring run in conduit, must be used .

**AGENCY LISTINGS****Fire:**

- UL864-NFPA 72 Central Station and Remote Station DACT and local, central station and remote station control.
- FM pending
- CSFM pending

## Accessories (Compatible Devices) -----

### Sounders

<b>System Sensor PA400B (beige)/PA400R (red)</b>	Indoor piezo sounder (red or beige), rated at 90 dB @ 10 feet.
<b>System Sensor MA-12/24</b>	Horn
<b>System Sensor SS1215 ADA</b>	Strobe
<b>System Sensor SS121575 ADA</b>	Strobe
<b>System Sensor SS-12</b>	Strobe
<b>System Sensor MA/SS-12</b>	Horn/Strobe
<b>System Sensor MASS1215 ADA</b>	Horn/Strobe
<b>System Sensor MASS121575 ADA</b>	Horn/Strobe
<b>Wheelock LS1-12-VFR</b>	Strobe
<b>Wheelock MS1-12-VFR</b>	Strobe
<b>Wheelock MT-12-LS-VFR</b>	Horn/Strobe
<b>Wheelock MT4-12-LS-VFR</b>	Horn/Strobe
<b>Wheelock MT-12-MS-VFR</b>	Horn/Strobe
<b>Wheelock MT4-12-MS-VFR</b>	Horn/Strobe
<b>Gentex GXS-2-15</b>	Strobe
<b>Gentex GXS-2-1575</b>	Strobe
<b>Gentex SHG-12-15</b>	Horn/Strobe
<b>Gentex SHG-12-1575</b>	Horn/Strobe
<b>Faraday 5336L-U-14-12-DC</b>	Horn/Strobe
<b>Faraday 5337L-U-14-12-DC</b>	Horn/Strobe

### *System Sensor*

#### **Compatible 2-Wire Smoke Detectors**

<b>1100</b>	Ionization, direct wire
<b>1151</b>	Ionization with B110LP base
<b>1400</b>	Ionization, direct wire
<b>1451</b>	Ionization w/B401B base
<b>1451DH</b>	Ionization duct detect. w/DH400 base
<b>2100</b>	Photoelectric, direct wire
<b>2100T</b>	Photoelectric w/heat sensor, direct wire
<b>2151</b>	Photoelectric with B110LP base
<b>2300T</b>	Photoelectric w/heat sensor, direct wire
<b>2400</b>	Photoelectric, direct wire
<b>2400TH</b>	Photoelectric w/heat sensor, direct wire
<b>2451</b>	Photoelectric w/B401B base
<b>2451TH</b>	Photoelectric w/heat sensor & B401Bbase
<b>2451</b>	Photoelectric duct detector w/DH400 base

#### **Compatible 4-Wire Smoke/Combustion Detectors**

### *System Sensor*

<b>1412</b>	4-wire ionization products of combustion detector
<b>2412</b>	4-wire photoelectric smoke detector
<b>2412TH</b>	4-wire photoelectric smoke detector w/135° F (57° C) heat detector
<b>A77-716B</b>	EOL relay module (supervisory module for wired 4-wire fire zone).
<b>2112/24T</b>	Low-profile 4-wire photoelectric smoke detector w/135° F (57° C) heat detector

## REGULATORY AGENCY STATEMENTS

The 5110XM may be used as a slave DACT providing central or remote station service for a central or remote station listed local FACP. The 5110XM may also be used as a stand-alone local, central station or remote station control. Some comments that apply to these installations are listed below:

When used as a slave DACT:

- \* Wire the 5110XM's hard-wired zones to the FACP alarm, supervisory and trouble contacts. Each zone must have a 2k EOLR installed at the FACP. Program these zones for fire alarm (type 9), fire supervisory (type 18) or trouble (type 19) response, respectively, as required.
- \* Both dialers must be used. Connect both dialers to separate telephone lines and enable supervision for each dialer.
- \* Program the 5110XM to send fire alarm, supervisory(if used), trouble, AC loss, low battery, normal dialer test and off-normal dialer test reports. Program dialer test reports to be sent every 24 hours.
- \* Size the back up battery to provide 24 hour standby time for central station installation and 60 hour standby time for remote station installations.

When used as a stand-alone control:

- \* wire fire alarm and sprinkler supervisory sensors to the 5110XM's hard wired zones. Each zone must have a 2K EOLR installed at the last device on the zone wire run. Program these zones for the required response.
- \* Mount one keypad within 3 feet of the control and run wires to the control in conduit.
- \* For local installations, wire polarized indicating devices to the bell output and enable the bell supervision.
- \* For central and remote station installations, both dialers must be used. Connect both dialers to separate telephone lines and enable supervision for each dialer.
- \* Program the 5110XM to send fire alarm, supervisory (if used), trouble, AC loss, low battery, normal dialer test and off-normal dialer test reports. Program dialer test reports to be sent every 24 hours.
- \* Size the back-up battery to provide 24 hour standby time for local and central station installations and 60 hour standby time for remote station installations.

### **OFEDERAL COMMUNICATIONS COMMISSION (FCC) Part 15 STATEMENT**

This equipment has been tested to FCC requirements and has been found acceptable for use. The FCC requires the following statement for your information:

This equipment generates and uses radio frequency energy and if not installed and used properly, that is, in strict accordance with the manufacturer's instructions, may cause interference to radio and television reception. It has been type tested and found to comply with the limits for a Class B computing device in accordance with the specifications in Part 15 of FCC Rules, which are designed to provide reasonable protection against such interference in a residential installation. However, there is no guarantee that interference will not occur in a particular installation. If this equipment does cause interference to radio or television reception, which can be determined by turning the equipment off and on, the user is encouraged to try to correct the interference by one or more of the following measures:

- If using an indoor antenna, have a quality outdoor antenna installed.
- Reorient the receiving antenna until interference is reduced or eliminated.
- Move the radio or television receiver away from the receiver/control.
- Move the antenna leads away from any wire runs to the receiver/control.
- Plug the receiver/control into a different outlet so that it and the radio or television receiver are on different branch circuits.

If necessary, the user should consult the dealer or an experienced radio/television technician for additional suggestions. The user or installer may find the following booklet prepared by the Federal Communications Commission helpful: "Interference Handbook"

This booklet is available from the U.S.. Government Printing Office, Washington, DC 20402.

*The user shall not make any changes or modifications to the equipment unless authorized by the Installation Instructions or User's Manual. Unauthorized changes or modifications could void the user's authority to operate the equipment.*

**FEDERAL COMMUNICATIONS COMMISSION (FCC) Part 68 STATEMENT**

This equipment complies with Part 68 of the FCC rules. On the front cover of this equipment is a label that contains, among other information, the FCC registration number and ringer equivalence number (REN) for this equipment. If requested, this information must be provided to the telephone company.

This equipment uses the following jacks: An RJ31X is used to connect this equipment to the telephone network.

The REN is used to determine the quantity of devices which may be connected to the telephone line. Excessive RENs on the telephone line may result in the devices not ringing in response to an incoming call. In most, but not all areas, the sum of the RENs should not exceed five (5.0). To be certain of the number of devices that may be connected to the line, as determined by the total RENs, contact the telephone company to determine the maximum REN for the calling area.

If this equipment causes harm to the telephone network, the telephone company will notify you in advance that temporary discontinuance of service may be required. If advance notice is not practical, the telephone company will notify the customer as soon as possible. Also, you will be advised of your right to file a complaint with the FCC if you believe necessary.

The telephone company may make changes in its facilities, equipment, operations, or procedures that could affect the operation of the equipment. If this happens, the telephone company will provide advance notice in order for you to make the necessary modifications in order to maintain uninterrupted service.

If trouble is experienced with this equipment, please contact the manufacturer for repair and warranty information. If the trouble is causing harm to the telephone network, the telephone company may request you remove the equipment from the network until the problem is resolved.

There are no user serviceable components in this product, and all necessary repairs must be made by the manufacturer. Other repair methods may invalidate the FCC registration on this product.

This equipment cannot be used on telephone company-provided coin service. Connection to Party Line Service is subject to state tariffs.

This equipment is hearing-aid compatible.

When programming or making test calls to an emergency number, briefly explain to the dispatcher the reason for the call. Perform such activities in the off-peak hours; such as early morning or late evening.

## **WARNING**

### **THE LIMITATIONS OF THIS ALARM SYSTEM**

While this System is an advanced design security system, it does not offer guaranteed protection against burglary, fire or other emergency. Any alarm system, whether commercial or residential, is subject to compromise or failure to warn for a variety of reasons. For example:

- Intrusion detectors (e.g., passive infrared detectors), smoke detectors, and many other sensing devices will not work without power. Battery-operated devices will not work without batteries, with dead batteries, or if the batteries are not put in properly. Devices powered solely by AC will not work if their AC power supply is cut off for any reason, however briefly.
- Signals sent by wireless transmitters may be blocked or reflected by metal before they reach the alarm receiver. Even if the signal path has been recently checked during a weekly test, blockage can occur if a metal object is moved into the path.
- A user may not be able to reach a panic or emergency button quickly enough.
- While smoke detectors have played a key role in reducing residential fire deaths in the United States, they may not activate or provide early warning for a variety of reasons in as many as 35% of all fires, according to data published by the Federal Emergency Management Agency. Some of the reasons smoke detectors used in conjunction with this System may not work are as follows. Smoke detectors may have been improperly installed and positioned. Smoke detectors may not sense fires that start where smoke cannot reach the detectors, such as in chimneys, in walls, or roofs, or on the other side of closed doors. Smoke detectors also may not sense a fire on another level of a residence or building. A second floor detector, for example, may not sense a first floor or basement fire. Finally, smoke detectors have sensing limitations. No smoke detector can sense every kind of fire every time. In general, detectors may not always warn about fires caused by carelessness and safety hazards like smoking in bed, violent explosions, escaping gas, improper storage of flammable materials, overloaded electrical circuits, children playing with matches, or arson. Depending on the nature of the fire and/or location of the smoke detectors, the detector, even if it operates as anticipated, may not provide sufficient warning to allow all occupants to escape in time to prevent injury or death.
- Passive Infrared Motion Detectors can only detect intrusion within the designed ranges as diagrammed in their installation manual. Passive Infrared Detectors do not provide volumetric area protection. They do create multiple beams of protection, and intrusion can only be detected in unobstructed areas covered by those beams. They cannot detect motion or intrusion that takes place behind walls, ceilings, floors, closed doors, glass partitions, glass doors, or windows. Mechanical tampering, masking, painting or spraying of any material on the mirrors, windows or any part of the optical system can reduce their detection ability. Passive Infrared Detectors sense changes in temperature; however, as the ambient temperature of the protected area approaches the temperature range of 90° to 105°F (32° to 40°C), the detection performance can decrease.
- Alarm warning devices such as sirens, bells or horns may not alert people or wake up sleepers if they are located on the other side of closed or partly open doors. If warning devices are located on a different level of the residence from the bedrooms, then they are less likely to waken or alert people inside the bedrooms. Even persons who are awake may not hear the warning if the alarm is muffled by noise from a stereo, radio, air conditioner or other appliance, or by passing traffic. Finally, alarm warning devices, however loud, may not warn hearing-impaired people.
- Telephone lines needed to transmit alarm signals from a premises to a central monitoring station may be out of service or temporarily out of service. Telephone lines are also subject to compromise by sophisticated intruders.
- Even if the system responds to the emergency as intended, however, occupants may have insufficient time to protect themselves from the emergency situation. In the case of a monitored alarm system, authorities may not respond appropriately.
- This equipment, like other electrical devices, is subject to component failure. Even though this equipment is designed to last as long as 20 years, the electronic components could fail at any time.

The most common cause of an alarm system not functioning when an intrusion or fire occurs is inadequate maintenance. This alarm system should be tested weekly to make sure all sensors and transmitters are working properly. The security keypad (and remote keypad) should be tested as well.

Wireless transmitters (used in some systems) are designed to provide long battery life under normal operating conditions. Longevity of batteries may be as much as 4 to 7 years, depending on the environment, usage, and the specific wireless device being used. External factors such as humidity, high or low temperatures, as well as large swings in temperature, may all reduce the actual battery life in a given installation. This wireless system, however, can identify a true low battery situation, thus allowing time to arrange a change of battery to maintain protection for that given point within the system.

Installing an alarm system may make the owner eligible for a lower insurance rate, but an alarm system is not a substitute for insurance. Homeowners, property owners and renters should continue to act prudently in protecting themselves and continue to insure their lives and property.

We continue to develop new and improved protection devices. Users of alarm systems owe it to themselves and their loved ones to learn about these developments.

## **ADEMCO LIMITED WARRANTY**

Alarm Device Manufacturing Company, a Division of Pittway Corporation, and its divisions, subsidiaries and affiliates ("Seller"), 165 Eileen Way, Syosset, New York 11791, warrants its products to be in conformance with its own plans and specifications and to be free from defects in materials and workmanship under normal use and service for 24 months from the date stamp control on the product or, for products not having an Ademco date stamp, for 12 months from date of original purchase unless the installation instructions or catalog sets forth a shorter period, in which case the shorter period shall apply. Seller's obligation shall be limited to repairing or replacing, at its option, free of charge for materials or labor, any product which is proved not in compliance with Seller's specifications or proves defective in materials or workmanship under normal use and service. Seller shall have no obligation under this Limited Warranty or otherwise if the product is altered or improperly repaired or serviced by anyone other than Ademco factory service. For warranty service, return product transportation prepaid, to Ademco Factory Service, 165 Eileen Way, Syosset, New York 11791.

THERE ARE NO WARRANTIES, EXPRESS OR IMPLIED, OF MERCHANTABILITY, OR FITNESS FOR A PARTICULAR PURPOSE OR OTHERWISE, WHICH EXTEND BEYOND THE DESCRIPTION ON THE FACE HEREOF. IN NO CASE SHALL SELLER BE LIABLE TO ANYONE FOR ANY CONSEQUENTIAL OR INCIDENTAL DAMAGES FOR BREACH OF THIS OR ANY OTHER WARRANTY, EXPRESS OR IMPLIED, OR UPON ANY OTHER BASIS OF LIABILITY WHATSOEVER, EVEN IF THE LOSS OR DAMAGE IS CAUSED BY THE SELLER'S OWN NEGLIGENCE OR FAULT.

Seller does not represent that the products it sells may not be compromised or circumvented; that the products will prevent any personal injury or property loss by burglary, robbery, fire or otherwise; or that the products will in all cases provide adequate warning or protection. Customer understands that a properly installed and maintained alarm may only reduce the risk of a burglary, robbery, fire or other events occurring without providing an alarm, but it is not insurance or a guarantee that such will not occur or that there will be no personal injury or property loss as a result. CONSEQUENTLY, SELLER SHALL HAVE NO LIABILITY FOR ANY PERSONAL INJURY, PROPERTY DAMAGE OR OTHER LOSS BASED ON A CLAIM THE PRODUCT FAILED TO GIVE WARNING. HOWEVER, IF SELLER IS HELD LIABLE, WHETHER DIRECTLY OR INDIRECTLY, FOR ANY LOSS OR DAMAGE ARISING UNDER THIS LIMITED WARRANTY OR OTHERWISE, REGARDLESS OF CAUSE OR ORIGIN, SELLER'S MAXIMUM LIABILITY SHALL NOT IN ANY CASE EXCEED THE PURCHASE PRICE OF THE PRODUCT, WHICH SHALL BE THE COMPLETE AND EXCLUSIVE REMEDY AGAINST SELLER. This warranty replaces any previous warranties and is the only warranty made by Seller on this product. No increase or alteration, written or verbal, of the obligations of this Limited Warranty is authorized.

# INDEX

1100, 19, 66  
1400, 19, 66  
1412, 19, 66  
1451, 19, 66  
1451DH, 19, 66  
2100, 19, 66  
2100T 19, 66  
2112/24T, 19, 66  
24-hour Audible Alarm, 47  
24-hour Silent Alarm, 47  
24-Hr. Trouble, 48  
2400, 66  
2400TH, 66  
2412, 18, 66  
2412TH, 18, 66  
2451, 66  
2451TH, 66  
3+1 and 4+1 Expanded Formats, 41  
3+1 and 4+1 Standard Formats, 41  
3+1 or 4+1 Standard Format, 44, 53  
3-digit number, 34, 35  
4+2 Format, 41  
4-Wire Smoke Detector Reset, 28  
6137, 14  
6137, 6137R, 6,13  
6137R, 14  
6139, 6, 13, 14, 15, 20, 25  
6139R, 6, 14

## -A-

A77-716B, 66  
"AC LOSS", 61  
AC LOSS REPORT CODE, 45,53  
AC Power Connections, 29  
AC Power Input, 7  
AC RESTORE REPORT CODE, 45, 54  
AC Transformer, 12  
Accessories, 66  
addressable type keypads, 14  
Ademco 4+2 Express, 64  
Ademco Contact ID, 7, 41  
Ademco Express, 7  
Ademco Low Speed, 7  
Agency Listings, 8, 65  
Alarm Bell Sound, 25  
ALARM BELL TIMEOUT, 49  
Alarm Bell Timeout, 25  
ALARM INDICATING DEVICES, 24  
ALARM RESTORE REPORT CODE, 45, 54  
"Alarm Silenced" message, 19  
Alpha, 16  
Alpha descriptor, 36  
ALPHA DESCRIPTOR PROGRAMMING, 34  
Alpha Keypad, 6, 13,16  
Alpha Vocabulary List, 35  
answering machine., 46, 55  
Assigning Zone Descriptors, 34  
Auxiliary Power Output, 7

Auxiliary Relay, 7  
AUXILIARY RELAY CONNECTIONS, 27  
Auxiliary Relay Disable, 23  
AUXILIARY RELAY TIMEOUT, 50

## -B-

Back-Up Battery, 8,12  
Back-up Dialer Supervision, 23  
Backup Dialer, 6  
Basic Hardwired, 6  
BASIC HARD-WIRED ZONES 1-5, 17  
"BAT", 61  
battery connector, 33  
Battery Saver Option, 28  
Battery Supervision, 33  
Bell Output, 6  
Bell Supervision, 23  
bells, 24  
Built-in Indicators and Switches, 7  
Busy-Standby, 30, 61  
BYPASS REPORT CODE, 45, 53  
BYPASS RESTORE REPORT CODE, 45, 54  
Bypassing Zones, 59

## -C-

cabinet lock, 9  
Calculating the Battery Size, 30  
central station, 53  
Central Station Initiated, 57  
CHARACTER (ASCII) CHART, 39  
CHARACTER CHART, 34  
CHARACTER LIST, 37  
Charging Voltage, 64  
"CHECK", 61  
check 11, 61  
check 12 back-up dialer, 61  
Check-Out Procedure For Detection Zones, 21  
Circuit Board, 10  
circuit breaker protection, 29  
Comm Fail, 40  
Comm. Failure (FC), 61  
Communication, 64  
Communication Formats Supported, 7  
Compatible 2-Wire Smoke Detectors, 19  
Compatible 4-Wire Smoke/Combustion Detectors, 66  
compatible alarm indicating devices, 24  
Compatible UL Listed Indicating Devices, 24  
Connecting The Back-Up Battery, 30  
Contact ID, 42, 44, 53  
CONTACT ID EVENT CODES, 42  
Contact ID Reporting, 64  
control cabinet, 9  
Custom Alpha Editing, 52, 54  
Custom Words, 37, 39

## -D-

DACT, 6  
DACT Wire Run Length Chart, 13  
Data Encryption, 56  
DATA FIELD DESCRIPTIONS, 49

Default Descriptor , 35  
DEFAULT VALUES, 55  
Description of System Data Fields, 49  
Dialer Operation, 11  
DIALER PROGRAMMING, 50  
Dialer Test, 61  
DOWNLOAD INFORMATION, 55  
DOWNLOAD PHONE NUMBER , 45,55  
Downloading, 46, 55

-E-

Earth Ground, 12, 29  
Earth Ground Supervision, 23  
EEROM, 7  
Emergency Keys, 59  
Entering Program Mode, 15  
Entering Zone Descriptors, 34  
EOLR, 6, 14, 18, 22  
Erasing an Entry in a Data Field, 16  
Exiting the Programming Mode, 16, 55  
Expanded or 4+2 Format, 44, 53  
external sounder options, 24

-F-

FACP, 6  
Factory Defaults, 16  
FCC, 67, 68  
FINAL POWER UP, 29  
Fire Alarm, 47  
Fire alarm sounding, 19  
Fire Alarm Verification for Smoke Detectors, 19  
FIRE DRILL TEST, 26  
Fire Sprinkler Supervisory, 48  
FIRE WALK TEST, 60  
Fire Waterflow Alarm, 48  
Fixed-Word Keypads, 6  
Form C, 7  
formats, 40  
FUSING, 64

-G-

GROUP RESTORES FOR TROUBLE and  
BYPASS, 45, 54

-H-

handshake, 40  
hardwired, 6  
Hayes modem, 7, 15, 56

-I-

IBM (or compatible) personal computer, 15, 56  
Initial Download, 56  
INSTALLING REMOTE KEYPADS, 13  
INSTALLING THE CONTROL, 9  
Interactive Mode Programming (\*56 and \*82),  
16,20

-K-

keypad, 6  
Keypad Connections, 14  
Keypad Emergency Keys, 6, 23  
Keypad Functions , 59  
keypads, 13

kissoff, 40

-L-

LED indicators, 7  
Lock, 9  
LOW BAT REPORT CODE, 45, 53  
LOW BAT RESTORE REPORT CODE, 45, 54  
Low Battery message, 62  
LRR communication failure, 61

-M-

MAIN DIALER PULSE/TONE , 43, 50  
Main Dialer Supervision, 23  
main PC board, 9  
Making the Battery Connections, 32  
Master Code, 9, 49, 58  
MECHANICS OF PROGRAMMING, 15  
MISCELLANEOUS OPTIONS, 54  
Modem Comm, 61  
monitored telephone line, 61  
Mounting the Cabinet, 9  
Mounting the Keypads, 14

-N-

"NO AC", 61  
NORMAL TEST REPORT CODE, 45, 53  
NOT READY, 30

-O-

OC, 14  
ONE MAN FIRE WALK TEST, 60  
Open Circuit (OC), 14, 61  
Optima 24 Plus FAX96 Modem, 56  
OUTPUT TO LONG RANGE RADIO, 49

-P-

PA400R, 24, 66  
PABX ACCESS CODE, 11, 43, 50  
PERIODIC TEST REPORT, 44, 51  
Phone Line, 11  
Power Failure, 61  
Powering Up the System, 30  
Preliminary Check-out Procedure, 14  
PRIMARY PHONE No., 43, 50  
Programming, 7,15  
Programming Communication Options , 43  
Programming for External Sounders, 25  
Programming the Auxiliary Relay, 28  
Programming the Descriptors, 34

-R-

Radionics/SESCO, 64  
REGULATORY AGENCY STATEMENTS, 67  
Relay Connections, 27  
REMOTE PROGRAMMING, 56, 57  
Report Code Formats, 40  
Resetting Smokes, 59  
RESTORE, 54  
Reviewing a Data Field, 16  
RING DETECTION, 46, 55

-S-

SECONDARY PHONE No., 43, 50  
Security Code Handshake, 56

SESCOA/RADIONICS SELECT, 44, 51  
 Silence/Reset key, 19, 22  
 Silencing Sounders, 59  
 sirens, 24  
 Site Initiated Remote Programming, 56  
 slave DACT, 6  
 SMARTMODEM 1200, 56  
 smoke detectors, 6  
 Sounder Connections , 25  
 Sounders, 66  
 SPECIFICATIONS & ACCESSORIES, 64  
 SPLIT/DUAL REPORTING, 44, 51  
 Station Initiated Remote Programming, 56  
 SUBSCRIBER ACCOUNT. No., 43, 50  
 SUPERVISORY REPORT CODE, 53  
 SUPERVISORY RESTORE REPORT CODE, 53  
 System Commands, 59  
 SYSTEM COMMUNICATION, 40  
 SYSTEM LO BAT, 61  
 SYSTEM NORMAL, 30  
 SYSTEM OPERATION, 58  
 SYSTEM STATUS REPORT CODES, 44, 53  
 System Zone Assignments, 23

-T-

TECHNICAL SUPPORT, 63  
 Telephone Line Failure, 61  
 Telephone Line Supervision, 11  
 Test Procedure , 60  
 Testing the Sounder, 26  
 TESTING THE SYSTEM, 60  
 TOTAL STANDBY/ALARM LOAD  
 WORKSHEETS, 31  
 transformer, 7  
 Trim Ring Kit, 14  
 Trouble Conditions, 61  
 TROUBLE REPORT CODE, 45, 53  
 TROUBLE RESTORE REPORT CODE, 45, 54  
 Trouble/Supervisory Activation, 28  
 TROUBLESHOOTING GUIDE, 62  
 Turning Off Fire Alarm Sounding, 19

-U-

UL, 6  
 Un-bypassing Zones, 59  
 User Codes, 58

-V-

V-Link, 7, 56, 57  
 verification, 20  
 VOCABULARY LIST, 38

-W-

warning buzzer, 7  
 water flow, 6  
 WATERFLOW ALARM SILENCING , 54  
 Wiring Devices To Zones 1-5, 17  
 Wiring 2-Wire Smoke Detector, 18

-Z-

ZONE ASSIGNMENT/ALARM REPORT CODES,  
 51  
 ZONE ASSIGNMENTS/ALARM REPORT CODES,  
 44  
 Zone Descriptors 38  
 Zone Not Used, 47  
 Zone Number (Zn), 51  
 Zone Programming, 16  
 ZONE RESPONSE TYPE DEFINITIONS, 47  
 Zone Response Types, 47  
 Zone Type (ZT), 20, 52  
 Zone Type 18 Delay Enable, 53  
 Zone Type Default, 52  
 Zone Type 00, 47  
 Zone Type 06, 47  
 Zone Type 07, 47  
 Zone Type 08, 47  
 Zone Type 09, 47  
 Zone Type 16, 47  
 Zone Type 17, 48  
 Zone Type 18, 48  
 Zone Type 19, 48  
 Zones 1-7 Bell / Aux. Relay Activation), 25

# NOTES

# 5110XM SUMMARY OF CONNECTIONS

## WARNING:

OWNER'S INSTRUCTION NOTICE NOT TO BE REMOVED  
Refer to the 5110XM Installation Instructions N8026  
for additional information

MAY BE USED AS A SLAVE DACT PROVIDING CENTRAL OR REMOTE STATION SERVICE FOR A CENTRAL OR REMOTE STATION UL LISTED FACP. MAY ALSO BE USED AS A STAND-ALONE NON-CODED LOCAL, CENTRAL STATION AND REMOTE STATION PROTECTED PREMISES UNIT PROVIDING MANUAL FIRE ALARM, AUTOMATIC FIRE ALARM, SPRINKLER SUPERVISORY AND WATER FLOW ALARM. INSTALLATION LIMITS UNDER JURISDICTION OF LOCAL AUTHORITY.

THIS EQUIPMENT SHOULD BE INSTALLED IN ACCORDANCE WITH THE NATIONAL FIRE PROTECTION ASSOCIATION'S STANDARD 72 (NATIONAL FIRE PROTECTION ASSOC., BATTERY MARCH PARK, QUINCY, MA 02269). PRINTED INFORMATION DESCRIBING PROPER INSTALLATION, OPERATION, TESTING, MAINTENANCE, AND REPAIR SERVICE IS PROVIDED WITH THIS EQUIPMENT.

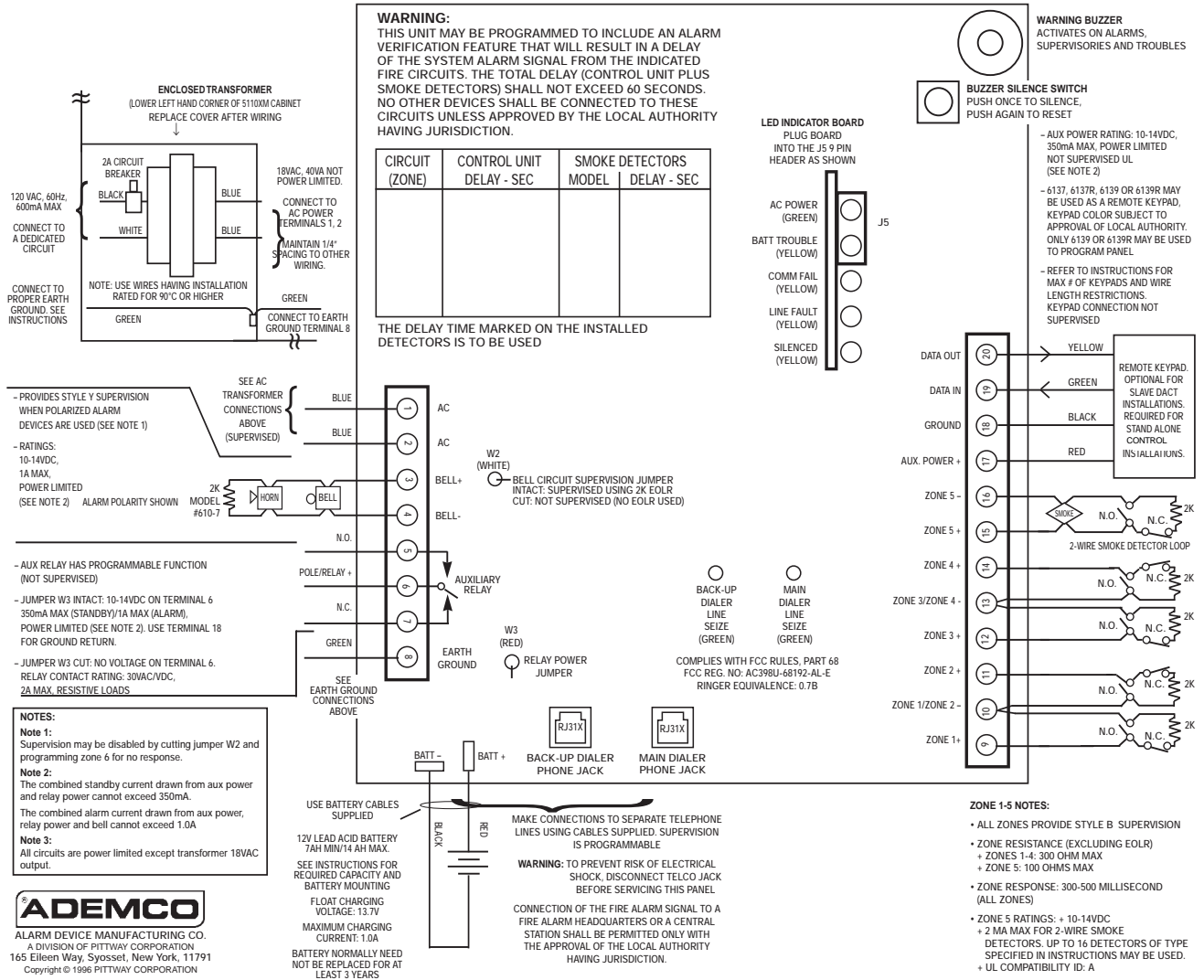

N8027 4/96

## Ademco 5110XM SUMMARY OF CONNECTIONS

**ALARM DEVICE MANUFACTURING CO.**  
A DIVISION OF PITTMAN CORPORATION  
**165 Eileen Way, Syosset, New York 11791**  
Copyright © 1995 PITTMAN CORPORATION