



No. 4204 RELAY MODULE

For Use With Control/Communicators Supporting
Relay Module Connection Via Keypad Lines

INSTALLATION INSTRUCTIONS

GENERAL INFORMATION

The 4204 Relay Module adds from one to four dry, form C (SPDT) relay outputs to compatible control/communicators. It interfaces to the control's keypad wiring.

The 4204 can be mounted inside the control's cabinet or mounted remotely.

If mounted remotely, the 4204 has two forms of protection. First, the 4204 has a built-in tamper switch which allows it to detect and report the removal of its cover to the control. Second, communication to the 4204 is supervised so that it cannot be disconnected from the keypad wiring without detection by the control. If the wiring is cut, a tamper or alarm signal will result, to indicate that this device (and possibly other devices connected to the keypad wiring) has become inoperative.

INSTALLATION

For UL Installations:

When used with controls which do not support cover tamper or supervise communications wiring to the 4204, mount the 4204 inside the control's cabinet.

When used with controls which support cover tamper and supervise communications wiring to the 4204, the 4204 may either be mounted inside the control's cabinet or mounted remotely.

When mounted inside the control's cabinet, some controls allow the 4204 to be mounted horizontally as follows: insert the self-tapping screws (provided) in two adjacent raised tabs on the back of the cabinet. Leave the heads projecting 1/8". Hang the 4204 on the screw heads via two of the slotted holes on the back of its housing. The 4204's cover need not, in this case, be tamper-protected. If the DIP switch is set with its position 1 "ON" (see the table below), the cover can be left off. See the control's instructions for additional information.

When the 4204 is mounted remotely, holes on its back permit it to be mounted horizontally or vertically. Wires can exit from the side or via the breakout on the back of its housing. The DIP switch must be set with its position 1 "OFF" and when the installation is completed, the unit's tamper-protected cover must be replaced.

Affix the connections label that accompanies the 4204 to the inside of the 4204's cover (if the cover is used) or to the inside of the control's cover.

CONNECTIONS AND SETTINGS

Select and set an address for the 4204, using its DIP switch as shown in the table below. Each 4204 used with the control must be assigned a unique address so the control can identify the 4204 and communicate with it properly. The address to be set is determined by the particular control to be used, and the control's installation instructions must be consulted. As shipped, the DIP switch is set for an address of "0".

Connections to the 4204's four relays are made via 12-position terminal block TB2. Refer to the control's installation instructions for specific information on how to program the control's various activation options for the relays.

Connections to the control's keypad wiring points can be made via 4-position terminal block TB1, the 4-pin plug, or both (wire color connections are the same). See the diagram on the other side of this page.

SPECIFICATIONS

Physical 6-7/16" W x 4-1/4" H x 1-1/4" D
(163mm x 108mm x 32mm)

Electrical

Input Voltage: 12VDC nominal (10–14VDC), from control's remote keypad connection points

Input Current: 15mA standby + 40mA per active relay

Contact Rating: 2A max. at 28VDC/AC (resistive loads)

DIP SWITCH SETTINGS

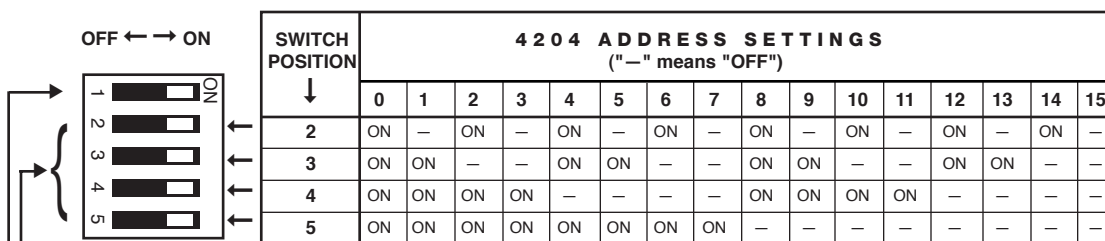

DIP SWITCH: (WHITE AREAS DENOTE SWITCH HANDLES)

POSITIONS 2–5: DETERMINE 4204's ADDRESS.
CONSULT CONTROL'S INSTRUCTIONS FOR ADDRESS TO USE.
SHOWN SET (AS SHIPPED) FOR ADDRESS = 0.

POSITION 1: DETERMINES COVER TAMPER RESPONSE.
ON = DISABLED (SHOWN, AS SHIPPED)
OFF = ENABLED (COVER IS TAMPER-PROTECTED)

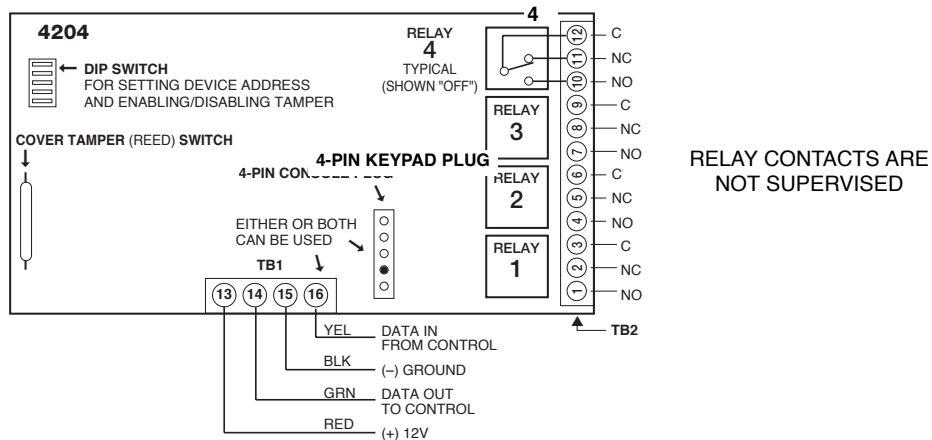

4204 CONNECTIONS

REFER TO THE INSTALLATION INSTRUCTIONS FOR THE CONTROL WITH WHICH THIS DEVICE IS USED FOR DETAILS REGARDING THE LIMITATIONS OF THE ENTIRE ALARM SYSTEM.

ADEMCO LIMITED WARRANTY

Alarm Device Manufacturing Company, a Division of Pittway Corporation, and its divisions, subsidiaries and affiliates ("Seller"), 165 Eileen Way, Syosset, New York 11791, warrants its products to be in conformance with its own plans and specifications and to be free from defects in materials and workmanship under normal use and service for 24 months from the date stamp control on the product or, for products not having an Ademco date stamp, for 12 months from date of original purchase unless the installation instructions or catalog sets forth a shorter period, in which case the shorter period shall apply. Seller's obligation shall be limited to repairing or replacing, at its option, free of charge for materials or labor, any product which is proved not in compliance with Seller's specifications or proves defective in materials or workmanship under normal use and service. Seller shall have no obligation under this Limited Warranty or otherwise if the product is altered or improperly repaired or serviced by anyone other than Ademco factory service. For warranty service, return product transportation prepaid, to:

Ademco Factory Service, 165 Eileen Way, Syosset, New York 11791.

THERE ARE NO WARRANTIES, EXPRESS OR IMPLIED, OF MERCHANTABILITY, OR FITNESS FOR A PARTICULAR PURPOSE OR OTHERWISE, WHICH EXTEND BEYOND THE DESCRIPTION ON THE FACE HEREOF. IN NO CASE SHALL SELLER BE LIABLE TO ANYONE FOR ANY CONSEQUENTIAL OR INCIDENTAL DAMAGES FOR BREACH OF THIS OR ANY OTHER WARRANTY, EXPRESS OR IMPLIED, OR UPON ANY OTHER BASIS OF LIABILITY WHATSOEVER, EVEN IF THE LOSS OR DAMAGE IS CAUSED BY THE SELLER'S OWN NEGLIGENCE OR FAULT.

Seller does not represent that the products it sells may not be compromised or circumvented; that the products will prevent any personal injury or property loss by burglary, robbery, fire or otherwise; or that the products will in all cases provide adequate warning or protection. Customer understands that a properly installed and maintained alarm may only reduce the risk of a burglary, robbery, fire or other events occurring without providing an alarm, but it is not insurance or a guarantee that such will not occur or that there will be no personal injury or property loss as a result. CONSEQUENTLY, SELLER SHALL HAVE NO LIABILITY FOR ANY PERSONAL INJURY, PROPERTY DAMAGE OR OTHER LOSS BASED ON A CLAIM THE PRODUCT FAILED TO GIVE WARNING. However, if Seller is held liable, whether directly or indirectly, for any loss or damage arising under this Limited Warranty or otherwise, regardless of cause or origin, Seller's maximum liability shall not in any case exceed the purchase price of the product, which shall be the complete and exclusive remedy against Seller. This warranty replaces any previous warranties and is the only warranty made by Seller on this product. No increase or alteration, written or verbal, of the obligations of this Limited Warranty is authorized.

ADEMCO GROUP

165 Eileen Way, Syosset, New York 11791

Copyright © 1997 PITTWAY CORPORATION