

ADEMCO**INSTALLATION
INSTRUCTIONS****No. 4197
LINE EXTENDER
MODULE****GENERAL INFORMATION**

The ADEMCO No. 4197 LINE EXTENDER MODULE is a system accessory for the VECTOR SERIES 2000 control panel. When connected, the module doubles the maximum wiring run of the polling loop. The module may be powered from the panel or from an ADEMCO No. 729 POWER SUPPLY with an external 12V, 1.2 AH (or larger capacity) GEL or LEAD ACID TYPE battery.

IMPORTANT

The No. 4197 LINE EXTENDER MODULE is not designed for use with a Class A polling loop.

OPERATION

The No. 4197 LINE EXTENDER MODULE functions as a signal repeater on the polling loop. As polling information is communicated along the polling loop, the module receives and then re-transmits the message. This extra boost of the signal enables the polling loop to be extended.

The module is fully supervised, detecting faults, single or multiple breaks, and shorts in the polling loop. Should the module's operating power cease or go low, the control panel would detect and report an open loop.

INSTALLATION

The following instructions are intended as a guide only. Final approval and acceptance are the jurisdiction of the local authorities. All wiring should be in accordance with national and local codes for burglary system installation.

MOUNTING

The module can be mounted with double-faced adhesive tape.

Make certain the mounting location conforms to the requirements cited in the SPECIFICATIONS section.

WIRING:**TERMINAL****PURPOSE**

1	(+) BATTERY or CONTROL PANEL AUXILIARY CURRENT OUTPUT
2	(-) BATTERY or CONTROL PANEL CIRCUIT GROUND
3	SEE APPROPRIATE DIAGRAM
4	(+) No. 729 POWER SUPPLY (IF USED)
5	(-) No. 729 POWER SUPPLY (IF USED)
6	(+) POLLING LOOP INPUT (FROM PANEL)
7	(-) POLLING LOOP INPUT (FROM PANEL)
8	(-) POLLING LOOP OUTPUT (TO EXTENDED LOOP)
9	(+) POLLING LOOP OUTPUT (TO EXTENDED LOOP)

SPECIFICATIONS

DIMENSIONS:	WIDTH:	3.94" (10 cm)
	LENGTH:	5" (12.7 cm)
	DEPTH:	1.25" (3.2 cm)
WEIGHT:	0.4 lbs.	
OPERATING TEMP:	32°F - 120°F (0°C - 49°C)	
HUMIDITY:	10% - 85% (RH)	
ELECTRICAL RATINGS:	12V.DC @ 80mA	
FUSE:	POLLING LOOP/BATTERY: 2A (ADEMCO No. 90-2)	
EXTENSION LENGTH:	650' (198m)-22 AWG	
	1500' (457m)-18 AWG	
	2400' (732m)-16 AWG	

LIMITED WARRANTY

Seller warrants its products to be in conformance with its own plans and specifications and to be free from defects in materials and workmanship under normal use and service for 18 months from the date stamp control on the product or for products not having an Ademco date stamp, for 12 months from date of original purchase unless the installation instructions or catalog sets forth a shorter period, in which case the shorter period shall apply. Seller's obligation shall be limited to repairing or replacing, at its option, free of charge for materials or labor, any part which is proved not in compliance with Seller's specifications or proves defective in materials or workmanship under normal use and service. This warranty is void if the product is altered or improperly repaired or serviced by anyone other than Ademco factory service. For warranty service, return product transportation prepaid, to Ademco Factory Service, 165 Eileen Way, Syosset, New York 11791.

THERE ARE NO WARRANTIES, EXPRESS OR IMPLIED, OF MERCHANTABILITY, OR FITNESS FOR A PARTICULAR PURPOSE OR OTHERWISE, WHICH EXTEND BEYOND THE DESCRIPTION ON THE FACE HEREOF. In no case shall Seller be liable to anyone for any consequential or incidental damages for breach of this or any other warranty, express or implied, or upon any other basis of liability whatsoever, even if the loss or damage is caused by the Seller's own negligence or fault.

Seller does not represent that its product may not be compromised or circumvented; that the product will prevent any personal injury or property loss by burglary, robbery, fire or otherwise; or that the product will in all cases provide adequate warning or protection. Buyer understands that a properly installed and maintained alarm may only reduce the risk of a burglary, robbery or fire without warning, but it is not insurance or a guarantee that such will not occur or that there will be no personal injury or property loss as a result. CONSEQUENTLY, SELLER SHALL HAVE NO LIABILITY FOR ANY PERSONAL INJURY, PROPERTY DAMAGE OR OTHER LOSS BASED ON A CLAIM THE PRODUCT FAILED TO GIVE WARNING. However, if Seller is held liable, whether directly or indirectly, for any loss or damage arising under this Limited Warranty or otherwise, regardless of cause or origin, Seller's maximum liability shall not in any case exceed the purchase price of the product, which shall be fixed as liquidated damages and not as a penalty, and shall be the complete and exclusive remedy against Seller.

This warranty replaces all previous warranties and is the only warranty made by Ademco on this product. No increase or alteration, written or verbal, of the obligation of this warranty is authorized.

"Ademco" is a registered trademark of Alarm Device Manufacturing Company, Division of Pittway Corp.

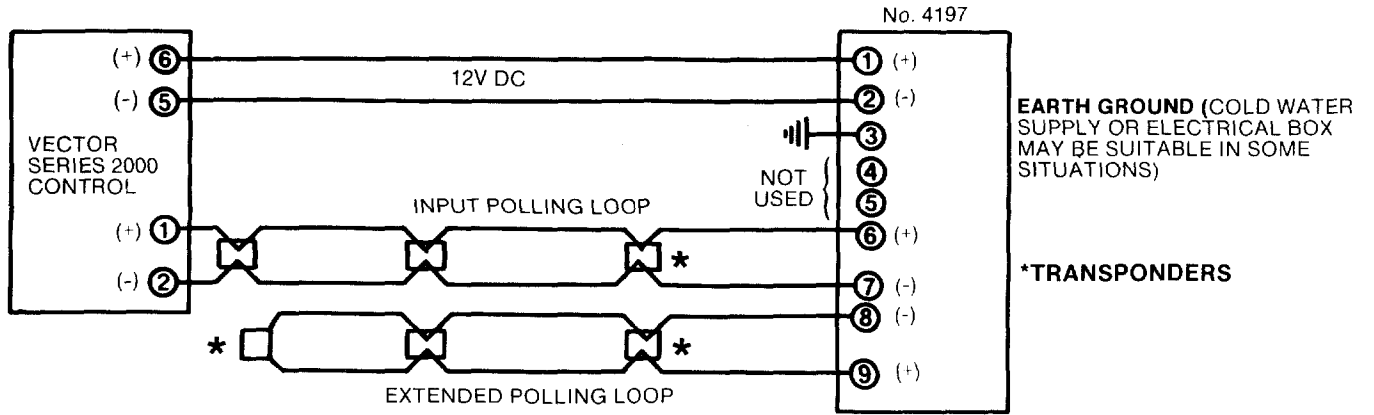

DIAGRAM 1. No. 4197 POWERED FROM PANEL

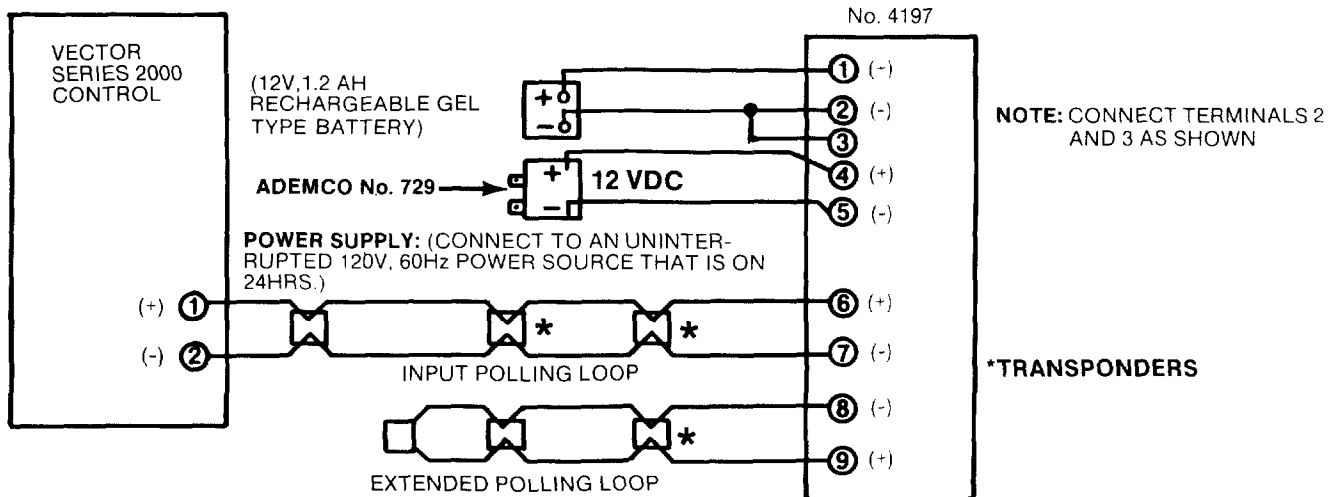

DIAGRAM 2. No. 4197 POWERED FROM POWER SUPPLY AND BATTERY

